

TECHNICAL MANUAL	INTRODUCTION	1-1
UNIT, INTERMEDIATE DIRECT SUPPORT AND INTERMEDIATE GENERAL SUPPORT MAINTENANCE INSTRUCTIONS	UNIT MAINTENANCE INSTRUCTIONS	2-1
ENVIRONMENTAL CONTROL SUBSYSTEM FOR LANDING CRAFT UTILITY (LCU)	INTERMEDIATE DIRECT SUPPORT MAINTENANCE INSTRUCTIONS	3-1
	INTERMEDIATE GENERAL SUPPORT MAINTENANCE INSTRUCTIONS	4-1
NSN 1905-01-154-1191	APPENDIXES	A-1
	ALPHABETICAL INDEX	INDEX-1

DISTRIBUTION STATEMENT A: Approved for public release; distribution is unlimited.

HEADQUARTERS, DEPARTMENT OF THE ARMY

JANUARY 1989

WARNING**MODIFICATION HAZARD**

Unauthorized modifications, alterations or installations of or to this equipment are prohibited and are in violation of AR 750-10. Any such unauthorized modifications, alterations or installations could result in death, injury or damage to the equipment.

HIGH PRESSURE SYSTEM HAZARDS

Pressurized liquid or gas systems can cause serious injuries if high pressure lines or equipment fall.

High pressure compressed air tanks, piping systems and air operated devices possess potential for serious injury to eyes and exposed areas of skin due to escaping air pressure.

MOVING MACHINERY HAZARDS

Be very careful when operating or working near moving machinery. Running engines, rotating fans, shafts, and other moving machinery parts could cause personal injury or death.

ELECTRICAL HAZARDS

Whenever possible, the power supply to the equipment must be shut off before beginning work on the equipment. Do not be misled by the term "low voltage." Potentials as low as 50 volts may cause death under adverse conditions.

Be careful not to contact 115-Vac input connections when installing or operating this equipment.

Whenever the nature of the operation permits, keep one hand away from the equipment to reduce the hazard of current flowing through the body.

Replace or repair components only after the affected circuit has been secured, locked out, and tagged out (FM 4-01.502, Supersedes FM 55-502). Performing replacement with the circuit energized may result in injury or death.

TOXIC HAZARD

TOXIC HAZARD EXISTS. DO NOT use refrigerant (freon) near open flames or electric heating elements. Freon is not flammable and is non-toxic, but exposure of the gas to an open flame or hot metal surface forms a TOXIC PHOSGENE GAS. Provide thorough ventilation whenever used in order to avoid injury to personnel.

TOXIC HAZARD EXISTS. Use of cleaning solvent in a confined area can result in injury or death. Avoid prolonged breathing of fumes and solvent contact with skin or eyes. Avoid use near heat or open flame. Use in well ventilated areas only.

For Artificial Respiration, refer to FM 21-11.

CHANGE

NO. 4

HEADQUARTERS
DEPARTMENT OF THE ARMY
WASHINGTON, D.C., 30 SEPTEMBER 2008

TECHNICAL MANUAL
UNIT, INTERMEDIATE DIRECT SUPPORT AND
INTERMEDIATE GENERAL SUPPORT
MAINTENANCE INSTRUCTIONS

ENVIRONMENTAL CONTROL SUBSYSTEM
FOR
LANDING CRAFT, UTILITY (LCU)
NSN 1905-01-154-1191

Distribution Statement A: Approved for public release; distribution is unlimited.

TM 55-1905-223-24-17, 17 January 1989, is changed as follows:

1. Remove and insert pages as indicated below. New or changed text is indicated by a vertical bar in the margin. An illustration change is indicated by a miniature pointing hand.

Remove pages

None

None

a/(b blank)

None

i through ii

1-1 through 1-2

1-7 through 1-10

2-13 through 2-14

None

B-9 through B-10

Index 1 through Index 2

DA Form 2028

Insert pages

Change Transmittal Sheet

Authentication Page

a/(b blank)

A/(B blank)

i through ii

1-1 through 1-2

1-7 through 1-10

2-13 through 2-14

2-82.1 through 2-82.4

B-9 through B-10

Index 1 through Index 2

DA Form 2028

2. Retain this sheet in front of the manual for reference purposes.

By Order of the Secretary of the Army:

Official:



JOYCE E. MORROW

*Administrative Assistant to the
Secretary of the Army*

0825303

GEORGE W. CASEY, JR.
*General, United States Army
Chief of Staff*

DISTRIBUTION: To be distributed in accordance with the Initial Distribution Number (IDN) 253666 requirements for TM 55-1905-223-24-17.

CHANGE
NO. 3

HEADQUARTERS
DEPARTMENT OF THE ARMY
WASHINGTON, D.C., 30 JUNE 1994

Unit, Intermediate Direct Support and Intermediate General Support
Maintenance Instructions

ENVIRONMENTAL CONTROL SUBSYSTEM
FOR
LANDING CRAFT UTILITY (LCU)
NSN 1905-01-154-1191

DISTRIBUTION STATEMENT A: Approved for public release; distribution is unlimited.

TM 55-1905-223-24-17, 17 January 1989, is changed as follows:

1. Remove and insert pages as indicated below. New or changed text material is indicated by a vertical bar in the margin. An illustration change is indicated by a miniature pointing hand.

Remove pages

i and ii
3-15 and 3-16
3-16.1/(3-16.2 blank)
B-1 through B-14

Insert pages

i and ii
3-15 and 3-16
3-16.1/(3-16.2 blank)
B-1 through B-14

2. Retain this sheet in front of manual for reference purposes.

By Order of the Secretary of the Army:

GORDON R. SULLIVAN
General, United States Army
Chief of Staff

Official:

MILTON H. HAMILTON
Administrative Assistant to the
Secretary of the Army
07071

DISTRIBUTION:

To be distributed in accordance with DA Form 12-25-E, block no. 3666, requirements for TM 55-1905-223-24-17.

CHANGE
NO. 2

HEADQUARTERS
DEPARTMENT OF THE ARMY
WASHINGTON, D.C., 31 March 1993

Unit, Intermediate Direct Support and Intermediate General Support
Maintenance Instructions

ENVIRONMENTAL CONTROL SUBSYSTEM
FOR
LANDING CRAFT UTILITY (LCU)
NSN 1905-01-154-1191

DISTRIBUTION STATEMENT A: Approved for public release; distribution is unlimited.

TM 55-1905-223-24-17, 17 January 1989, is changed as follows:

1. Remove and insert pages as indicated below. New or changed text material is indicated by a vertical bar in the margin. An illustration change is indicated by a miniature pointing hand.

Remove pages

1-5 and 1-6
3-11 and 3-12
3-13 and 3-14
3-15 and 3-16
- - -

Insert pages

1-5 and 1-6
3-11 and 3-12
3-13 and 3-14
3-15 and 3-16
3-16.1/(3-16.2 blank)

2. Retain this sheet in front of manual for reference purposes.

By Order of the Secretary of the Army:

GORDON R. SULLIVAN
General, United States Army
Chief of Staff

Official:

MILTON H. HAMILTON
Administrative Assistant to the
Secretary of the Army

03956

DISTRIBUTION:

To be distributed in accordance with DA Form 12-25-E, block no. 3666, requirements for TM 55-1905-223-24-17.

CHANGE
NO. 1

HEADQUARTERS
DEPARTMENT OF THE ARMY
WASHINGTON, D.C., 12 June 1991

Unit, Intermediate Direct Support and Intermediate General Support
Maintenance Instructions

**ENVIRONMENTAL CONTROL SUBSYSTEM
FOR
LANDING CRAFT UTILITY (LCU)
NSN 1905-01-154-1191**

Approved for public release; distribution is unlimited.

TM 55-1905-223-24-17, 17 January 1989, is changed as follows:

1. Remove and insert pages as indicated below. New or changed text material is indicated by a vertical bar in the margin. An illustration change is indicated by a miniature pointing hand.

Remove pages

4-47 and 4-48
4-53 and 4-54
B-5 through B-14

Insert pages

4-47 and 4-48
4-53 and 4-54
B-5 through B-14

2. Retain this sheet in front of manual for reference purposes.

By Order of the Secretary of the Army:

CARL E. VUONO
General, United States Army
Chief of Staff

Official:

THOMAS F. SIKORA
Brigadier General, United States Army
The Adjutant General

DISTRIBUTION:

To be distributed in accordance with DA Form 12-25E, (qty rqr block no. 3666)

INSERT LATEST CHANGED PAGES. DESTROY SUPERSEDED DATA.

LIST OF EFFECTIVE PAGES

NOTE: The portion of text affected by the changes is indicated by a vertical line in the outer margins of the page. Changes to illustrations are indicated by miniature pointing hands. Changes to wiring diagrams are indicated by shaded areas.

Dates of original issue and changed pages for this manual are:

Original	17 January 1989	Change 3	30 June 1994
Change 1	12 June 1991	Change 4	30 September 2008
Change 2	31 March 1993		

TOTAL NUMBER OF PAGES IS 336, CONSISTING OF THE FOLLOWING:

Page No.	Change No.*	Page No.	Change No.*
Cover.....	0	3-1 to 3-11	0
Change Transmittal Page No. 4	4	3-12 to 3-14	2
Authentication Page	4	3-15 to 3-16	3
Change Transmittal/Authentication Page No. 3 ...	3	3-16.1/(3-16.2 blank)	3
Change Transmittal/Authentication Page No. 2 ...	2	3-17 to 3-68	0
Change Transmittal/Authentication Page No. 1 ...	1	4-1 to 4-47	0
a/(b blank)	4	4-48	1
A/(B blank).....	4	4-49 to 4-77/(4-78 blank).....	0
i.....	4	A-1/(A-2 blank)	0
ii.....	0	B-1 to B-5	3
1-1	4	B-6.....	0
1-2 to 1-4	0	B-7.....	3
1-5	2	B-8.....	0
1-6 to 1-7	0	B-9.....	4
1-8	4	B-10.....	0
1-9	0	B-11 to B-14	3
1-10	4	C-1 to C-2.....	0
1-11 to 1-22	0	D-1 to D-3/(D-4 blank)	0
2-1 to 2-12	0	Glossary 1 to Glossary 2	0
2-13	4	Index 1.....	0
2-14 to 2-82	0	Index 2.....	4
2-82.1 to 2-82.3/(2-82.4 blank).....	4	Index 3/(Index 4 blank).....	0
2-83 to 2-110	0		

* Zero in this column indicates an original page.

**UNIT, INTERMEDIATE DIRECT SUPPORT, AND INTERMEDIATE
GENERAL SUPPORT MAINTENANCE INSTRUCTIONS**

**ENVIRONMENTAL CONTROL SUBSYSTEM
FOR
LANDING CRAFT UTILITY (LCU)
NSN 1905-01-154-1191**

REPORTING ERRORS AND RECOMMENDING IMPROVEMENTS

You can help improve this publication. If you find any errors, or if you would like to recommend any improvements to the procedures in this publication, please let us know. The preferred method is to submit your DA Form 2028 (Recommended Changes to Publications and Blank Forms) through the Internet, on the Army Electronic Product Support (AEPS) website. The Internet address is <https://aeps.ria.army.mil>. The DA Form 2028 is located under the Public Applications section on the AEPS Public Home Page. Fill out the form and click on SUBMIT. Using this form on the AEPS will enable us to respond quicker to your comments and better manage the DA Form 2028 program. You may also mail, e-mail, or fax your comments or DA Form 2028 directly to the U.S. Army TACOM Life Cycle Management Command. The postal mail address is U.S. Army TACOM Life Cycle Management Command, ATTN: AMSTA-LC-LMPP / TECH PUBS, 1 Rock Island Arsenal, Rock Island, IL 61299-7630. The e-mail address is tacomlcmc.daform2028@us.army.mil. The fax number is DSN 793-0726 or Commercial (309) 782-0726.

Distribution Statement A: Approved for public release; distribution is unlimited.

TABLE OF CONTENTS

	<u>Page</u>
CHAPTER 1 INTRODUCTION	1-1
Section I General Introduction	1-1
Section II Equipment Description and Data	1-2
Section III Principles of Operation.....	1-12
CHAPTER 2 UNIT MAINTENANCE INSTRUCTIONS	2-1
Section I Repair Parts; Special Tools; Test, Measurement, and Diagnostic Equipment (TMDE); and Support Equipment	2-1
Section II Service Upon Receipt	2-1
Section III Unit Preventive Maintenance Checks and Services (PMCS)	2-10
Section IV Unit Maintenance Troubleshooting Procedures	2-17
Section V Unit Maintenance Procedures.....	2-44
Section VI Preparation for Storage or Shipment	2-108

TABLE OF CONTENTS- Continued

CHAPTER 3	INTERMEDIATE DIRECT SUPPORT MAINTENANCE INSTRUCTIONS.....	3-1
Section I	Repair Parts; Special Tools; Test, Measurement, and Diagnostic Equipment (TMDE); and Support Equipment.....	3-1
Section II	Service Upon Receipt	3-1
Section III	Intermediate Direct Support Preventive Maintenance Checks and Services (PMCS) ..	3-2
Section IV	Intermediate Direct Support Troubleshooting Procedures	3-2
Section V	Intermediate Direct Support Maintenance Procedures	3-11
Section VI	Preparation for Storage or Shipment	3-68
CHAPTER 4	INTERMEDIATE GENERAL SUPPORT MAINTENANCE INSTRUCTIONS.....	4-1
Section I	Repair Parts; Special Tools; Test, Measurement, and Diagnostic Equipment (TMDE); and Support Equipment	4-1
Section II	Service Upon Receipt	4-1
Section III	Intermediate General Support Preventive Maintenance Checks and Services (PMCS)...	4-2
Section IV	Intermediate General Support Troubleshooting Procedures.....	4-2
Section V	Intermediate General Support Maintenance Procedures.....	4-13
Section VI	Preparation for Storage or Shipment	4-77
APPENDIX A	REFERENCES	A-1
APPENDIX B	MAINTENANCE ALLOCATION CHART	B-1
APPENDIX C	EXPENDABLE/DURABLE SUPPLIES AND MATERIALS LIST	C-1
APPENDIX D	TORQUE VALUES.....	D-1
GLOSSARY	ABBREVIATIONS AND DEFINITIONS	Glossary 1
ALPHABETICAL INDEX	Index 1

CHAPTER 1

INTRODUCTION

Section I. General Information 1-1

Section II. Equipment Description and Data 1-2

Section III. Principles of Operation..... 1-12

SECTION I. GENERAL INFORMATION

- 1-1. **Scope.** The scope of this manual is as follows:
 - a. Type of Manual. Unit, intermediate direct support, and intermediate general support maintenance manual.
 - b. Model Number and Equipment Name. Environmental Control Subsystem, also referred to as the heating, ventilation, and air conditioning (HVAC) subsystem.
 - c. Purpose of Equipment. Provides heating and/or cooling of air taken into the craft and air circulated within the craft.

- 1-2. **Maintenance Forms, Records, and Reports.** Department of the Army forms and procedures used for equipment maintenance are those prescribed by DA Pam 738-750, the Army Maintenance Management System.

- 1-3. **Destruction of Army Materiel.** Refer to TM 750-244-3 for instructions covering the destruction of Army materiel to prevent enemy use.

- 1-4. **Reporting Equipment Improvement Recommendations (EIR).** You can help improve this publication. If you find any errors, or if you would like to recommend any improvements to the procedures in this publication, please let us know. The preferred method is to submit your DA Form 2028 (Recommended Changes to Publications and Blank Forms) through the Internet, on the Army Electronic Product Support (AEPS) website. The Internet address is <https://aeps.ria.army.mil>. The DA Form 2028 is located under the Public Applications section on the AEPS Public Home Page. Fill out the form and click on SUBMIT. Using this form on the AEPS will enable us to respond quicker to your comments and better manage the DA Form 2028 program. You may also mail, e-mail, or fax your comments or DA Form 2028 directly to the U.S. Army TACOM Life Cycle Management Command. The postal mail address is U.S. Army TACOM Life Cycle Management Command, ATTN: AMSTA-LC-LMPP / TECH PUBS, 1 Rock Island Arsenal, Rock Island, IL 61299-7630. The e-mail address is tacomlcmc.daform2028@us.army.mil. The fax number is DSN 793-0726 or Commercial (309) 782-0726.

- 1-5. **Preparation for Storage or Shipment.** Administrative storage of equipment issued to and used by Army activities will have preventive maintenance performed in accordance with the Preventive Maintenance Checks and Services (PMCS) charts before storing. When removing the equipment from administrative storage, the PMCS should be performed to assure operational readiness. Repacking of equipment for shipment or short term storage is covered in paragraph 2-36.

SECTION II. EQUIPMENT DESCRIPTION AND DATA

- 1-6. General Description.** The environmental control subsystem, also referred to as HVAC (heating, ventilation, and air conditioning), provides heating and/or cooling of air taken into the ship and air circulated within the ship. The subsystem maintains a clean, comfortable atmosphere in the living and working spaces, and provides air flow in other spaces to maintain proper temperature and ventilation. Spaces that produce excessive heat, such as the engine rooms, auxiliary machinery rooms, and galley areas; and vapor-producing spaces such as flammable liquid storerooms and paint mixing rooms, are served by the supply and exhaust ventilation systems, which vent to the outside air. The subsystem is an integrated system of fans, air conditioning and heating units, piping and ducting, and controls that are manually started and thermostatically control the subsystem.
- 1-7. Characteristics, Capabilities, and Features.** The environmental control subsystem equipment, shown in FIGURE 1-1, is the equipment required to heat, ventilate, and air condition the living and working spaces aboard the vessel.
- a. Heating System. The heating system consists of duct heaters, unit heaters, and convection heaters.
- (1) Duct Heaters
- Flanged type, mounted in supply air ducts
 - Metal sheath electric heating elements
 - Manual and automatic start
 - Thermostat controlled
 - Manual and automatic reset
 - Thermal cutouts
 - Heaters over 48 amps are individually fused
 - Liquid proof terminal box/sealed joints
- (2) Unit Heaters
- Self-contained, continuous duty space heaters
 - Wall or ceiling bracket mounted
 - Electric heating coils
 - Forced air (fan)
 - Manually operated
 - Paint locker heaters fitted with explosion proof motor
 - Manual and automatic reset
 - Built-in time delay fan
 - Built-in thermostat and controls
 - Built-in thermal overload protection
 - Totally enclosed unit
- (3) Convection Heaters
- Self-contained space heaters
 - Wall mounted
 - Electric heating coils

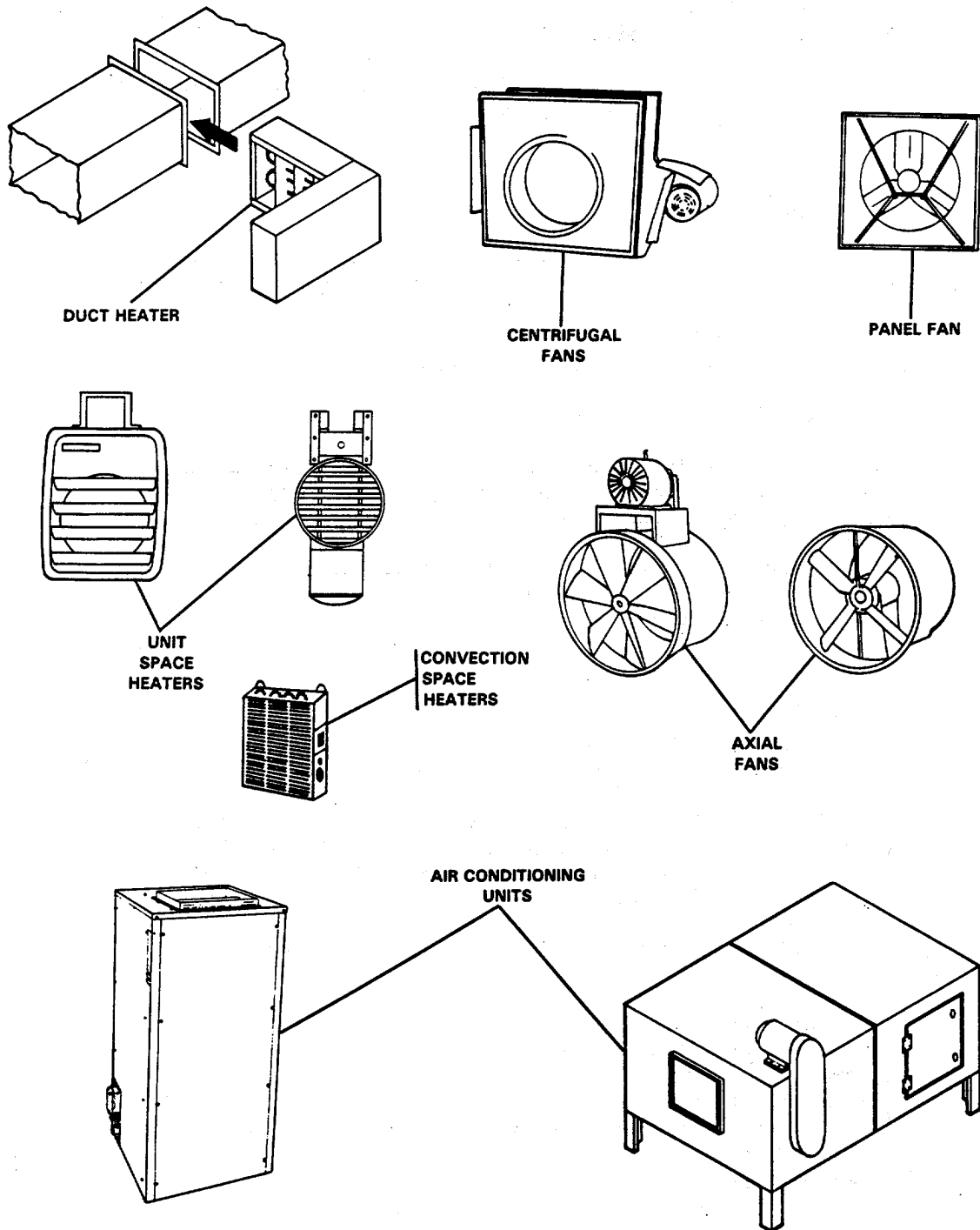

Figure 1-1. Major Components in Environmental Subsystem (HVAC).

Natural convection fan
 Manual ON/OFF
 Internal adjustable thermostat

- b. Ventilation System. The ventilation system consists of the axial, centrifugal, and panel fans in the supply air and exhaust air systems.

(1) Axial Fans

Duct mounted
 Electric motor
 V-belts on belt drive fans are oil, heat, and static resistant
 Manually started
 Self-aligning
 One-piece propeller and hub construction
 Access doors for cleaning and maintenance

2) Centrifugal Fans

For small to medium exhaust and supply ventilation applications (toilets, galley hood, and A/C-emergency generator room)
 Electric, easy access motor
 V-belt drive
 Hinged motor mount to aid in belt adjustment
 Non-overloading backward inclined wheel (fan)
 Manually operated

(3) Panel Fan

Small, blade type ring fan
 Panel mounted with guard
 Direct drive

- c. Air Conditioning (Recirculation) System. The recirculation air system consists of three air conditioning units that provide local filtering and cooling of air to the pilothouse, equipment operating spaces (EOS), and living spaces on the vessel. The system contains two 3-ton units and one 16-ton unit.

(1) 3-Ton Koldwave refrigeration units (A/C-1, pilothouse; and A/C-3, engine control room)

Self-contained unit
 Hermetic (sealed) compressor
 Thermostat controlled
 Manual and automatic start
 Direct motor drive fan (blower)
 Direct expansion coil
 Condensate pump

Seawater cooled condenser
 Replaceable air filters
 High pressure cut-off solenoid

(2) 16-Ton McQuay/Carrier Refrigeration Unit (A/C-2, accommodations)

Seawater heat exchanger (condenser)
 Thermostat controlled
 Manual and automatic start
 Belt driven fan (blower)
 Thermostatic expansion valve
 Filter/dryer (moisture collector)
 6 cylinder semi-hermetic compressor with internal oil pump
 Replaceable air filters
 High and low pressure cut-offs
 Hot gas defrost

1-8. Location and Description of Major Components. FIGURE 1-1 shows the major components in the environmental control subsystem. Tables 1-1 thru 1-6 list components, areas served, and electrical specifications of the components in the system. For the locations of ducting, duct component, and remote mounted controls, refer to TM 55-1905-223-10.

1-9. Equipment Data. Tables 1-1 through 1-6 list spaces served by the HVAC and reference data for the major components in the subsystem. Table 1-7 provides the manufacturer's names, model numbers, and other equipment data for the fans and heaters, listed by component unit number. Table 1-8 gives reference data for the air conditioning units. Also see the equipment data given in the operator's manual, TM 55-1905-223-10.

NOTE

Temperature settings are recommended reference points. Settings may require variations according to ambient temperatures.

Table 1-1. Duct Heaters (DH)

NO.	SPACE SERVED	KW REQD	VOLT/ PHASE	CFM	APERTURE DIMENSIONS WIDTH X HEIGHT
DH-1	Preheater/Accommodations Air Preheat Thermostat Settings; Thermostat 1-48°F Thermostat 2-42°F	19.10	240/3	1200	49.125 x 23.875 inch
DH-2	Pilothouse	12.00	240/3	1200	24W x 10H
DH-3	Galley (Make Up Air) Port Side	35.00	240/3	1725	24W x 10H
DH-4	Chief Engineer Stateroom	0.50	110/1	140	6W x 6H
DH-5	Crew SR 01 Level	1.00	240/3	155	8W x 6H
DH-6	Crew SR 01 Level	0.50	110/1	150	8W x 6H
DH-7	Crew SR 01 Level	1.00	240/3	200	8W x 6H
DH-8	Crew SR 01 Level	1.75	240/3	390	10W x 8H
DH-9	Laundry Room	0.50	240/3	65	12W x 8H
DH-10	Captain Stateroom	1.00	240/3	170	6W x 6H
DH-11	Mess Room	2.00	240/3	705	18W x 10H
DH-12	Galley	0.50	240/3	200	24W x 18H
DH-12A	Galley	0.50	240/3	200	24W x 18H
DH-13	Pantry	1.50	240/3	250	10W x 6H
DH-14	Arms Control Room	0.50	110/1	85	6W x 4H
DH-15	Sick Bay	1.50	110/1	200	8W x 6H
DH-16	Recreation Room	1.00	240/3	330	12W x 6H
DH-17	Engine Control Room	1.00	240/3	100	4W x 4H

Table 1-2. Unit Heaters (UH)

NO.	SPACE SERVED	KW	VOLT/PHASE
UH-1	Engine Room (Starboard)	15	240/3
UH-2	Engine Room (Port)	15	240/3
UH-3	Steering Gear Room	10	240/3
UH-4	Tunnel (Forward)	10	240/3
UH-5	Bowthruster Room	10	240/3
UH-6	Emergency Generator Room	1	240/3
UH-7	Bosun Storeroom	5	240/3
UH-8	Paint Locker (Storeroom)	5	240/3
UH-8A	Paint Locker (Storeroom)	5	240/3
UH-9	Machine Shop	5	240/3
UH-10	Tunnel (Aft)	10	240/3
UH-11	Machinery Storeroom	5	240/3

Table 1-3. Convection Heaters (CH)

NO.	SPACE SERVED	KW	VOLT/PHASE	CFM
CH-1	Crew Water Closet 01 Level	1.0	240/3	340
CH-2	Crew Water Closet 01 Level	0.5	110/1	90
CH-3	Stateroom WC 01 Level	0.5	110/1	60
CH-4	Sick Bay Water Closet	0.5	110/1	200

Table 1-4. Exhaust Fans (EF)

NO.	SPACE(S) SERVED	TYPE FAN	CFM	S.P.	RPM	HP	VOLT/ PHASE
EF-1	Engine Room (Port)	Axial	30,000	1.0	1800	15	230/3
EF-2	Engine Room (Starboard)	Axial	30,000	1.0	1600	15	230/3
EF-3	Steering Gear Room	Axial	2,000	1.0	1200/1600	1	230/3
EF-4	Toilets 02 Level	Center	700	0.5	1750	1/3	230/3
EF-6	Galley Hood	Center	1,500	2.5	1750	1 1/2	230/3
EF-7	Paint Locker	Center		-	1725	1	230/3

Table 1-5. Supply Fans (SF)

NO.	SPACE(S) SERVED	TYPE FAN	CFM	S.P.	RPM	HP	VOLT/ PHASE
SF-1	Engine Room (Starboard)	Axial	32,800	1.0	1800/900	20	230/3
SF-2	Engine Room (Port)	Axial	32,800	1.0	1800/900	20	230/3
SF-3	Machine Shop Storeroom-Tunnel	Axial	1,425	1.25	3600/1800	3/4	230/3
SF-4	Bowthruster Room	Axial	4,600	1.0	3600/1800	3	230/3
SF-5	A/C and Emergency Generator Room	Center	300	0.5	1750	1/4	230/3
SF-6	Galley (Make Up) Air	Axial	1,250	0.75	1725	1 1/2	230/3
SF-7	Forward DC Locker	Axial	150	0.25	3000	1/64	115/1
SF-8	Aft DC Locker	Axial	150	0.25	3000	1/64	115/1

Table 1-6. Air Conditioning Units (A/C)

NO.	SPACE(S) SERVED	CFM	TONS		VOLT/PHASE	MINIMUM	
			S.P.	REFR.		CIRC.	AMP
A/C-1	Pilothouse	2,050	1.0	3	230/3	30	45
A/C-2	Accommodations/Living Spaces	6,000	2.0	16	230/3	70	110
A/C-3	Engine Room-Control Room	2,050	1.0	3	230/3	30	45

Table 1-7. Heater and Fan Equipment Data

UNIT	MANUFACTURER	MODEL	MOTOR SIZE	TYPE	DRIVE
DH-1	Indeeco	TFZU			
DH-2 thru 17	Markel	CHMS-3-F			
UH-1 and 2	Chromalox	LUH-B-15-23-34-40			
UH-4 and 10	Chromalox	LUH-B-10-23-34-40			
UH-9 and 11	Chromalox	LUH-B-5-23-34-40			
UH-3 and 5	Indeeco/ Triad	234-U11N-0100K-3090			
UH-6	Indeeco/ Triad	234-U11N-0010K-3091			
UH-7	Indeeco/ Triad	234-U11N-0050K-3092			
UH-8 and 8A	Indeeco	236-F01S-0052K-4087 Explosion Proof Type			
CH-1	Vilad	DFM-11.0-1			
CH-2 thru 4	Vilad	DFM-10.5-1			
EF-1 and 2	Hartzell	65-35-AV03	FR-254T	Axial	Direct
EF-3	Bayley	DTA-16-6G36I	FR-56	Axial	Direct
EF-4	Bayley	OV122	FR-56	Centrifugal	Belt
EF-6	Bayley	OV135	FR-145T	Centrifugal	Belt

■ Table 1-7. Heater and Fan Equipment Data - CONT.

UNIT	MANUFACTURER	MODEL	MOTOR SIZE	TYPE	DRIVE
EF-7	Bayley	B 135 D	1 HP	Centrifugal	Belt
SF-1 and SF-2	Hartzell	65-35-AVP-3	20 HP	Axial	Direct
SF-3	Hartzell	44-12-DG2	3/4 HP	Axial	Direct
SF-4	Bayley	BV16-7G29L	3 HP	Axial	Belt
SF-5	Bayley	TD12-3Y18B	1/4 HP	Panel	Direct
SF-6	Bayley	BTA12-8G36I	1 1/2 HP	Axial	Belt
■ SF-7 and SF-8	Howden Buffalo	500702-4036	1/64 HP	Axial	Direct

Table 1-8. Air Conditioning Equipment Data

CHARACTERISTICS	REFERENCE DATA
<u>Units A/C-1 and A/C-3</u>	
Manufacturer	Koldwave
Model	KC33D (Single unit/self-contained)
Nominal cooling capacity	3 tons/36,000 BTU
Refrigerant type	R-22
Fan type	Centrifugal, direct drive
Fan motor	1/2 hp, 2 speed
Compressor	Hermetically sealed (welded)
Condenser	Water-cooled
Operating Pressures	
Maximum discharge	300 psig
Normal discharge	190 to 275 psig
Minimum discharge	170 psig
Maximum suction	85 psig
Normal suction	55 to 72 psig
Minimum suction	50 psig (cut-out at 5 psi)
High pressure cut-out setting	275 psig
Weight of assembly	300 lbs
Filter size (inches)	18 x 23 x 1/2
<u>Unit A/C-2</u>	
Manufacturer	McQuay
Model	LSL-106 (upper cabinet and components only)
Condenser	Seawater cooled
Manufacturer	Doucette
Model	SW18 3/4 M3 3/4

Table 1-8. Air Conditioning Equipment Data-CONT

CHARACTERISTICS	REFERENCE DATA
<u>Unit A/C-2. continued</u>	
Water regulating discharge pressure	210 psig (head pressure)
Blower motor	5 hp, 1800 rpm
Manufacturer	Louis-Allis
Type/size	COG4B/FR 184T
Compressor	
Manufacturer	Carrier
Model	6D75-537
Cylinders	6
Stroke	1-15/16 inch
Bore	2-inch
Speed	1750 rpm
Horsepower	12.7
Design temperature parameters:	
Summer:	outside DB 95°F/WB 89°F/RH 79%
	inside DB 75°F/WB 68°F/RH 50%
Winter:	outside 0°F
	inside 65°F
Nominal cooling capacity	16 ton/180,000 btu at: 40° F suction temperature; 110°F condensing temperature
Return air thermostat setting	75°F
Cooling coil leaving temperatures	57°F to 60°F
Operating Pressures	
Maximum discharge	250 psig
Normal discharge	170 to 230 psig
Minimum discharge	150 psig
Maximum suction	85 psig
Normal suction	58 to 72 psig
Minimum suction	52 psig (cut-out at 5 psi)
Oil Pressures	
Maximum (above suction pressure)	55 psig
Minimum (above suction pressure)	10 psig
Oil failure cutout	10 psi
Hot gas valve opens automatically	53 psig (factory preset)
Pressure relief valve setting	400 psi
Refrigerant type and charge	R-22/30 lb
Weight	1572 lb (cabinet and cabinet components only)
Filters (inches)	16 x 20 x 2
Quantity	6

- 1-10. Safety, Care, and Handling.** Safety precautions must be observed at all times while performing maintenance. General WARNINGS and first-aid data appear in the front of this manual. Review all safety information before starting any task. Carefully read through an entire maintenance procedure before performing any maintenance function. Make sure the task can be done safely. All WARNINGS, CAUTIONS, and NOTES are of great importance to your safety and the safety of the equipment.

SECTION III. PRINCIPLES OF OPERATION

- 1-11. Supply System General.** The heating, ventilation, and air conditioning process begins as weather air enters the HVAC supply intakes. Initial air conditioning begins with the air being filtered. Filters are located in each recirculation system. In the heating cycle, air in the supply intake is heated by an electric preheater which is thermostatically controlled. Supply fans move the air through the supply ducts to ventilate compartments and to heat or cool the air. Natural air supply to toilet and shower spaces is through door undercuts or door louvers. FIGURE 1-2 shows a typical ventilation arrangement for heating and cooling. Refer to TM 55-1905-223-10 for actual arrangement of heating, ventilation, and cooling equipment in each compartment aboard the vessel.
- 1-12. Supply Air System.** Supply air, which is weather air, is drawn into the vessel by the ventilation supply fans. The air intake trunks (ducts) are the major supply systems feeding air into the vessel. Each trunk has an associated weather opening in addition to a supply air fan. Downstream of the air intake, electric heaters are mounted in the ducts with thermostatic controls set to activate only in cold weather. The air supply trunk serves more than one ventilation or air conditioning system within the vessel. An electric heater in the intake duct serves as a preheater and is energized by a thermostat when the incoming outside air is below the thermostat set point. Heating the air as it enters the vessel eliminates duct sweating that would otherwise occur in cold weather. The supply system provides fresh outside air to ventilated compartments and replenishes air to air conditioned compartments.

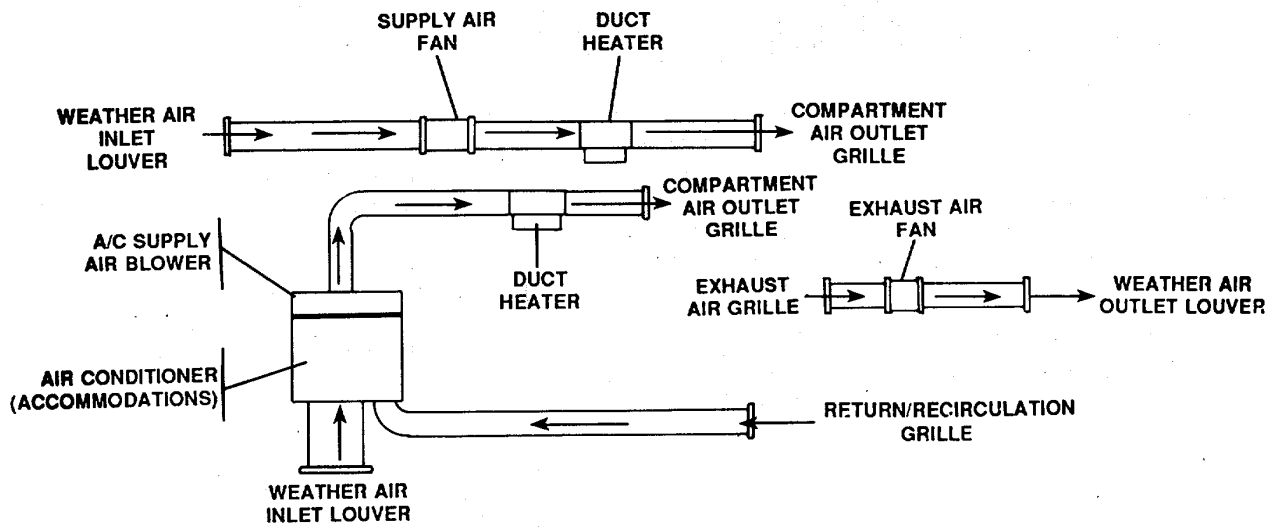

A

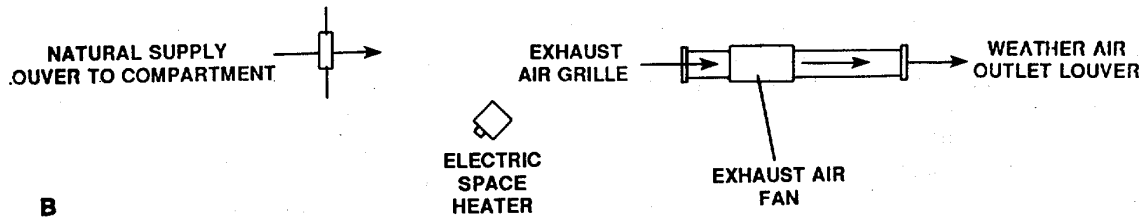

B

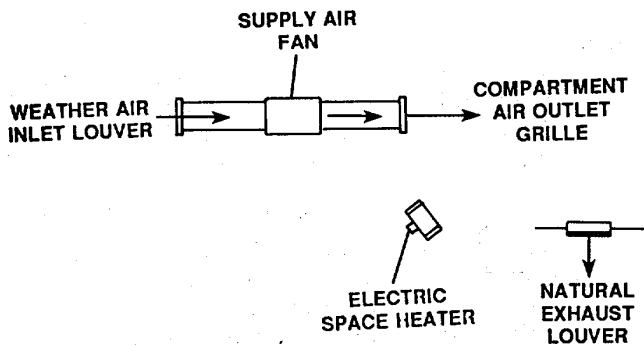

C

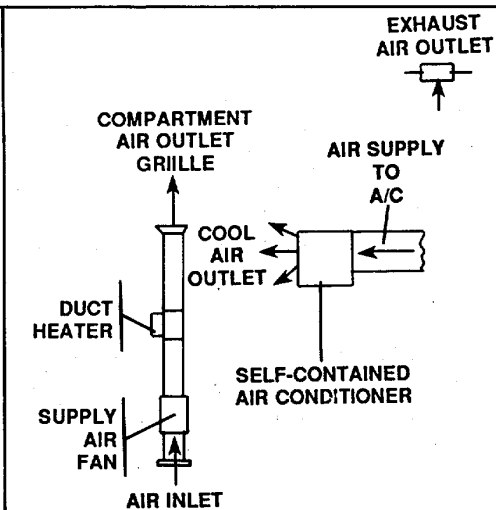

D

Figure 1-2. Typical Arrangements for Heating, Ventilating and Compartments.

- a. Cooling of Supply Air. To provide cooling, the supply (replenishment) air is routed through the air conditioning units which operate automatically under the control of compartment thermostats to maintain set temperatures.
- b. Heating of Supply Air. To provide heating, the supply air is routed through electric heaters installed in the supply air ducts. The duct heaters operate automatically under thermostatic control to maintain compartment temperatures. Each duct heater is equipped with an air flow switch which automatically shuts down the heater when the supply air flow through the heater is interrupted or stopped. Some ventilated compartments contain electric space heaters which are self-contained units and are controlled by internal thermostats and manual ON/OFF switches.
- c. Dampers. Certain supply air intakes are equipped with dampers which may be closed to prevent toxic or dangerous vapors from entering the vessel (see TM 55-1905-223-24-18 for damper locations).

- 1-13. Exhaust Air System.** The exhaust system and fans discharge air from the vessel to the atmosphere. The exhaust fans draw approximately the same volume of air out of the vessel as the supply fans bring into the vessel. The exhaust system consists of fans and ducting components. There is no heating, cooling, or filtering of air in the exhaust system. The axial and centrifugal fans in the exhaust system move the air through the exhaust ducts and discharge it to the atmosphere. Natural exhaust from staterooms is through door louvers.
- 1-14. Recirculation (Return Air) System.** The recirculation system consists of air ducts, fans, and air conditioning units serving the living and working spaces. The recirculation system provides local filtering and reheating or cooling of air. The recirculation system mixes a calculated quantity of replenishment air supplied by the supply air fans into the recirculated air and vents an approximately equal volume of air through the exhaust system in a continuing process. The recirculation system takes the air already in compartments and recirculates it through ducts, fans, heaters, or air conditioner cooling coils.
- 1-15. Galley Make-Up and Exhaust Air.** The galley exhaust fan removes air from the area along with all cooking smoke and odors. To prevent all air conditioning (cool air) from being sucked out of the area, this exhausted air must be replenished with fresh air. The exhausted air is replenished with a make-up supply air fan. This leaves a slight negative pressure on the galley to help prevent migration of cooking smoke and odors to other parts of the vessel. The fan supplies the fresh air through a duct system around the perimeter of the exhaust hood.
- 1-16. Cooling Cycle and Major Components.** The major components in an air conditioning cooling cycle are the cooling coil, the compressor, the condenser, and the expansion valve (or a capillary tube assembly in self-contained units). FIGURE 1-3 shows the interface of these components in the basic cooling cycle. FIGURE 1-3 is a simplified typical arrangement showing major components only.

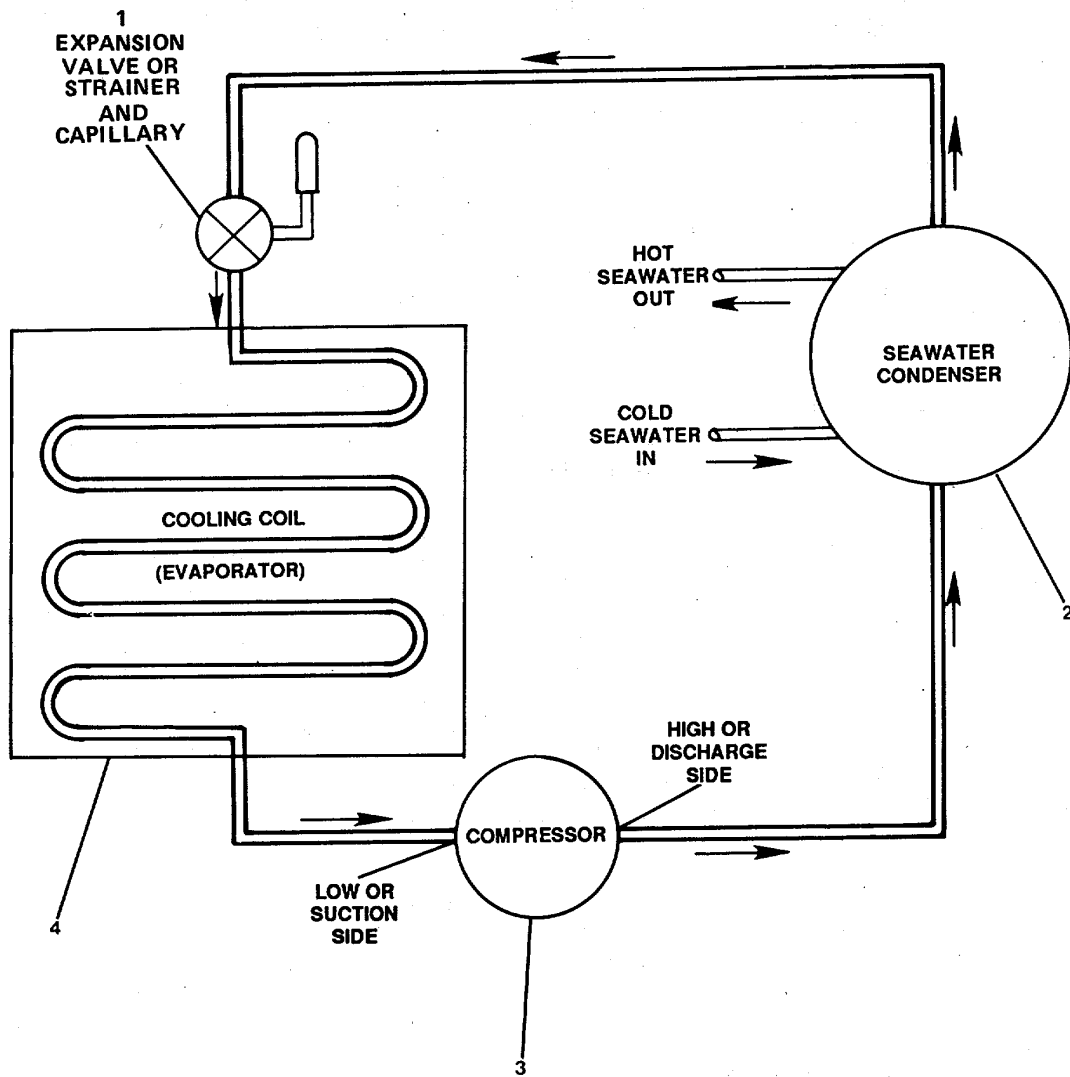

Figure 1-3. *Interface of Major Components in the Cooling (Air Conditioner) Cycle .*

- a. Cooling Cycle. The cooling cycle shows what happens to the heat after it is removed from the air by refrigerant in the cooling coil.
- (1) As cold refrigerant liquid moves through the cooling coil (4, FIGURE 1-3), it picks up heat from the air passing over the surface of the coil. As it picks up heat, the refrigerant changes to a vapor.
 - (2) The heated refrigerant vapor is then drawn into the compressor (3) where it is put under high pressure. This causes the temperature of the vapor to increase.
 - 3) Next, the high pressure, high temperature vapor passes to a seawater cooled condenser (2) where heat is removed from the refrigerant. As the condenser removes heat, the vapor changes to a liquid but is still under pressure.
 - (4) The liquid refrigerant then flows to the expansion valve (1) (or capillary assembly). As the liquid flows through the valve (or capillary), pressure is reduced instantaneously. This action lowers the temperature of the liquid still further so that it is now ready to pick up more heat.
 - (5) The cold, low pressure liquid refrigerant then flows into the cooling coil (4). The pressure in the cooling coil is low enough to allow the refrigerant to vaporize as it again absorbs heat from the air passing over the coil surface. The cycle begins to repeat itself as the heated refrigerant vapor is again drawn into the compressor (3).
- b. Cooling Coil. The purpose of the cooling coil is to provide a surface over which air from a compartment can flow, and at the same time, a passage through which refrigerant can flow. The combination of warm air flowing over the cold refrigerant tends to cool the air and heat the refrigerant. Actually the temperature of the refrigerant does not change; but the liquid does change to a vapor, and in this sense, the refrigerant is heated. So, in effect, heat is transferred from the air to the refrigerant through the coil (heat transfer) surface.
- c. Compressor. The compressor serves two purposes; first, it draws the refrigerant from the-cooling coil and forces it into the condenser and secondly, it increases the pressure on the refrigerant.
- (1) Compressor Suction. By drawing or sucking the refrigerant, the compressor reduces the pressure in the cooling coil and maintains it at a level low enough to permit the refrigerant to vaporize (boil) and consequently absorb heat in the process. Refrigerant boils at a relatively low temperature when pressure is reduced.
 - (2) Compressor Discharge. By discharging or forcing refrigerant into the condenser, the compressor increases the pressure of the refrigerant. In doing so, the compressor actually increases the refrigerant vapor temperature. This makes it easier for the condenser to do its job.

- d. Condenser.
- (1) The condenser serves two important functions:
 - (a) It removes the heat picked up by the refrigerant in the cooling coil.
 - (b) It condenses the refrigerant vapor to a refrigerant liquid.
 - (2) The heat removal and condensing processes take place by a water cooling process. The refrigerant vapor is passed through an outer shell of the condenser tubes and cool seawater passes through an inner shell, or tubing (FIGURE 1-4). The seawater supplied to the condenser is at a lower temperature than the temperature of the refrigerant vapor. Heat from the refrigerant is transferred to the seawater through the inner tubing walls. The seawater then carries the heat from the condenser through a discharge or drain line. The condenser removes enough heat to change the refrigerant from a vapor to a liquid.
- e. Expansion Valve. FIGURE 1-5 illustrates the principle of both the expansion valve method and the capillary tube method of metering the refrigerant flow.

NOTE

The self-contained air conditioning units use a capillary tube assembly in the place of an expansion valve. However, the principle, or function, of supplying refrigerant to the cooling coil is the same in both methods.

- (1) Expansion Valve Method. The expansion valve reduces the pressure of the refrigerant liquid, and in doing so, it cools the liquid. Refrigerant enters the valve under pressure. As it passes through a small valve port, it enters the low pressure area of the cooling coil. The valve port acts as a metering device between a high pressure area (the condenser), and a low pressure area (the cooling coil). As the pressure is reduced, the point at which the liquid becomes a vapor is also reduced. Therefore, after the liquid refrigerant passes through the metering port in the expansion valve, it begins to vaporize in the cooling coil because it is now in a low pressure area.
- (2) Capillary Tube Method (Self-Contained A/C Units). The principle, or function, of the capillary tube method is the same as that of the expansion valve method. The basic difference in the two methods is that the refrigerant is metered through a series of long, small diameter capillary tubes instead of through a single, small valve port. (See FIGURE 1-5.)

NOTE

The number of capillary tubes will vary in different types of air conditioners.

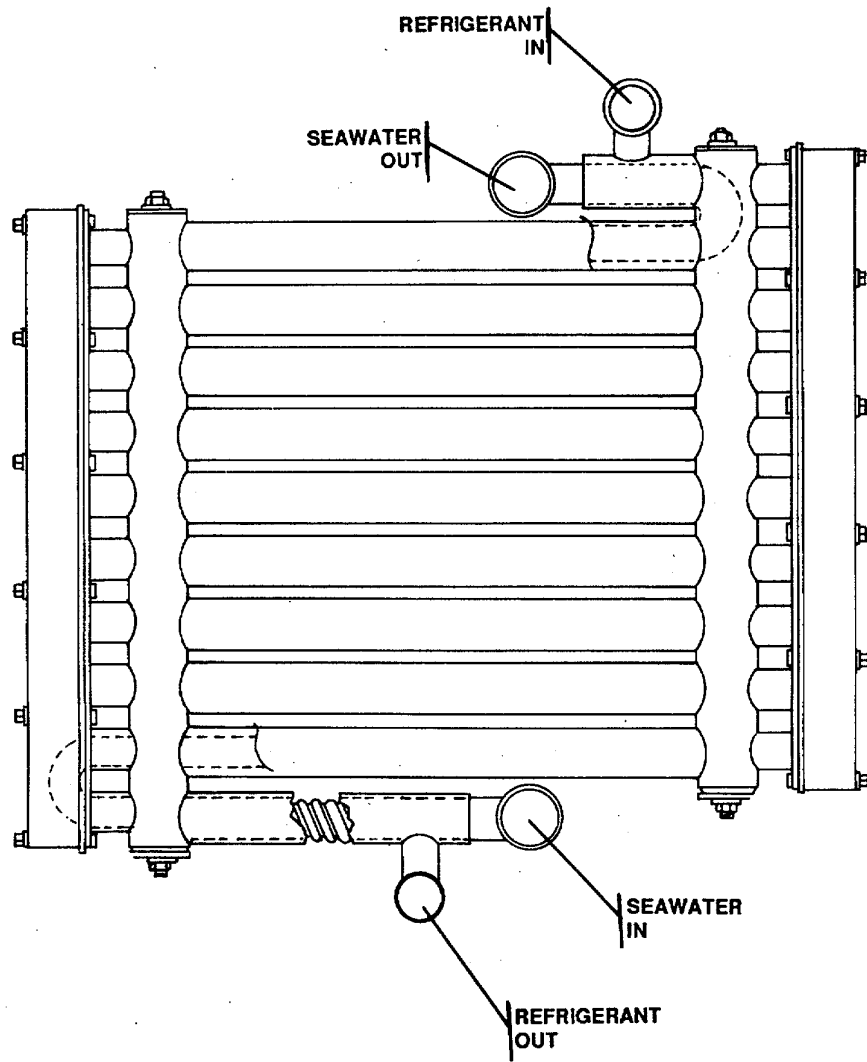

Figure 1-4. Water Cooling Process in Condenser.

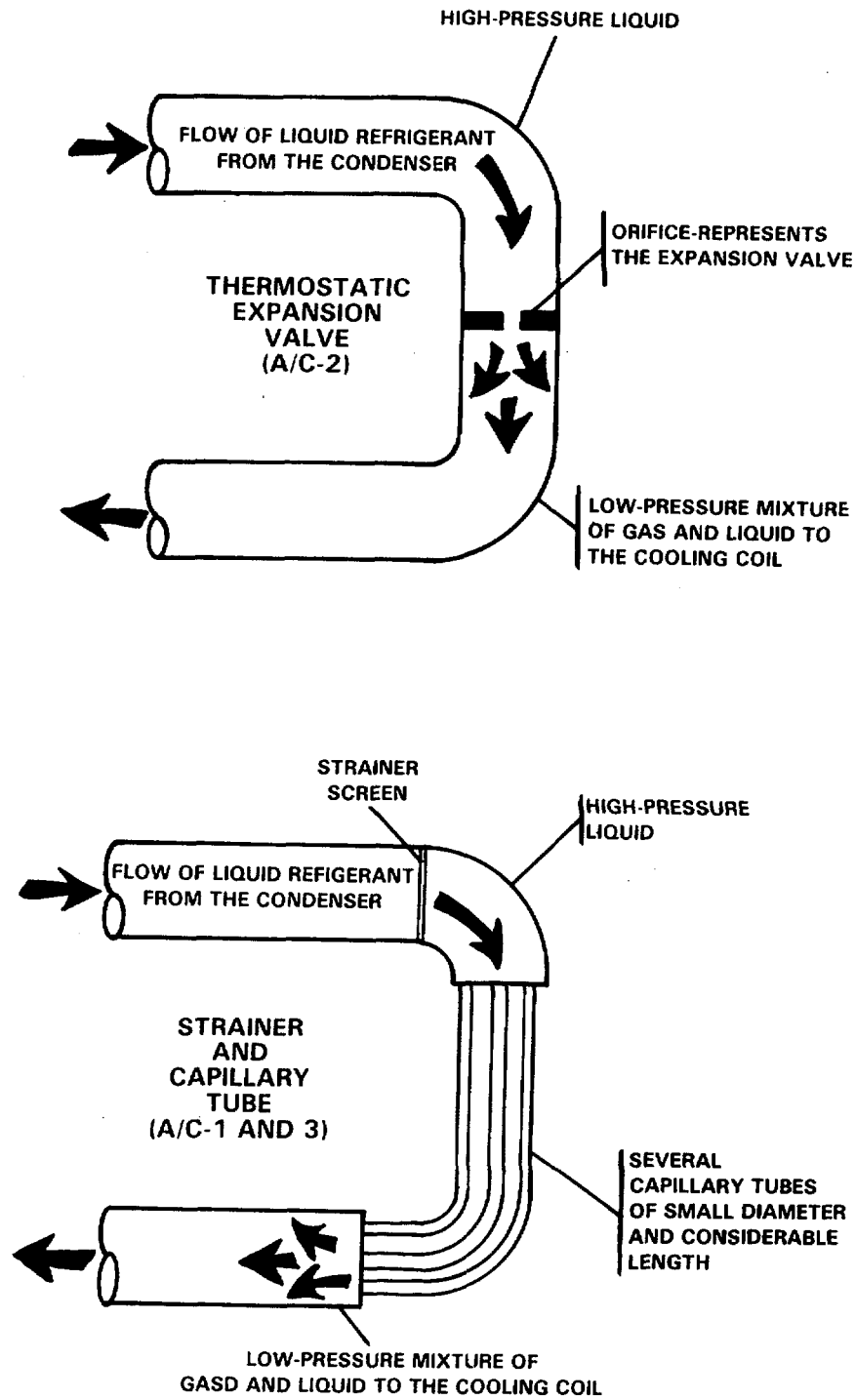

FIGURE 1-5. Methods of Metering Refrigerant Flow to the Cooling Coil (Evaporator).

1-17. Function of HVAC Accessories. Maintenance personnel should be familiar with the basic function of the following accessories in the heating and cooling equipment in the subsystem.

a. Electrical Components Used with Duct Heaters

- (1) Automatic Reset Thermal Cut-Out (ARTC). This is a thermally operated safety device that may be either a bulb and capillary type or a disk type. This safety device is required to deenergize the entire heater to prevent overheating. The automatic reset thermal cut-out may be capable of handling small single phase loads or may require the use of a contactor for larger single phase and three phase loads.
- (2) Heat Limiters. Sometimes called replaceable thermal cutoffs, these comprise one of the methods of secondary thermally operated safety devices to protect the system against overheating in the event of failure of the primary safety device, the automatic reset thermal cut-out and its circuit. Heat limiters are set to operate at higher temperatures than the automatic reset thermal cut-out. The heat limiters are normally installed in the power lines and open in case of a double failure, that is, overheating of the system and failure of the primary safety device. Wired this way the heat limiters are also independent of any contactor which may be used in the operating circuit.
- (3) Manual Reset Thermal Cut-Out (MRTC). This is an alternate resettable secondary thermally operated safety device set to operate at a higher temperature than the automatic reset thermal cut-out. The manual reset thermal cut-out must either be in the power legs rated to handle the resistive load and break a sufficient number of conductors to deenergize the heater. If any of the manual resets is tripped, then it is necessary to correct the unsafe conditions and reenergize the heater by pressing the reset button.
- (4) Contactors. A contactor is an electrical device which magnetically pulls in to close an electric power circuit when the holding coil in the contactor is energized. Contactors are used when either the control thermostat or the safety cut-outs or an air flow switch do not have sufficient electrical rating to carry the resistive load.
 - (a) Operating Contactors. These contactors are required to switch the electric load of each heater's step and are operated by the control device, the automatic reset thermal cut-out, or the air flow switch.
 - (b) Back-Up Contactors. These are used for manual reset thermal cut-outs operating a second set of contactors in series with the operating or safety contactors.
- (5) Room Thermostats. This is a temperature control device that is mounted on the wall in the area which it serves. The voltage ratings of the thermostats must conform with the control voltage of the heater.
- (6) Duct Thermostats. This is a contact device with a remote bulb mounted in the duct or plenum of an air handling unit to measure air temperature. The bulb is mounted in such a way that it does not see radiant heat directly from the heater.

- (7) Air Flow Switch. This is a device designed to prevent the heater from operating when there is no air in the duct. The pressure differential air flow switch measures the total pressure difference between the inside of the duct and the outside. The total pressure is the summation of the static pressure and velocity pressure. In critical low pressure situations, it is important to turn the sensing tube into the air stream so that the velocity pressure is also measured. Since the manufacturer may not know the direction of air flow, this is a field adjustment. The air flow switch is connected in the control circuit in series with the control thermostat and automatic reset thermostat controlling the operating contactor.
- (8) Overcurrent Protective Device. Overcurrent protective devices are required for any circuit that is over 48 amperes. This protection is in the form of fuses and resettable circuit breakers. The overcurrent protection devices may be built into the terminal box of the heater or in a remote control panel.
 - (a) Safety Disconnect Switch. This is a switch that interlocks with the box or panel door. The switch insures that the terminal box is not "live" electrically when the door is opened.
- b. Components Used in Air Conditioning (Cooling Cycle).
 - (1) Thermostats. Refer to a.(5) and (6) of this paragraph.
 - (2) Contactors. Refer to a.(4) of this paragraph.
 - (3) Time Delay Device.
 - (a) A time guard circuit prevents compressor short cycle by providing a 5 minute delay before restarting the compressor after shutdown for any reason. On startup, the timer causes a 15-second delay before the compressor can start.
 - (b) On compressor shutdown, the timer runs for 4 minutes 45 seconds. During this time the compressor cannot start.
 - (4) High and Low Pressure Controls. The high pressure control switch is a safety device which stops the compressor in the event of excessive pressure in the high (discharge) side of the system. The low pressure control switch is a safety device which stops the compressor in the event of low pressure in the low (suction) side of the system. Either switch prevents the compressor from restarting until the pressure returns to its cut-in setting (no low pressure control on self-contained units).
 - (5) Filter Dryer. The filter dryer is installed in the liquid line, and is filled with activated alumina or silica gel which has the ability to attract and hold moisture. It is also a filter preventing contaminants from entering the expansion valve, or capillaries, and the rest of the system.

- (6) Water Regulating Valve.
 - (a) The water regulating valve on self-contained units (A/C 1 and 3) is automatic and non-adjustable. These valves are set for 95° F outlet water temperature. The regulating valve on A/C 2 (accommodations) is adjustable and is designed for 210 psig discharge (head) pressure.

- (7) Moisture Indicator (A/C-2; Accommodations). Moisture indicator is placed in refrigerant line to show the wet or dry condition of the refrigerant. The indicator has a viewing glass that shows a positive change from green (dry condition) to yellow (wet condition). When the indicator shows yellow, the system must be purged, evacuated, and recharged with R-22.

- (8) Refrigeration Ball Check Valves (A/C-2; Accommodations). Ball check valves are placed in refrigerant lines to control the direction of flow through the lines. Two types of valves are used in the system.
 - (a) Valve with Visual Exposed OPEN/CLOSE Indicator. This type of valve can be visually checked to determine if it is opened or closed. This type of valve is manually opened or closed by turning the indicator stem 1/4 turn.
 - (b) Valve with Unexposed OPEN/CLOSED Indicator. This type of valve has a brass seal cap that must be removed to expose the OPEN/CLOSED indicator. This type valve is also manually opened or closed by turning the indicator stem 1/4 turn.

- (9) Refrigerant Receiver (A/C-2; Accommodations). The receiver is a tank, or cylinder, located in the liquid refrigerant (high side) line that serves three purposes on large air conditioning units. The smaller self-contained units do not have a receiver.
 - (a) Acts as a refrigerant surge suppressor from the compressor pump and condenser where the pump and condenser are overloaded for short periods of time.
 - (b) Stores a sufficient amount of liquid refrigerant to keep the expansion valve adequately supplied when small leaks may occur over long periods of time.
 - (c) The receiver is large enough to hold most of the refrigerant when pumping down the system.

- (10) Hot Gas Valve (A/C-2; Accommodations). During low-load periods, the hot gas valve opens, allowing hot gas to flow to the cooling coil. This action induces the air conditioner to run longer, avoiding shut run cycles. When demand cycles the air conditioner off, a solenoid on the hot gas valve closes. This action prevents the hot gas valve from keeping the system running longer than necessary.

CHAPTER 2

UNIT MAINTENANCE INSTRUCTIONS

	<u>Page</u>
Section I. Repair Parts, Special Tools; Test, Measurement, and Diagnostic Equipment (TMDE); and Support Equipment.	2-1
Section II. Service Upon Receipt	2-1
Section III. Unit Preventive Maintenance Checks and Services (PMCS)	2-10
Section IV. Unit Maintenance Troubleshooting	2-17
Section V. Unit Maintenance Procedures	2-44
Section VI. Preparation for Storage or Shipment	2-108

SECTION I. REPAIR PARTS, SPECIAL TOOLS; TEST, MEASUREMENT AND DIAGNOSTIC EQUIPMENT (TMDE); AND SUPPORT EQUIPMENT

2-1. Common Tools and Equipment. For authorized common tools and equipment, refer to the Modified Table of Organization and Equipment (MTOE) applicable to your organization.

2-2. Special Tools, TMDE, and Support Equipment . Special tools; testing, measurement, and diagnostic equipment; and support equipment requirements are listed and illustrated in the Repair Parts and Special Tools List (RPSTL), TM 55-1905-223- 24P. These items are also listed in the Maintenance Allocation Chart (MAC), Appendix B of this manual.

2-3. Repair Parts. Repair parts are listed and illustrated in the Repair Parts and Special Tools List (RPSTL), TM 55-1905-223-24P.

SECTION II. SERVICE UPON RECEIPT

2-4. Checking Unpacked Equipment.

- a. Inspect the equipment for damage incurred during shipment. If the equipment has been damaged, report the damage in accordance with the instructions of DA Pam 738-750.
- b. Check the equipment against the packing slip to see if the shipment is complete. Report all discrepancies in accordance with the instructions of DA Pam 738-750.
- c. Check to see whether the equipment has been modified.

2-5. Deprocessing Unpacked Equipment.

- a. Remove protective caps, plugs, inserts, wrappings, and tape when inspection/inventory is completed. Inspect piping openings for damage. Wipe off dirt, grease, or protective films at time of installation.
- b. Remove chocks for resilient mounted components.

2-6. Initial Setup Procedure. Includes operational checks and inspections not performed for a routine startup. Direct support maintenance personnel will perform initial setup in accordance with the operator's manual, TM 55-1905-223-10.

2-7. Normal Startup. Refer to the operator's manual, TM 55-1905-223-10.

2-8. Shutdown Procedure (Usual or Unusual). Refer to the operator's manual, TM 55-1905-223-10.

2-9. Preliminary Servicing and Adjustment. To make sure that the HVAC equipment will be adequately inspected, serviced, and operationally tested before it is subjected to normal everyday use, the following pre-inspections, service, startup, and shutdown procedures must be performed. Refer to TM 55-1905-223-10 for the locations and operation of external controls and thermostats.

a. Heating.

(1) Duct Heaters (DH).

(a) Pre-inspection and service.

WARNING

Turn electrical power OFF to avoid personal injury.

- 1 Make sure all electrical power to the heater is OFF. Open terminal box door.
- 2 Visually check for dirt and debris in terminal box. Clean with soft bristle brush or vacuum cleaner with non-metallic nozzle as required.
- 3 Check all electrical connections for looseness and secure as required. Close terminal box door.
- 4 Inspect supply air fan to the heater. Refer to step b. of this procedure.
- 5 Check supply air intakes to heater for obstructions. Correct or remove obstruction as required.

- 6 Check exhaust grilles from heater to compartments for obstructions or buildup of dirt or debris. Remove obstructions as required. Clean grilles with soft bristle brush or vacuum cleaner.
 - 7 Check filters in recirculation air source. Make sure filters are clean and properly in place. Re-position or replace air filters as required. Refer to step c. of this procedure.
 - 8 Turn electrical power ON and start the unit.
- (b) Startup and operational check.
- 1 Make sure electrical power is ON at the primary breaker to the heater and to the supply air fan for the heater.
 - 2 Turn heater ON. Set thermostat to a higher setting than the ambient compartment temperature. Make sure thermostat is set to HEAT mode (TM 55-1905-223-10).
 - 3 When the heater has started, check for warm air flow at the heating duct outlet grille. If there is no air flow, or no warm air, turn the heater OFF and refer to Troubleshooting, Table 2-2. Locate the problem and correct as required.
- (c) Shutdown.
- 1 Turn thermostat/switch OFF (TM 55-1905-223-10).
 - 2 Turn primary circuit breaker to the heater OFF. Tag the breaker if it is being secured for a maintenance function.
- (2) Unit Space Heaters (UH).
- (a) Pre-inspection and service.

WARNING

Turn electrical power OFF to avoid personal injury.

- 1 Make sure all electrical power is OFF at the primary breaker to the heater.
- 2 Check heater air inlets and outlets for obstructions or buildup of dirt and debris. Remove obstructions as required. Clean with soft bristle brush or vacuum cleaner.
- 3 Check all electrical connections for looseness and secure as required.
- 4 Turn electrical power ON to the heater. Start the unit.

- (b) Startup and operational check.
 - 1 Turn electrical power ON at the circuit breaker to the unit.
 - 2 Turn the selector switch on the heater to ON. Set the thermostat to a higher setting than the ambient compartment temperature.

NOTE

The maximum ambient temperature at which the unit type heater can be operated is 80°F.

- 3 When the heater has started, listen for noise and check for warm air flow. If noise is heard, or there is no warm air, or no air flow, turn heater OFF.
- 4 Turn the primary breaker to the unit OFF.
- 5 Refer to Troubleshooting, Table 2-2, locate the problem and correct as required.
- (c) Shutdown.
 - 1 Turn the selector switch on the heater OFF.
 - 2 Turn electrical power OFF at primary breaker to heater. Tag breaker if it is being secured for a maintenance function.
- (3) Convection space heaters (CH). The procedures for pre-inspections, service, startup, and shutdown are the same as those for unit space heaters. Refer to paragraph a.(2) of this procedure.
- b. Ventilation/Supply Fans (SF) and Exhaust Fans (EF).
 - (1) Pre-inspection and service.

WARNING

Turn electrical power OFF to avoid personal injury.

- (a) Turn electrical power OFF at primary breaker to the fan. Turn manual switch/controller OFF.
- (b) Check fan impeller and motor for buildup of dirt and debris. Clean with soft brush, rag, or vacuum cleaner as required.
- (c) Check impeller setscrew for looseness and secure firmly.
- (d) Make sure the impeller blades are not touching the housing.

- (e) Check V-belt drives for proper alignment and belt tension (paragraphs 2-24 through 2-31).
 - (f) Check all electrical connections for looseness and secure as required.
 - (g) Check air inlets and outlets for obstructions. Remove obstructions as required.
 - (h) Turn electrical power ON. Start fan and check operation.
- (2) Startup and operational check.
- (a) Turn power ON to the fan at primary circuit breaker.
 - (b) Turn manual fan switch/controller ON.
 - (c) When fan has started, check supply air inlet and exhaust air outlet for air flow. Listen for noise or vibration. If there is no air flow, or noise and vibration exist, turn fan OFF.
 - (d) Turn primary breaker to fan OFF.
 - (e) Refer to Troubleshooting, Table 2-2, locate problem and correct as required.
- (3) Shutdown.
- (a) Turn manual fan switch/controller OFF.
 - (b) Turn primary circuit breaker to fan OFF. Tag breaker if it is being secured for a maintenance function.
- c. Cooling/Air Conditioning (A/C).
- (1) 3-ton self-contained units (Pilothouse, A/C-1; and Engine Control Room, A/C-3).
- (a) Pre-inspection and service.
- 1 Check air filters to make sure they are clean and properly positioned in the unit (paragraph 2-32). Clean supply and return air grilles.

WARNING

Turn electrical power OFF to avoid personal injury.

- 2 Turn electrical power OFF to the unit and check electrical connections for looseness. Secure as required.

- 3 Make sure blower motor, fan and other internal parts are free of dust and dirt. Clean with soft bristle brush and vacuum cleaner with a non-metallic nozzle.
 - 4 Open discharge and suction service valves on the compressor.
 - 5 Make sure external seawater inlet and outlet valves are open.
 - 6 Make sure external seawater strainer is clean (TM 55-1905-223-24-18).
 - 7 Make sure no electrical components are wet and that panels are closed before turning power ON to the unit.
 - 8 Turn electrical power ON to the unit. Run the unit and conduct operational check.
- (b) Startup and operational check.
- 1 Set thermostat to COOLING position. Set the clear dial on the thermostat to the desired temperature. The red dial is the room temperature indicator.

NOTE

The fan will run continuously if the fan switch is set to ON.

- 2 Make sure the thermostat is set to a lower setting than the ambient room temperature as indicated on the red dial.
- 3 Adjust discharge outlets for desired air flow direction.
- 4 When the unit has started, run the unit for 5 to 10 minutes. Check the entering air temperature at the filter with a thermometer. Also check the leaving air temperature at the discharge duct. There should be a 15 to 20 degree difference in the two temperatures. If not, refer to Troubleshooting, Table 2-2.
- 5 While the unit is running, listen for noise or vibration. Correct as required (Troubleshooting, Table 2-2).
- 6 Make sure any water collected in the condensate drain pan is draining properly.
- 7 Visually check and make sure the condenser seawater is properly discharging overboard.

NOTE

After an air conditioner has been OFF for an extended period of time, it may take several hours for the unit to reach maximum cooling performance. This is especially true in high ambient temperatures.

- 8 Operating suction (low side) and discharge (high side) pressures have to be checked with portable manifold gauges. Check these pressures only when required as a troubleshooting function.
- (c) Shutdown.
- 1 Set thermostat to OFF.
 - 2 Turn primary circuit breaker to the air conditioner OFF. Tag the circuit breaker if it is being secured for maintenance functions.
- (2) 16-ton unit (Accommodations, A/C-2).

CAUTION

If the Accommodation Unit's (A/C-2) main power breaker, or disconnect switch, has been turned OFF for over 4 hours, the unit's HEAT/OFF/COOL manual switch on thermostat must remain OFF for a period of 5 hours after turning main power breaker, or disconnect, ON. This energizes the compressor crankcase heater and allows the oil time to re-heat.

- (a) Pre-inspection and service.
- 1 Check air filters to make sure they are clean and properly in place. Correct or replace filters as required (paragraph 2-33).
 - 2 Clean all supply and return air grilles of dust and debris.

WARNING

Turn electrical power OFF to avoid personal injury.

- 3 Check electrical connections for loose. Secure as required.
- 4 Check V-belt on blower for looseness and proper alignment. Secure or align as required (paragraph 2-34).
- 5 Make sure external seawater strainer is clean (TM 55-1905-223-24-18).
- 6 Make sure seawater inlet and outlet valves are open.
- 7 Make sure discharge and suction service valves are open.

WARNING

Do not open crankcase until compressor has been isolated and purged of refrigerant charge.

- 8 Check oil level in compressor observation window. The level must be near the half-way point in the window. Add or remove compressor oil as required to bring the oil to the half-way level (Item 5, PMCS Table 2-1).
 - 9 Check moisture indicator in refrigerant line to make sure there is no moisture in the system. The indicator will be GREEN if the system is dry and YELLOW if wet. If a wet condition exists, the system must be purged, evacuated, and recharged with R-22 (Item 9, Table 2-2).
 - 10 Make sure that no electrical components are wet for any reason. Locate the problem and correct as required before turning power ON to the unit.
 - 11 Close all cabinet and terminal box panels before starting unit.
 - 12 Check thermostats to make sure the selector is in the COOL position. Set all thermostats to their lowest (coldest) setting for operational checks.
 - 13 Turn electrical power ON, start the unit, and conduct operational check.
- (b) Startup and operational check.

- 1 Turn electrical power ON at the primary circuit breaker to the unit.
- 2 Make sure the external seawater pump is ON. Visually check to see that condenser seawater is properly discharging overboard.
- 3 Turn the compressor control and fan switches in the terminal box to the ON position.
- 4 Run the unit for 5 minutes and visually check the refrigerant flow sight glass. After the compressor has run for 5 minutes, a foggy or bubbling liquid in the refrigerant line sight glass indicates a shortage of refrigerant. Add R-22 as required.

CAUTION

Do not add refrigerant if the sight glass is clear.

- 5 Check the discharge and return air temperatures. There should be a 15 to 25 degree difference in the two temperatures. If not, refer to Troubleshooting, Table 2-2.

NOTE

After an air conditioner has been OFF for an extended period of time, it may take several hours for the unit to reach maximum cooling performance. This is especially true in high ambient temperatures.

- 6 While the unit is running, listen for excessive noise or vibration. Locate and correct as required (Troubleshooting, Table 2-2).
 - 7 After the unit has run for 30 minutes, check the operating suction (low side) and discharge (high side) pressures on the fixed manifold gauges in the system. Operating pressures for the suction (low side) of the system must not exceed 85 psig nor drop below 50 psig. The 55 psig to 72 psig range is normal. The discharge (high side) of the system must not exceed 300 psig nor drop below 170 psig. The 170 psig to 230 psig range is normal. If pressures are not within their normal ranges, refer to Troubleshooting, Table 2-2, locate the problem, and correct as required.
 - 8 Adjust the water regulating valve in seawater discharge line to 210 psig (discharge head pressure) by loosening locknut and turning adjusting screw.
 - 9 When all operational checks have been made, return all thermostats to their desired temperature settings.
- (c) Shutdown.
- 1 Turn all thermostats to OFF.
 - 2 Turn compressor control switch OFF in the terminal box.
 - 3 Turn primary circuit breaker to the unit OFF. Tag the breaker if it being secured for a maintenance function.

SECTION III. UNIT PREVENTIVE MAINTENANCE CHECKS AND SERVICES (PMCS)

- 2-10. Explanation of PMCS Table.** PMCS is designed to keep the equipment in good working condition. This is accomplished by performing certain tests, inspections, and services. Table 2-1 lists items to be serviced and the procedures needed to accomplish the PMCS. The "Interval" column tells you when to perform a check or service. If needed, PMCS may be performed more frequently than the indicated interval. The "Procedures" column tells you how to perform the required checks and services. If your equipment does not perform as required, see Table 2-2, Troubleshooting. Report any malfunctions or failures on DA Form 2404. In the Item Number column on DA Form 2404, record the appropriate Item Number from the PMCS table.

Table 2-1. Preventive Maintenance Checks and Services (PMCS)
D - Daily M - Monthly B - Bimonthly S - Semiannually A - Annually

Item No.	Intervals					Items To Be Inspected/Service	Procedures
	D	M	B	S	A		
1	•					Filters in airflow sources (A/C-1, 2, and 3)	Visually check for buildup of dirt and debris. Replace filter as necessary (paras. 2-32 or 2-33). Make sure that all air flow intakes and outlets are clear of blockage or obstruction. Move obstructions as required for free air flow. Visually check the high (discharge) and low (suction) pressures on the fixed manifold gauges (compressor running) located on the lower portion of the unit. The high pressure should be between 170 and 230 psig. The low pressure should be between 58 and 72 psig. If pressures are not within this range, refer to Table 2-2, Troubleshooting. NOTE There are no fixed manifold gauges for observing operating pressures on A/C-1 and 3 (self-contained units). Pressures are checked on these units with portable gauge manifold as a troubleshooting function only.
2	•					All air flow intakes and outlets	
3	•					Operating pressures on A/C-2; accommodations	
4	•					All unit and convection heaters	

Visually check for buildup of dirt or debris on exterior of heater surfaces.

WARNING
Turn electrical power off.

Turn electrical power to the heater off and clean with rags, soft brush, or vacuum cleaner.

Table 2-1. Preventive Maintenance Checks and Services (PMCS) - CONT
D - Daily M - Monthly B - Bimonthly S - Semiannually A - Annually

Item No.	Intervals					Items To Be Inspected/Service	Procedures
	D	M	B	S	A		
5	•					Compressor on air conditioner No. 2 (accommodations)	<p align="center"><u>WARNING</u></p> <p align="center">Do not open crankcase until system has been conditioner No. 2 pumped down.</p> <p>Visually check the oil level by viewing the sight glass in the compressor crankcase. Shut down the compressor and allow oil to settle for 5 minutes before checking. The oil level should be near the halfway point in the sight glass. Pump system down (Item 10, Table 4-1). Remove fill plug from crankcase and add clean compressor oil as required. Replace fill plug. To remove excess oil, open crankcase drain plug only a few turns until oil seeps from around threads in plug. Do not fully remove plug. When oil is at proper level, tighten drain plug to 18 ft-lb. Refer to LO 55-1905-223-12.</p> <p align="center"><u>NOTE</u></p> <p align="center">Oil level cannot be observed in A/C-1 and 3 (self-contained units).</p> <p>Open valves and allow refrigerant back into system (Item 10, Table 2-2).</p> <p>Visually check all V-belts for proper tension and alignment. Check for cracked or deteriorated belts. Adjust, secure, or replace V-belt as required (paras. 2-24, 2-27, and 2-30).</p>
6		•				All fan motors with V-belt drive (SF-4 and 6, EF-4, and 6, A/C-2)	

■ Table 2-1. Preventive Maintenance Checks and Services (PMCS) - CONT

D - Daily M - Monthly B - Bimonthly S - Semiannually A - Annually

Item No.	Intervals					Items To Be Inspected/Service	Procedures
	D	M	B	S	A		
7		●				All fans and motors (SF, EF, and A/C)	<p><u>WARNING</u></p> <p>Turn off electrical power.</p> <p>Secure the electrical power and check fan blades and motors for buildup of dirt and debris. Clean as required with rags, soft brush, or vacuum cleaner with non-metallic nozzle.</p> <p>Verify that objects are not placed in front of fans. Ensure that the intake and exhaust sides of all fans are free from obstructions.</p>
8		●				Air conditioners (A/C-1, 2, and 3)	<p><u>WARNING</u></p> <p>Secure the electrical power and remove dirt and debris from the exterior of the unit.</p> <p>Check for buildup of dirt and debris on compressor, condenser, and other external cabinet components.</p> <p>Clean with rags, soft brush, or vacuum cleaner with non-metallic nozzle.</p>

Table 2-1. Preventive Maintenance Checks and Services (PMCS) - CONT

D - Daily M - Monthly B - Bimonthly S - Semiannually A - Annually

Item No.	Intervals					Items To Be Inspected/Service	Procedures
	D	M	B	S	A		
9			●			Seawater condensers (A/C-1, 2, and 3)	Clean seawater strainer (TM 55-1905-223-24-18).
10				●		All ventilation fans (SF and EF) and A/C-2 blower motor	<p><u>WARNING</u></p> <p>Turn electrical power off.</p> <p>Secure electrical power and lubricate the fan bearings with one or two shots from a general purpose grease gun. Refer to LO 55-1905-223-12.</p>
11			●			Self-contained air conditioner fan motors (A/C-1 and 3)	<p><u>WARNING</u></p> <p>Turn electrical power off.</p> <p>Secure electrical power and lubricate the fan bearings with six to eight drops of 20W oil applied into the ports on the motor.</p>
12				●		All heaters (DH, UH, and CH)	<p><u>WARNING</u></p> <p>Turn electrical power off.</p> <p>Secure electrical power to the heater and check all electrical connections for looseness. Secure as required.</p>

Table 2-1. Preventive Maintenance Checks and Services (PMCS) - CONT
D - Daily M - Monthly B - Bimonthly S - Semiannually A - Annually

Item No.	Intervals					Items To Be Inspected/Service	Procedures
	D	M	B	S	A		
13		.	•			All ventilation fan motors (SF and EF)	<p><u>WARNING</u></p> <p>Turn electrical power OFF.</p> <p>Secure electrical power and lubricate bearings with one or two shots from a general purpose grease gun. Refer to LO 55-1905-223-12.</p>
14					•	All ventilation fan assemblies (SF and EF)	<p><u>WARNING</u></p> <p>Turn electrical power OFF.</p> <p>Secure electrical power and check all mounting hardware for looseness. Secure all bolts, nuts, and screws until snug.</p> <p>Check all electrical connections for looseness. Secure as required.</p>
15					•	All V-belt drive pulleys (SF-4 and 6, EF-4 and 6, A/C-2)	<p><u>WARNING</u></p> <p>Turn electrical power OFF.</p> <p>Secure electrical power. Remove V-belt and inspect pulley sheave for burrs, chips, or cracks. Replace pulley as required. Check for dirt, oil, rust, or other foreign matter in the pulley groove. Remove rust with a hard wire brush. Clean with rag and soapy water.</p>

Table 2-1. Preventive Maintenance Checks and Services (PMCS) - CONT
D - Daily M - Monthly B - Bimonthly S - Semiannually A - Annually

Item No.	Intervals					Items To Be Inspected/Serviced	Procedures
	D	M	B	S	A		
16					<ul style="list-style-type: none"> All air conditioner cooling coils/evaporators. (A/C-1, 2, and 3) - continued 	<p style="text-align: center;"><u>CAUTION</u></p> <p style="text-align: center;">Do not bend metal fins or coil assembly will be damaged.</p> <p>Clean buildup of dust and debris from the surface of the coil with a soft bristle brush.</p> <p style="text-align: center;"><u>WARNING</u></p> <p style="text-align: center;">Compressed Air Hazard. Make sure air pressure is below 30 psi, or damage to eyes and skin could occur.</p> <p>Compressed air of less than 30 psi may be used to further remove dust and debris from the air passages through the coil.</p> <p>Replace filters and close cabinet panel or door.</p>	

SECTION IV. UNIT MAINTENANCE TROUBLESHOOTING

2-11. Symptom Index. Both a symptom index and a troubleshooting table are provided. The symptom index will help you locate the information you need for troubleshooting.

SYMPTOM INDEX		Troubleshooting Procedure (Table 2-2)
HEATING		
No heat - blower running		Item 2
No heat - no blower		Item 1
Not enough heat		Item 3
VENTILATION (FANS)		
Air flow too high		Item 6
Air flow too low		Item 5
Excessive noise or vibration		Item 4
Fan does not operate		Item 7
AIR CONDITIONING		
Cold or frosted liquid line (or line component)		Item 14
Compressor crankcase cold (sweating or frosting)		Item 11
Compressor noises		Item 20
Compressor or compressor motor hums but does not start		Item 16
Compressor runs continuously		Item 19
Compressor short cycles on high pressure cut-out		Item 17
Compressor short cycles on low pressure cut-out		Item 18
Compressor will not start		Item 15
High crankcase temperature (compressor extremely hot)		Item 12
High operating head (discharge) pressure		Item 8
High suction pressure		Item 10
Hot liquid line		Item 13
Low operating head (discharge) pressure		Item 9
No cooling - blower does not run		Item 22
No cooling - blower running		Item 23
Partial or insufficient cooling - blower running		Item 24
Piping rattles		Item 21
Water leaking from the unit		Item 25
ALL HVAC EQUIPMENT		
Contactor chatter		Item 27
Unit gives electrical shock		Item 26

2-12. Troubleshooting. Table 2-2 lists the common fault conditions that may be found during operation or maintenance of the equipment. Look for causes and do corrective actions in the order listed. This manual cannot list every symptom that may show up, and it cannot list all of the possible causes and corrective actions. If a symptom is not listed, or if it keeps up after you have performed the corrective actions, notify your supervisor.

Table 2-2. Troubleshooting

Malfunction	Test or Inspection	Corrective Action
--------------------	---------------------------	--------------------------

HEATING

1. No heat - no blower running
 - STEP 1. Check for power switch OFF or thermostat not properly set.
Turn power switch ON. Set thermostat to required temperature.
 - STEP 2. Check for circuit breaker tripped.
Reset breaker. If breaker trips again, check for defective contactor or fan control.
 - STEP 3. Check for blown fuse in fused heaters.
Replace as required (paragraph 2-17).
 - STEP 4. Check for defective contactor, transformer, or thermostatic switch.
Secure electrical connections as required. Repair broken wires. Replace defective contactor, transformer, or switch as required (paragraph 2-17).
 - STEP 5. Check for defective fan.
Replace or repair as required.
 - STEP 6. Check for defective heater motor on unit space heaters.
Replace heater motor as required (paragraphs 2-22 and 2-23).

2. No heat - fan/blower running.
 - STEP 1. Check for proper thermostat setting.
Set to required temperature.

3. Not enough heat.
 - STEP 1. Check to see if thermostat is set too low.
Set to required temperature.

WARNING

Shock hazard. Wear insulated gloves.

Table 2-2. Troubleshooting - CONT

Malfunction	Test or Inspection	Corrective Action
-------------	--------------------	-------------------

HEATING - CONT

- STEP 2. Check for low voltage to heater,
Be sure power supply is the proper voltage for the individual heater. Refer to Tables 1-1 thru 1-3 for proper voltage ratings.
- STEP 3. Check filter in air flow source.
Replace as required.
- STEP 4. Check for proper air flow to heater.
Correct as required.
- STEP 5. Check for element failure.
 - a. Clean and secure connections.
 - b. Replace element (appropriate paragraphs 2-17 thru 2-23).

VENTILATION (SUPPLY AND EXHAUST FANS)

WARNING

Make sure a fan is not in a stalled condition before attempting maintenance. Severe injury could result if fan operates while being worked on.

- 4. Excessive noise or vibration.
 - STEP 1. Check for accumulation of dirt or debris on impeller (fan blades).
Clean impeller with rags, soft bristle brush, or vacuum cleaner.
 - STEP 2. Check to see if belt is too loose or too tight on V-belt drive fans.
Adjust as required (paragraph 2-25, 2-28, or 2-31).
 - STEP 3. Check for belt hitting guard on V-belt drive fans.
Adjust as required (paragraph 2-25, 2-28, or 2-31).
 - STEP 4. Check to see if belt is dirty, oily, or frayed on V-belt drive fans.
 - a. Clean dirty or oily belt with mild soap and water.
 - b. Replace frayed belt (paragraph 2-25, 2-28, or 2-31).
 - STEP 5. Check for wrong belt in use on V-belt drive fans.
Replace as required (paragraph 2-25, 2-28, or 2-31).

Table 2-2. Troubleshooting - CONT

Malfunction	Test or Inspection	Corrective Action
-------------	--------------------	-------------------

VENTILATION (SUPPLY AND EXHAUST FANS) - CONT

- | | | |
|----------|---|--|
| STEP 6. | Check for loose mounting bolts or other attached hardware.
Secure bolts and hardware until snug. | |
| STEP 7. | Motor or drive misalignment.
Check and adjust motor as required. (Refer to paragraph 2-25, 2-28, or 2-31.) | |
| STEP 8. | Check to see if impeller is hitting housing.
a. Adjust impeller on shaft.
b. Replace impeller, shaft, or fan as required. (Refer to paragraph 2-25, 2-28, or 2-31.) | |
| STEP 9. | Check impeller and sheaves for looseness.
Secure mounting hardware as required. | |
| STEP 10. | Check for bent drive shaft
Replace fan shaft or motor as required. (Refer to paragraph 2-28, or 2-31.) | |
| STEP 11. | Check to see if bearings need lubrication.
Lubricate bearings (PMCS Table 2-1). | |
| STEP 12. | Check for worn or defective bearings.
Replace bearings as required (appropriate paragraph 2-25 thru 2-32). | |
| 5. | Air flow too low. | |
| STEP 1. | Check for dirty or clogged filter in air flow source.
Replace as required (paragraph 2-33 or 2-34). | |
| STEP 2. | Check to see if dampers or registers are closed.
Open dampers or registers as required (TM 55-1905-223-10). | |
| STEP 3. | Check to see if inlet or outlet screens are clogged or obstructed.
Clean screens or clear obstructions as required (TM 55-1905-223-10). | |
| STEP 4. | Check for dirty or clogged coil in recirculation air source.
Clean as required (PMCS Table 2-1). | |
| 6. | Air flow too high. | |
| STEP 1. | Check air filters to ensure that they are in place in recirculation air source (A/C-1, 2, and 3).
Insert or adjust filters (paragraph 2-33 or 2-34). | |

Table 2-2. Troubleshooting - CONT

Malfunction	Test or Inspection	Corrective Action
-------------	--------------------	-------------------

VENTILATION (SUPPLY AND EXHAUST FANS) - CONT

- STEP 2. Check to see that registers, grilles and dampers are installed. Install or adjust (TM 55-1905-223-24-18).

- 7. Fan does not operate.
 - STEP 1. Check to see if electrical power to the fan is OFF. Turn power ON.

 - STEP 2. Check for open circuit breakers. Reset circuit breaker. If it trips again, locate the problem and correct as required (TM 55-1905-223-10 and TM 55-1905-223-24-18).

 - STEP 3. Check for broken or loose wiring and connections. Check wiring and connections. Secure or replace as required.

 - STEP 4. Check for broken V-belt on belt drive fans. Replace as required (paragraph 2-25, 2-28, or 2-31).

 - STEP 5. Check for loose pulley on belt drive fan. Check pulley. Secure setscrew until snug (paragraph 2-25, 2-28, or 2-31).

 - STEP 6. Check to see if voltage is wrong. Refer to Table 1-4 or 1-5 for proper voltage rating (paragraph 2-17).

 - STEP 7. Check for defective fan motor. Replace fan motor (appropriate paragraph 2-25 thru 2-32).

AIR CONDITIONING

- 8. High operating head (discharge) pressure above normal.
 - STEP 1. Check to see if compressor discharge stop valve partially closed (A/C-2; accommodations). Turn valve fully counterclockwise.

 - STEP 2. Check to see if seawater pump is running and water is flowing through condenser.
 - a. Replace the seawater pump if defective (TM 55-1905-223-24-18).
 - b. Open hand valves, if closed (TM 55-1905-223-24-18).
 - c. Clean sea chest strainer as required (TM 55-1905-223-24-18).
 - d. Clear obstruction in supply lines as required (TM 55-1905-223-10).

Table 2-2. Troubleshooting - CONT

Malfunction	Test or Inspection	Corrective Action
AIR CONDITIONING - CONT		
	STEP 3.	Check to see if condenser water inlet temperature is above 900F. Make sure the water intake line is clear of hot water discharges or other external sources of heat.
9.	Low operating head (discharge) pressure below normal.	
	STEP 1.	Check to see if water inlet temperature is too low. Adjust water flow by adjusting the water regulating valve to 210 psig (discharge/head pressure) (A/C-2). (Valve is automatically adjusted on self-contained units.)
	STEP 2.	Check for excessive water flow through condenser. Adjust the water regulating valve in seawater discharge line to 210 psig on A/C-2 by loosening the locknut and turning the adjusting screw.
	STEP 3.	Check to see if compressor suction stop valve is partially closed (A/C-2; accommodations). Open valve fully counterclockwise.
10.	Higher than normal suction pressure.	
	STEP 1.	Check for over-feeding of refrigerant in expansion valve equipped unit (A/C-2). Make sure thermal bulb on expansion valve is firmly secured to the refrigerant line.
11.	Compressor crank-case cold (sweating or frosting).	
	STEP 1.	Check to see if operating thermostat is set too low or is defective. Adjust thermostat.

WARNING

Do not open crankcase until compressor has been isolated and refrigerant charge removed.

- STEP 2. Check for too much oil in system (A/C-2 only).
Remove excess oil. Adjust level to the half-way point in the observation window (sight glass) on compressor (Item 5, Table 2-1).
- STEP 3. Check for expansion valve (on valve-equipped unit; A/C-2).
Check to see that the thermal bulb of the expansion valve is firmly attached in place.

Table 2-2. Troubleshooting - CONT

Malfunction	Test or Inspection	Corrective Action
AIR CONDITIONING - CONT		
12.	High crankcase temperature (compressor extremely hot).	
WARNING		
Shock Hazard. Wear protective gloves when checking voltage.		
	STEP 1. Check for low voltage or dirty electrical contacts in contactor.	
	a. Check voltage to the unit (paragraph 2-15). Refer to Table 1-6 for voltage rating.	
	b. Clean dirt or oil from contact points with soft rag.	
	c. Replace contactor if points are burned or pitted.	
13.	Extremely hot liquid line.	
	STEP 1. Check for high operating head (discharge) pressure (A/C-2). Refer to Item 8 of this table.	
14.	Cold or frosted liquid line (or component in the liquid line).	
	STEP 1. Check for low operating head (discharge) pressure (A/C-2). Refer to Item 9 of this table.	
15.	Compressor will not start.	
	STEP 1. Check to see if power is OFF or operating thermostat set too high. Check main switch and thermostat. Turn power ON or set thermostat to lower setting as required.	
	STEP 2. Check to see if control circuit breaker is OFF or tripped. Reset circuit breaker. If it keeps tripping, check the control circuit for a short and correct as required.	
WARNING		
Turn electrical power OFF.		
	STEP 3. Check for loose electrical connections or faulty wiring.	
	a. Make sure all electrical connections are tight.	
	b. Check for burned or broken wiring. Correct as required.	

Table 2-2. Troubleshooting - CONT

Malfunction	Test or Inspection	Corrective Action
-------------	--------------------	-------------------

AIR CONDITIONING - CONT

WARNING

Shock Hazard. Wear protective gloves when checking voltage.

- STEP 4. Check for overload trip due to low voltage. Check voltage to the unit (paragraph 2-17). Find and correct cause of low voltage (TM 55-1905-223-24-18).

WARNING

Turn power OFF.

- STEP 5. Check for dirty electrical control contacts on the thermostat or defective thermostat. Clean contacts with soft bristle brush as required. If contacts are burned or pitted, replace the thermostat. (Refer to TM 55-1905-223-10 for location and operation of thermostats.)
 - STEP 6. Check to see if high pressure control switch is open due to high head (discharge) pressure. Locate and correct the cause of high head pressure. Refer to Item 8 of this table.
 - STEP 7. Check for open contact on internal overload protector in compressor (A/C-1 and 3). Allow time for compressor to cool and automatically reset. If it does not reset when cooled down, check for "open" or "short" in compressor (paragraph 2-17).
 - STEP 8. Check for defective compressor or compressor motor. Test compressor or compressor motor for a "short" or "open" condition (paragraph 2-17).
16. Compressor or compressor motor hums but does not start.
- STEP 1. Check for broken wiring. Visually check for broken wire correct as required.
 - STEP 2. Check for pitted or burned contacts in circuit breaker or defective circuit breaker.

Table 2-2. Troubleshooting - CONT

Malfunction	Test or Inspection	Corrective Action
AIR CONDITIONING - CONT		
	a.	Check points in breaker. Clean dirt or oil from points with soft rag or soft brush.
	b.	Replace circuit breaker if contacts are burned or pitted (TM 55-1905-223-24-18).
	STEP 3.	Check to see if compressor motor is defective. Replace compressor if "short" or "open" in windings (paragraph 2-15).
17.		Compressor short cycles on high pressure cut-out.
	STEP 1.	Check water pressure (if it drops below 150 psig) through condenser or clogged condenser.
	a.	Adjust water regulating valve (A/C-2; accommodations) to 210 psig (discharge/head pressure).
	b.	Make sure all water line valves are fully open (TM 55-1905-223-10).
	c.	Check for clogged sea strainer (TM 55-1905-223-24-18).
	d.	Make sure seawater pump is operating properly (TM 55-1905-223-24-18).
	STEP 2.	Check to see if compressor discharge stop service valve is partially closed (A/C-2; accommodations). Turn valve fully (counterclockwise).
	STEP 3.	Check to see if seawater inlet temperature to condenser is warm (above 90°F). System is designed for maximum of 90 ° F inlet water temperature. Ensure water intake line is clear of hot water discharge or other external sources of heat.
18.		Compressor short cycles on low pressure cut-out. Recharge system with R-22 (Item 12, Table 2-2).
	STEP 1.	Check to see if suction stop (service) valve is partially closed (A/C-2; accommodations). Open valve fully counterclockwise.
19.		Compressor runs continuously.
	STEP 1.	Check to see if control contacts are fused together. Locate control and replace as required.

Table 2-2. Troubleshooting - CONT

Malfunction	Test or Inspection	Corrective Action
AIR CONDITIONING - CONT		
20.	Compressor makes noises.	
	STEP 1.	Check for loose mounting bolts. Secure all mounting bolts until snug.
	STEP 2.	Check for slugging due to refrigerant floodback (on expansion valve equipped unit; A/C-2; accommodations). Make sure the thermal bulb on the expansion valve is firmly attached to the suction line. Correct as required.
	STEP 3.	Check for hydraulic knock due to excess oil in circulation. Refer to Item 11 of this table.
21.	Piping rattles.	
	STEP 1.	Check for improper or loose supports. Correct as required.
22.	No cooling - blower does not run.	
	STEP 1.	Check to see if fan switch is in OFF position. Turn switch ON.
	STEP 2.	Check to see if circuit breaker OFF or tripped. a. Re-set breaker. If breaker trips again, locate the problem and correct as required. b. Check for defective circuit breaker and replace as required (TM 55-1905-223-24-18).
	STEP 3.	Check for defective wiring, compressor, or electrical components. Refer to Item 15 of this table.
23.	No cooling - blower running.	
	STEP 1.	Check to see if thermostat is set to FAN ON, but selector switch set to OFF. Set HEAT-OFF-COOL switch on thermostat to COOL.
	STEP 2.	Check to see if thermostat is set too high. Adjust thermostat to a lower temperature setting.
	STEP 3.	Check for defective thermostat. Replace thermostat (TM 55-1905-223-24-18).

Table 2-2. Troubleshooting-CONT

MALFUNCTION	TEST OR INSPECTION	CORRECTIVE ACTION
-------------	--------------------	-------------------

AIR CONDITIONING-CONT

- STEP 4. Check for high head (discharge pressure).
Refer to Item 8 of this table.
- STEP 5. Check for defective compressor.
Refer to Item 15 of this table.
- 24. Partial or insufficient cooling-blower running.
 - STEP 1. Check to see if thermostat is set too high.
Adjust thermostat to a lower temperature setting.
 - STEP 2. Check for dirty air filter.
Replace as required (paragraph 2-33 or 2-34).
 - STEP 3. Check for defective fan/blower.
Refer to Item 5 of this table.
 - STEP 4. Check for insufficient air flow through cooling coil (evaporator).
Clean dirt from coil.
 - STEP 5. Check for high head (discharge) pressure.
Refer to Item 8 of this table.
 - STEP 6. Check to see if electric heat element is ON in a duct heater.
Check for defective heat contactor. Replace as required (appropriate paragraph 2-18 thru 2-22).
- 25. Water leaking from unit.
 - STEP 1. Check for loose water line or drain connection or hole in line.
Correct as required.

ALL HVAC EQUIPMENT

- 26. Unit gives electrical shock.
 - STEP 1. Check for grounded electrical circuit.
Check equipment and wiring to determine what is grounded. Repair or replace the equipment as required.

Table 2-2. Troubleshooting-CONT

MALFUNCTION	TEST OR INSPECTION	CORRECTIVE ACTION
AIR CONDITIONING-CONT		
27.	Contactor chatter.	<p>STEP 1. Check for loose wiring or connections. Secure as required.</p> <p>STEP 2. Check for proper voltage. If low voltage, check voltage to contactor (paragraph 2-17).</p> <p>STEP 3. Check for vibration or dirty thermostat contacts. Remove thermostat cover and clean with small soft bristle brush.</p>

2-13. Additional Troubleshooting Tips on HVAC Equipment . The following information is furnished to aid maintenance personnel when tracking down a problem with certain equipment in the HVAC subsystem.

a. Duct Heaters (DH).

(1) No Heat.

- (a) Check to see that the controlling thermostat is set to call for HEATING. Check fan switch to see that it is ON. If the fan runs, you have learned there is power to that section and that the fan relay and motor are apparently operating properly. Return the fan switch to the AUTO position and check the heater for the problem.
- (b) Check and determine that power and proper voltage are going to the heater.

WARNING

Turn power OFF when checking continuity of components.

- (c) With ALL HIGH VOLTAGE OFF, various components can be checked with an ohmmeter to determine if they are defective.
 - (d) Replace defective parts, but note the following:
 - 1 An open fusible link or manual reset is usually caused by a stuck contactor that allows a heater to run on after thermostat is satisfied and the fan goes off.
 - (e) Use the exact part or approved alternates when replacing non-functioning parts.
- (2) Not Enough Heat.
- (a) If proper voltage is going to the heater and heater components are apparently operating properly, use an ammeter and check the ampere draw of the heater. The amperage should be no more than 10 percent lower than the full amp rating on the heater data plate.
 - (b) A heater that cycles off before the thermostat is satisfied may cause complaints only during the coldest days when maximum performance is required.
 - (c) A thermostat with a defective heat anticipator or incorrect differential setting will short cycle a heater OFF before the set temperature is reached and when maximum running time may be required.

- (d) If the shortage of heat is only in some areas you might have a condition that requires seasonal damper adjustments to balance differing ratios of heat loss and heat gain. A galley may require proportionately more summer cooling than winter heating. Crushed or broken duct would affect a particular area. Also restricted air flow usually affects rooms at the end of the duct system.
 - (e) Turning on the heat after the area has gotten cold and expecting it to warm up quickly is a common complaint. Discharge air that has a low heat rise might feel, as it blows on a 980F hand or face, as though the system is not working properly or as though there is no heat at all.
- (3) Heater Cycling on Automatic Limit.
- (a) The possibility of a defective or wrong temperature limit switch is always there, but more often than not other conditions contribute to a heater cycling problem.
 - (b) Improper air flow caused by obstructions to return air, a loose or broken belt, or clogged filters and/or evaporator coil, may cause the limit switch to cycle the heater OFF before the thermostat is satisfied. This could cause a lack of heat in general, or just in the end-of-the-line rooms, because of the reduced pressure in the duct system.
 - (c) Uneven air flow over the entire heater. Heaters are designed not to nuisance-cycle, provided that a sufficient velocity of inlet air flows between the primary limit and heating element. Some other conditions that contribute to cycling of a heater are as follows:
 - 1 Heater too close to the blower outlet.
 - 2 Baffles bouncing air off heating element onto limit switch.
 - 3 Base of heater control box not flush with the air stream (reduces air curtain).
- (4) Open Secondary Protective Device.
- (a) An open manual reset, fusible link, or other secondary thermal device is usually the result of a stuck contactor where the thermostat is satisfied and there is no more fan. The heater runs on in this abnormal condition until the secondary device opens.
 - (b) Lack of proper air over the heater could cause enough cycling of the limit switch so that a secondary would open after a buildup of enough residual heat.
 - (c) Grounded heating element may generate enough heat without fan to open a secondary. Overcurrent fuses or circuit breakers may or may not open, depending on the amount of element resistance to ground and the amount of related current it draws.

(5) Element Failure.

- (a) Excessive overheating with wrong temperature or bypassed primary limit control.
- (b) Improper filtering so that elements can not dissipate heat through dirty covering.
- (c) Corroded hardware or loose connections causing burned-off wires or elements.
- (d) Any physical damage, ground, or nick in the element itself.

b. Axial Ventilating Fans.

- (1) Axial fans, as all fans, are sensitive to inlet and outlet conditions. Disturbances or obstructions of air intakes and discharges will not allow the normal velocity to develop, and will result in loss of performance.
- (2) The impeller (blades) in an axial flow fan must be kept reasonably clean if it is to perform properly. Supply air ventilating fans will seldom need cleaning. Exhaust air fans must be checked and cleaned as required. Dirt or deposits will usually build up on an impeller evenly, and they present no problem to performance or operation until they become thick enough to break away in crust-like pieces. When this happens, the impeller may be thrown out of balance and the resulting vibration could be serious. Any hard, dry layer of dirt and debris must be removed by solvent cleaning or scraping. Be careful not to cut or scrape through protective coatings or paint on the impeller blades. Removal of blade coatings, as well as wear from abrasion, can also cause excessive vibration which will lead to damage of the impeller and other fan components.
- (3) Electrical Connections.
 - (a) Electrical connections must be connected following electrical characteristics as indicated on the motor nameplate. The wiring diagram on the motor nameplate or terminal box must be strictly adhered to.
 - (b) Special attention should be given to being sure that a single phase motor is connected only to a single phase supply of proper voltage, and that a three phase motor will only operate on a three phase supply. Electric motors will burn out and fail immediately if improperly connected.
 - (c) The rotation of a motor and impeller must be in the same direction as indicated by the directional arrows on the unit. If the impeller is turning in the wrong direction, it will not deliver the rated airflow. The motor connections must immediately be altered to correct rotation.

(4) V-belt Drives.

- (a) A noisy V-belt indicates the need for attention. However, it is normal for belts to squeal slightly at startup. V-belt noise can be caused by the slapping of the belts against the drive guard or other obstruction. Check for an improperly installed guard, loose belts, buildup of foreign material in the sheave grooves, or excessive vibration. The cause of excessive vibration should be determined and corrected.
- (b) Ideal V-belt tension is the tension at which the belt will not slip under peak load conditions. Overtensioning shortens belt and bearing life. Belts should be free from foreign material which may cause slipping. Do not use belt dressings.
- (c) All sheaves' grooves must be smooth and uniform. Burrs and rough spots along the sheave rim can damage belts. Dust, oil, and other foreign matter can lead to pitting and rust, and should be avoided as much as possible. Badly worn grooves or a shiny groove bottom indicates that either the sheave, the belt, or both are badly worn. Sheaves that are not aligned properly cause excessive belt wear and sheave wear.

(5) Motor and Fan Bearings.

- (a) The most frequent cause of bearing failure is not greasing often enough, using an excessive quantity of grease, or using incompatible greases (LO 55-1905-223-12).
- (b) Excessive vibration, especially if the bearing is not rotating, will also cause bearings to fail. Bearings must also be protected from water and moisture to avoid internal corrosion.

c. Air Conditioners.

- (1) When it is necessary to remove or add oil to a compressor, remember the following:
 - (a) Never save compressor oil for re-use.
 - (b) Never add compressor oil that has come in contact with the atmosphere.
- (2) When troubleshooting the self-contained units (A/C-1 and 3) it will be necessary to determine operating pressures by using a portable gauge manifold. There are no fixed gauges installed in these systems. Also, use a portable gauge manifold on the accommodations unit (A/C-2) when a defective gauge is suspected on the installed fixed manifold.
- (3) Time guard circuit will delay re-starting the compressor for 5 minutes after it has been shut down for any reason.

2-14. Troubleshooting Electrical Voltages and Components. The following information is to assist maintenance personnel when troubleshooting voltages and electrical components within the HVAC system.

a. Alternating Current Voltages.

(1) Three-Wire, Single Phase, 60 Hz.

(a) FIGURE 2-1 shows power supply wires entering main electrical panel and then going to branch distribution panel or circuits.

(b) If wires are identified in a 230/1/60 supply by A, B, and G, as in FIGURE 2-1, the voltmeter readings should be:

1 A to G-115 volts.

2 A to B-230 volts.

3 B to G-115 volts.

(c) Voltage readings may be slightly higher or lower but must be within ± 10 percent of these voltages.

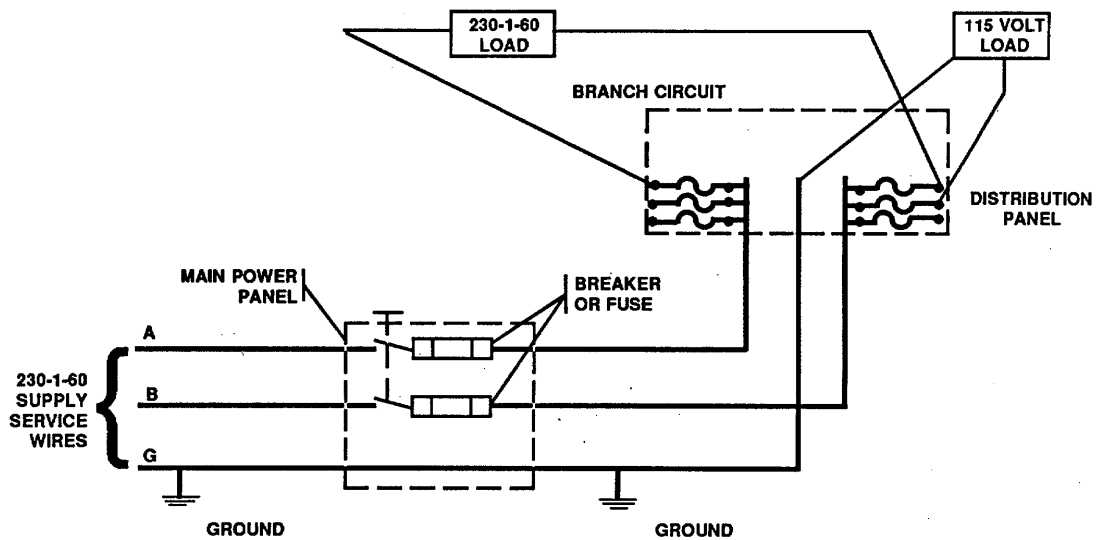

Figure 2-1. Voltage System, 115 and 230V/1 Ph/60 Hz.

(2) Three-Wire, Three Phase, 60 Hz (delta connected).

(a) FIGURE 2-2 shows power supply wires entering main electrical panel and going to branch distribution panel or circuits.

(b) If wires are identified in a 220 to 240/3-phase/60 Hz supply by A, B, and C, as in FIGURE 2-2, the voltmeter readings should be:

1 A to B-220 volts (± 10 percent); for a 220 volt requirement.

230 volts (± 10 percent); for a 230 volt requirement.

240 volts (± 10 percent); for a 240 volt requirement.

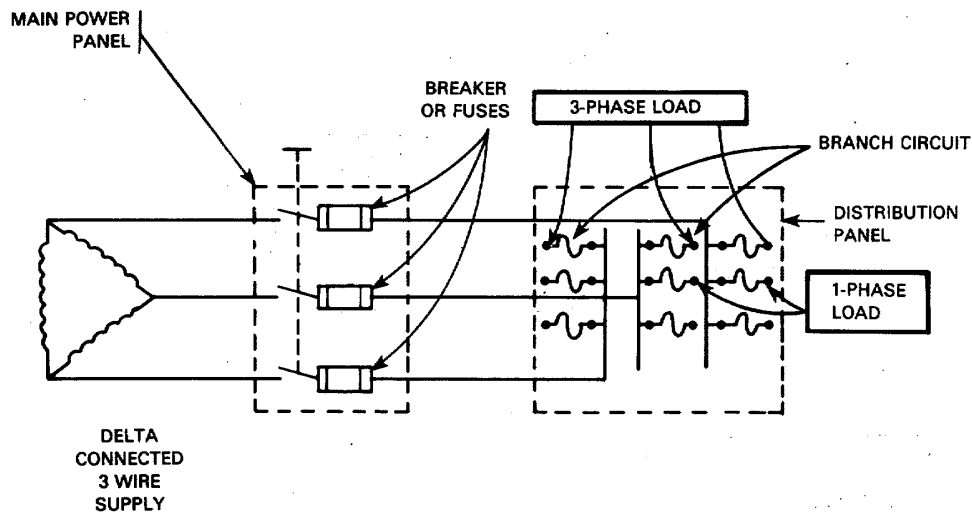

Figure 2-2. Voltage System. 220 to 240V/3 Ph/60 Hz.

2 A to C-Same as step 1.

3 B to C = Same as step 1.

(3) Always check voltmeter readings against supply voltage ratings on HVAC equipment electrical nameplates. If a low voltage exists at an HVAC unit, check the voltage again at the electrical supply entrance to the distribution panel to be sure a "voltage drop" does not exist in the branch or feeder circuit leading to the unit.

(4) Applying or operating a unit or specific component continuously at either voltage extreme (+10% or -10%) is poor practice and a shorter component life is to be expected.

b. Overload Devices.

(1) Fuses.

WARNING

Turn electrical power OFF at primary breaker to fuse block.

(a) Check for defective fuses as follows:

1 Secure all power to the fuse block.

2 Remove fuses from the circuit.

3 Check the "continuity" of each fuse with an ohmmeter. Apply an ohmmeter lead to each end of the fuse.

4 An "OPEN," or infinite, reading indicates a defective fuse that must be replaced.

5 A "CLOSED," or ZERO, reading usually indicates that the fuse is good. Install the fuses back in the circuit.

(b) If a fuse has indicated a "CLOSED" condition, but is still suspected as being defective, do the following:

WARNING

Turn electrical power OFF to avoid personal injury.

1 Secure all power to the fuseblock.

2 Remove the wires from the load side of the fuses.

- 3 In a single phase circuit, turn the power ON and check between A, and G (ground) with a voltmeter (FIGURE 2-3). If no voltage is read, the A to A₁ fuse is defective. Make the same check between B₁, and G. If no voltage is read, the B to B₁ fuse is defective.

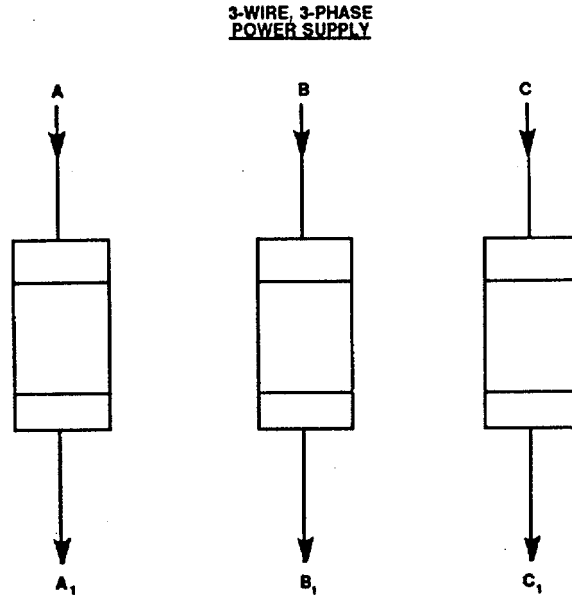

Figure 2-3. Checking Single Phase Circuit Fuses.

- 4 In a three phase circuit turn the power ON and check between A-C₁, C-B₁, and C-A₁ with a voltmeter (FIGURE 2-4). If no voltage:

A-C₁ = blown C fuse.
 C-B₁ = blown B fuse.
 C-A₁ = blown A fuse.

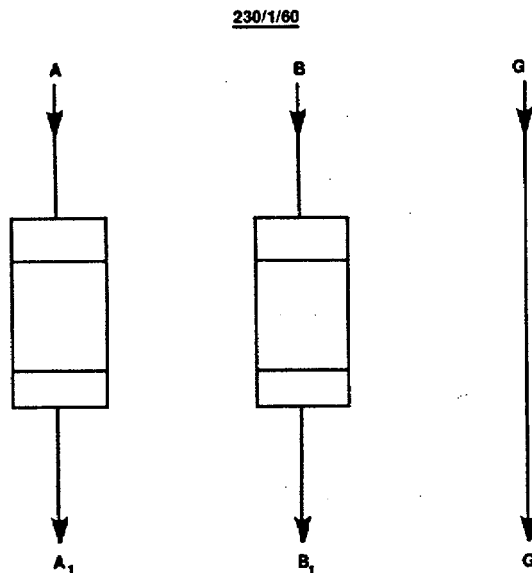

Figure 2-4. Checking Three Phase Circuit Fuses.

- 5 Replace defective fuses as required.
- (2) Circuit Breakers.
- (a) Check circuit breaker as follows:
 - 1 Push manual switch(s) to OFF then ON to be sure breaker is closed. Start all equipment being fed by breaker. Refer to, FIGURE 2-5.
 - 2 Single Phase-Measure incoming voltage across A-B and leaving voltage across A1-B1. They should be the same.
 - 3 Three Phase-Measure incoming voltage across A-B, A-C and B-C. Measure leaving voltage across A1-B1, A1-C1 and B1-C1. Incoming and leaving voltages should be the same.

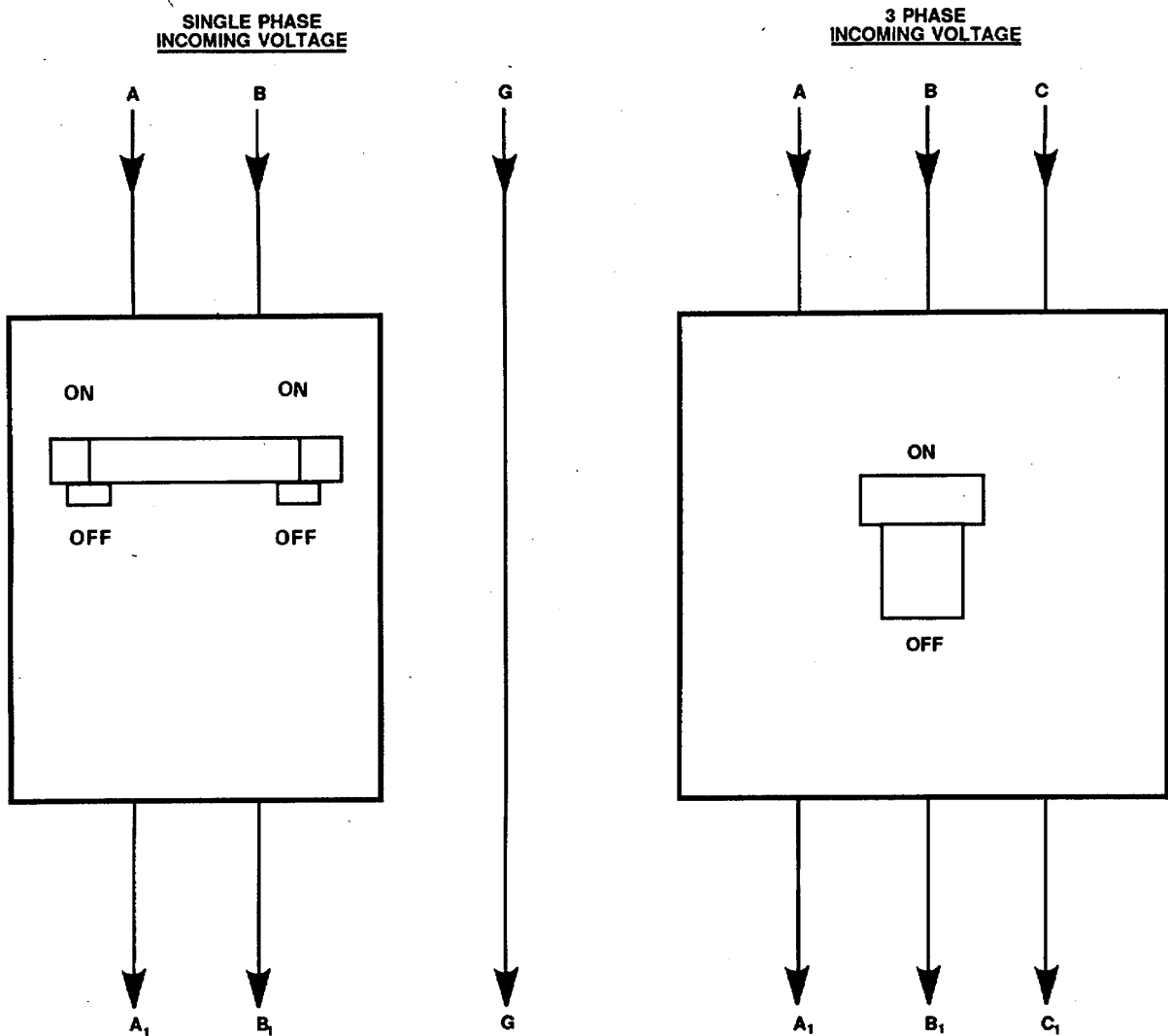

Figure 2-5. Checking Circuit Breakers.

- (b) If breaker has been tripping, reset it and check current through A-A₁, B-B₁ and C-C₁ with clamp-on ammeter. Check amp rating of breaker. It is usually stamped on breaker lever or body. Compare amp reading with breaker rating. If current through breaker is higher than rating, either a temporary overload exists or the breaker is improperly sized.
 - (c) If breaker is tripping at a current below its rating or not tripping at a higher current, replace it.
- (3) Contactors.
- (a) Check the contactor relay coil as follows:
 - 1 Turn OFF all power to unit. Remove wires from coil. Spread them apart to prevent accidental shorting or grounding.
 - 2 Use an ohmmeter to check across coil terminals. If the meter indicates a circuit, the coil is OK. If a very high resistance is indicated, the coil is open. Replace coil or complete component. If a low resistance is indicated, place one meter probe to ground or to unit frame. Touch other probe to each coil terminal. If a circuit is indicated from either terminal to ground, replace the contactor.
 - 3 Check coil voltage. It is usually indicated on the coil body, component nameplate or body. Turn ON unit power. Establish voltage both coil wires. Use a voltmeter to check voltage between coil wires. It should be the same as indicated coil voltage. If not, either coil supply voltage is incorrect (determine by further checks) or the incorrect coil is being used.
 - (b) Check the electrical contacts in the contactor:
 - 1 Before checking, determine if contacts should be normally open or normally closed when coil is deenergized.
 - 2 Turn OFF all power to unit. Remove wire leading to the load-controlled device. Use an ohmmeter to check across each set of contacts. Normally open (NO) contacts should read open or an infinite resistance. Normally closed (NC) contacts should read zero resistance. If an incorrect meter reading is obtained, remove all wires leading to component and observe if reading still indicates improper contact position. If so, inspect the contacts. Look for welded or burned contacts, metal spatter, and carbonizing. Replace the contactor if these conditions exist.

c. Capacitors.

(1) Visual check of capacitor:

WARNING

Turn power OFF and discharge capacitor to avoid electrical shock.

(a) Turn OFF unit power. Use a screwdriver with insulated handle to short capacitor terminals and discharge them to eliminate the possibility of accidental shock. Remove capacitor wires. Remove capacitor from unit and visually inspect. A bulged or leaking capacitor should be considered defective and replaced. Start capacitors usually have a relief plug or disc in their top. If the plug or disc is missing, it indicates excessive heating.

(b) Replace bulged, leaking, or overheated capacitor.

(2) Checking for shorted or open capacitor:

1 Use an ohmmeter on the 0-10,000 ohm scale setting. Place meter probes on capacitor terminals.

2 If meter needle dips to zero or a low resistance and then climbs toward a high resistance, the capacitor is probably OK. If needle dips to zero or a low resistance and stays there, the capacitor is shorted and must be replaced. If needle does not move, the capacitor is open and must be replaced.

d. Transformers.

(1) Check transformer as follows:

(a) Use a voltmeter and with the primary supply circuit ON, check the primary or input voltage.

(b) Next, check secondary or output voltage. If no voltage is available, the transformer is defective.

(2) Replace defective transformer.

e. Alternating Current Motors and Compressors

(1) The following procedure will check the condition of a three-phase motor or compressor.

(a) Use a megohmmeter (megger) for this check.

WARNING

Turn power OFF to the motor or compressor to avoid personal injury.

- (b) Turn all power OFF to the motor or compressor.
- (c) Tag and disconnect all wires from the motor or compressor terminals.
- (d) Attach one megohmmeter lead to motor or compressor frame (ground). Make sure you have a good, clean ground.
- (e) Attach the other megohmmeter lead to one of the motor or compressor terminals.
- (f) Use the following procedure to check each phase of lead to ground:
 - 1 Turn the megger handle for at least 60 seconds. Note the meter resistance values at the 10-second interval and at the 60-second interval. These readings must be higher than 5.0 megohms.
 - 2 Divide the 60-second reading by the 10-second reading. The result must be 1.15 megohms or higher.
 - 3 If the result is lower than 1.15, or if megger readings were lower than 5.0 megohms, the motor or compressor is defective and must be replaced.
- (g) Check each motor or compressor terminal by repeating steps (d) through (f) of this procedure.
- (h) Check phase-to-phase conditions as follows:
 - 1 Attach the megger leads to two of the motor or compressor terminals.
 - 2 Conduct procedure given in step (f) of this procedure.
 - 3 Repeat this procedure to check between each set of terminals on the motor or compressor.

2-15. Wiring Diagrams. Wiring diagrams are the maps of electrical circuits. You must understand them in order to determine where your components are located electrically.

- a. Before you make a connection or attempt to locate the source of an electrical problem, you must also know the following:
 - (1) What the circuit is suppose to do, and how.
 - (2) What function is performed by each component in the circuit.
 - (3) What the physical location of each component is.
 - (4) The interrelationship of the components.

- b. These things can be determined from the appropriate wiring diagram on the HVAC equipment. Wiring diagrams are located in electrical terminal boxes, on panel doors, or on motor nameplates of individual equipment.
- c. Refer to FIGURE 2-6 for the common electrical symbols used on HVAC wiring diagrams.











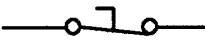
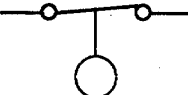
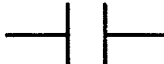
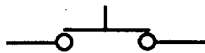
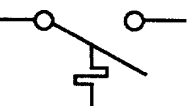

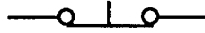

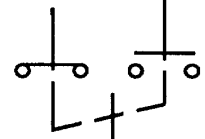
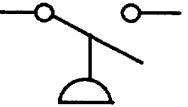

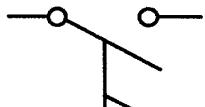
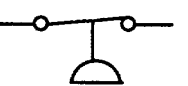

<p>SWITCH, ELECTRICALLY OPERATED *INDICATES MAGNETIC COIL, MOTOR, OR THERMAL ELEMENT</p> 	<p>FOOT NORMALLY CLOSED</p> 	<p>LIQUID LEVEL OPEN WITH LEVEL RISE</p> 
<p>NO CONTACTS</p> 	<p>PUSHBUTTON MOMENTARY CONTACT NORMALLY CLOSED</p> 	<p>TEMPERATURE CLOSE ON TEMP RISE</p> 
<p>NC CONTACTS</p> 	<p>PUSHBUTTON MOMENTARY CONTACT NORMALLY OPEN</p> 	<p>TEMPERATURE OPEN ON TEMP RISE</p> 
<p>TIME DELAY RELAY CONTACTS ENERGIZED NO</p> 	<p>PUSHBUTTON MAINTAINED CONTACT</p> 	<p>PRESSURE CLOSE WITH PRESSURE RISE</p> 
<p>ENERGIZED NC</p> 	<p>TOGGLE SWITCH, MECHANICALLY OPERATED FLOW CLOSE WITH FLOW</p> 	<p>PRESSURE OPEN WITH PRESSURE RISE</p> 
<p>DE-ENERGIZED NO</p> 	<p>FLOW OPEN WITH FLOW</p> 	<p>TRANSFORMER AUTO TRANSFORMER</p> 
<p>DE-ENERGIZED NC</p> 	<p>LIMIT NORMALLY OPEN</p> 	<p>CURRENT TRANSFORMER</p> 
<p>SWITCH, MANUALLY OPERATED DISCONNECT (3 POLE SWITCH SHOWN)</p> 	<p>LIMIT NORMALLY CLOSED</p> 	<p>POTENTIAL TRANSFORMER</p> 
<p>FOOT NORMALLY OPEN</p> 	<p>LIQUID LEVEL CLOSE WITH LEVEL RISE</p> 	<p>VARIABLE TRANSFORMER</p> 

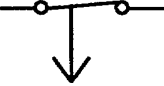
Figure 2-6. *Electrical Symbols (Sheet 1 of 2).*

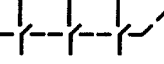
<p>BATTERY</p>	<p>FUSE</p>	<p>MOTOR 1-PHASE 1-PHASE INDUCTION</p>
<p>CABLE, SHIELDED (GROUNDED)</p>	<p>FUSE LINK</p>	<p>RESISTOR FIXED</p>
<p>CAPACITOR FIXED</p>	<p>GLOW COIL</p>	<p>TAPPED</p>
<p>POLARIZED</p>	<p>GROUND CONNECTION</p>	<p>VARIABLE</p>
<p>VARIABLE</p>	<p>HEATER CRANKCASE HEATER STRIP HEATER</p>	<p>SOLENOID</p>
<p>CIRCUIT BREAKER THERMAL TRIP</p>	<p>INDUCTOR FIXED</p>	<p>SWITCH, GENERAL SINGLE-POLE SINGLE-THROW</p>
<p>MAGNETIC TRIP</p>	<p>VARIABLE</p>	<p>SINGLE-POLE DOUBLE-THROW</p>
<p>CROSSOVER</p>	<p>LIGHT *INDICATES COLOR</p>	<p>MULTI-POLE, SINGLE-THROW</p>
<p>ELECTRODE, IGNITER</p>	<p>METER *INDICATES TYPE</p>	<p>MULTI-POLE DOUBLE-THROW</p>

Figure 2-6. *Electrical Symbols (Sheet 2 of 2).*

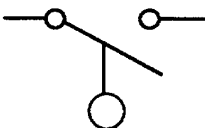
SECTION V. UNIT MAINTENANCE PROCEDURES

2-16. General. This section covers unit maintenance procedures for the environmental control subsystem. Step by step procedures, illustrated where necessary, are provided for replacement of components. No separate procedures are included for equipment for which repair parts are not stocked. Additional information is available in the operator's manual, TM 55-1905-223-10, for HVAC operation and equipment location.

MAINTENANCE OF ENVIRONMENTAL CONTROL SUBSYSTEM

2-17. Repair Heater, Duct Type, Stationary (Duct #1). (FIGURE 2-7)

This task covers: a. **Repair.**

INITIAL SETUPTools

Tool kit, general mechanic's,
5180-00-699-5273
Tool kit, electrician's,
5180-00-391-1087

Equipment Condition

Circuit breaker switched OFF, power
panel locked and tagged "Out of
Service-Do Not Operate."

Materials/Parts

Cartridge fuse P/N OT-20
Heating element P/N 33904
Electrical tag, Item 1, Appendix C

REPAIR

Repair consists of replacing cartridge fuses (3) and heating elements (7).

- a. Replace cartridge fuse.

WARNING

Secure heater access doors in their full open position to avoid personal head injury.

- (1) Open heater access doors (2).
- (2) Check for defective cartridge fuse (3). Refer to paragraph 2-15.

NOTE

Ensure cartridge fuse is properly marked and identified for assembly.

- (3) Remove defective cartridge fuse (3) from transformer block (4).

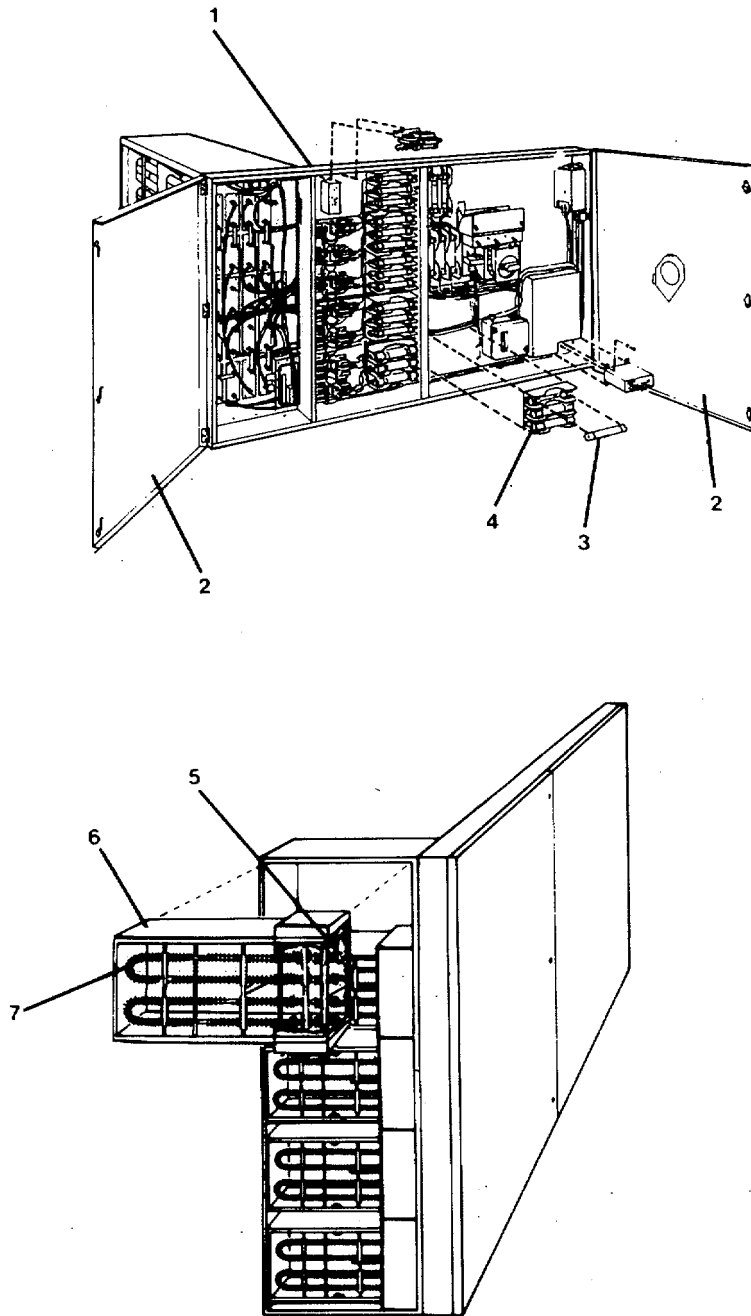

Figure 2-7. Duct Heater (Duct #1).

- (4) Install replacement cartridge fuse (3).

b. Replace Heating Element.

- (1) Tag electrical line connections (5) at terminal ends of heating element (7).
- (2) Remove terminal screws and washers.
- (3) Separate line connections from terminal ends of heating element.
- (4) Remove mounting flange screws securing heating assembly (6) to terminal box (1).
- (5) Slide heating assembly out of terminal box enclosure.
- (6) Slide heating assembly (6) into terminal box enclosure (1).
- (7) Secure heating assembly (6) to terminal box with mounting flange screws.
- (8) Install electrical line connections on terminal ends (5) of heating element (7) as tagged.

CAUTION

When making line connections to heating element terminals FOR FINNED TUBULAR HEATERS ONLY, apply a 1/4-inch wrench to flat section of terminal immediately below threads. Otherwise, damage to terminal may result.

- (9) Secure line connections (5) to heating element with terminal washers and screws.

c. Operational Check.

- (1) Unlock power panel, switch circuit breaker ON.
- (2) Refer to TM 55-1905-223-10 for details on control settings.
- (3) Close and secure heater access doors.
- (4) Remove "Out of Service - Do Not Operate" tag from circuit breaker.

2-18. Repair Heater, Duct Type, Stationary (Duct #2). (FIGURE 2-8)

This task covers:

a. Repair

INITIAL SETUP:

Tools

Tool kit, general mechanic's,
5180-00-699-5273
Tool kit, electrician's,
5180-00-391-1087

Equipment Condition

Circuit breaker switch OFF, power panel
locked and tagged "Out of Service -
Do Not Operate."

Materials/Parts

Heating element P/N 52424175
Electrical tag, Item 1, Appendix C

REPAIR

Repair consists of replacing heating element.

- a. Open heater front cover (7).
- b. Tag electrical line connections at terminal ends of heating element (4).
- c. Remove terminal nuts (6) and washers (5) securing heating element (4) to mounting flange (3).
- d. Separate line connections from terminal ends of heating element (4).
- e. Remove four mounting flange screws (2) securing heating assembly to terminal box (1) at top and bottom.
- f. Slide heating assembly out of terminal box enclosure (1).
- g. Remove heater elements (4).
- h. Slide heating assembly into terminal box enclosure (1)
- i. Install heating element (4) in mounting flange (3).
- j. Secure heating assembly to terminal box enclosure (1) with four mounting flange screws (2) at top and bottom.

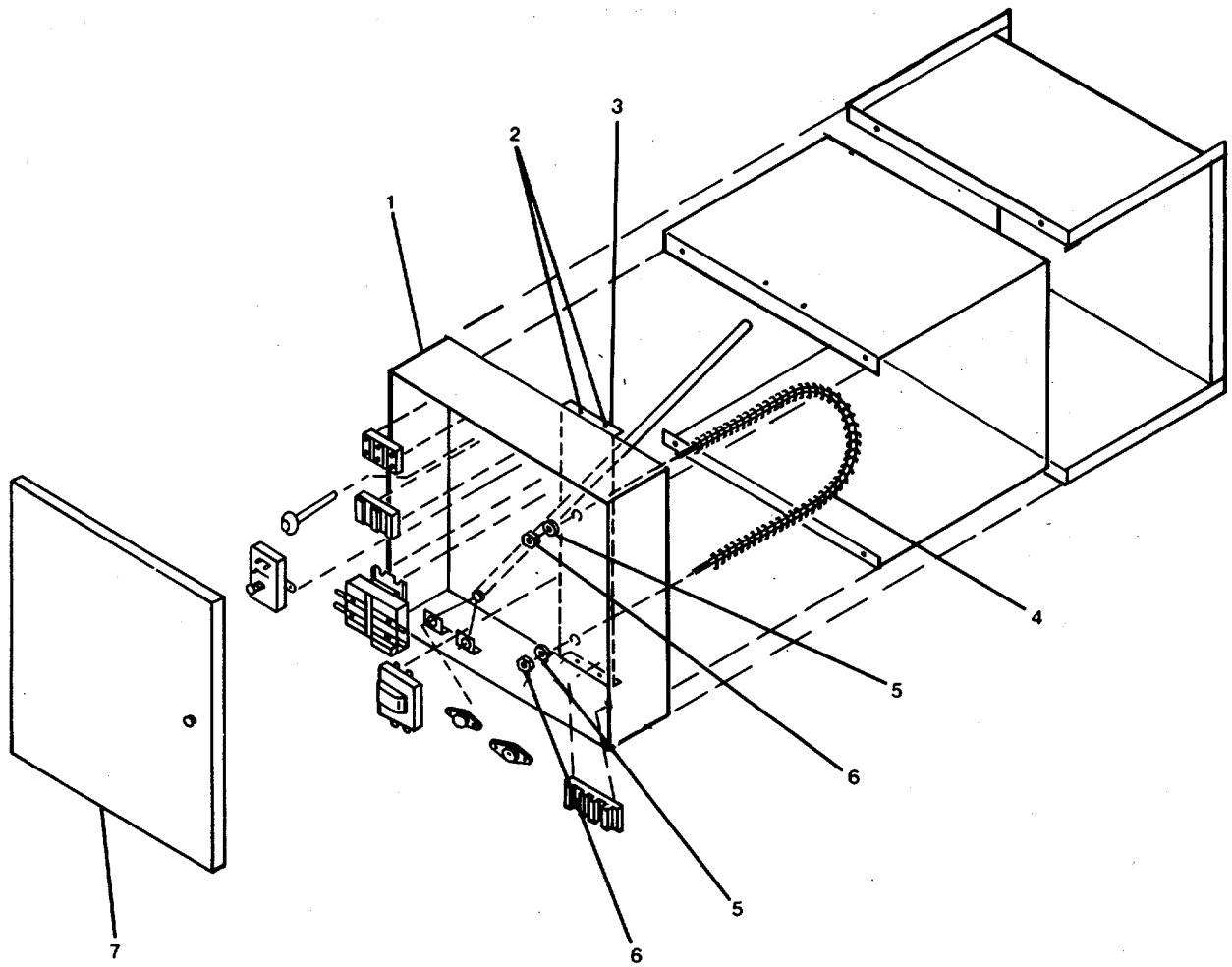

Figure 2-8. Duct Heater (Duct #2).
2-49

- k. Install electrical line connection on terminal ends of heating element (4) as tagged.

CAUTION

When making line connections to heating element terminals FOR FINNED TUBULAR HEATERS ONLY, apply a 1/4-inch wrench to flat section of terminal immediately below threads. Otherwise, damage to terminal may result.

- l. Secure heating element (4) with terminal washers (5) and nuts (6) to mounting flange (3).
 - m. Close heater front cover (7).
 - n. Operational check.
- (1) Unlock power panel and switch circuit breaker ON.
 - (2) Refer to TM 55-1905-223-10 for details on control settings.
 - (3) Remove "Out of Service - Do Not Operate" tag from circuit breaker.

2-19. Repair Heater, Duct Type, Stationary (Duct #3). (FIGURE 2-9)

This task covers:

a. Repair

INITIAL SETUP :Tools

Tool kit, general mechanic's,
5180-00-699-5273
Tool kit, electrician's,
5180-00-391-1087

Equipment Condition

Circuit breaker switch OFF, power panel
locked and tagged "Out of Service
Do Not Operate."

Materials/Parts

Cartridge fuse P/N 40526001
Heating element P/N 52424176
Electrical tag, Item 1, Appendix C

REPAIR

Repair consists of replacing cartridge fuses and heating elements.

- a. Replace cartridge fuse.
 - (1) Open heater front cover (7).
 - (2) Check for defective cartridge fuse (8), paragraph 2-17.

NOTE

Ensure cartridge fuse is properly marked and identified for assembly.

- (3) Remove defective cartridge fuse (8) from block fuseholder (9).
- (4) Install replacement cartridge fuse (8) in block fuseholder (9).
- b. Replace heating element.
 - (1) Tag electrical line connections at terminal ends of heating element (4).
 - (2) Remove terminal nuts (6) and washers (5) securing heating element (4) to mounting flange (3).

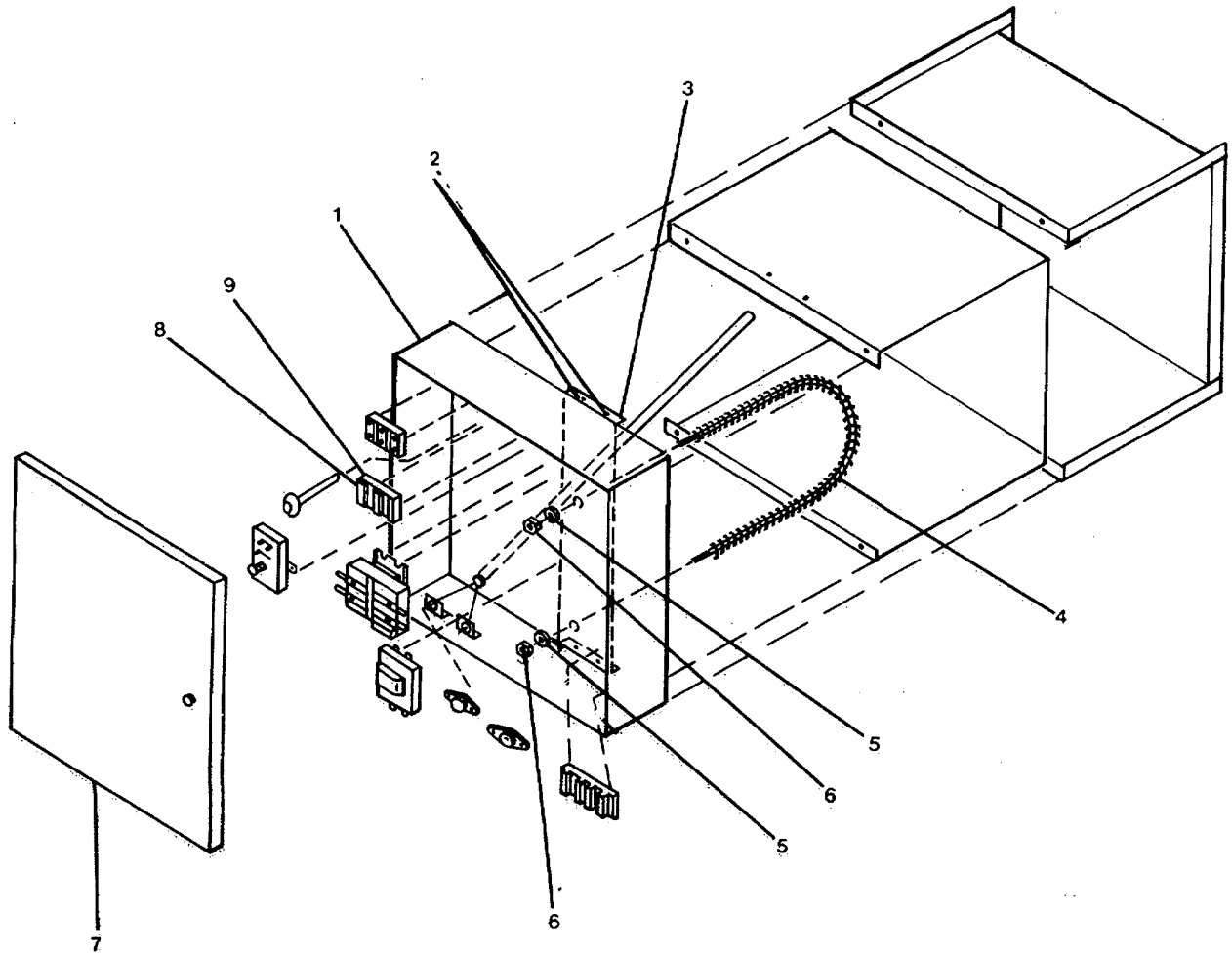

Figure 2-9. Duct Heater (Duct #3).

- (3) Separate line connections from terminal ends of heating element (4).
- (4) Remove four mounting flange screws (2) securing heating assembly to terminal box (1).
- (5) Slide heating assembly out of terminal box enclosure (1).
- (6) Install heating element (4) into mounting flange (3).
- (7) Slide heating assembly into terminal box enclosure (1).
- (8) Secure heating assembly to terminal box (1) with four mounting flange screws (2) at top and bottom.
- (9) Install electrical line connections on terminal ends of heating element (4) as tagged.

CAUTION

When making line connections to heating element terminals
FOR FINNED TUBULAR HEATERS ONLY, apply a 1/4-inch
wrench to flat section of terminal immediately below threads.
Otherwise, damage to terminal may result.

- (10) Secure heating element (4) with terminal washers (5) and screws (6).
- (11) Close heater front cover (7).
- (12) Operational check:
 - (a) Unlock power panel and switch circuit breaker ON.
 - (b) Refer to TM 55-1905-223-10 for details on control settings.
 - (c) Remove "Out of Service - Do Not Operate" tag from circuit breaker.

2-20. Repair Heater, Duct Type, Stationary (Ducts #4 through #7), (Ducts #9 through #12) and (Ducts #12A, #14, #16, and #17). (FIGURE 2-10)

This task covers:

a. **Repair**

INITIAL SETUP:

Tools

Tool kit, general mechanic's,
5180-00-699-5273
Tool kit, electrician's,
5180-00-391-1087

Equipment Condition

Circuit breaker switch OFF, power panel
locked and tagged "Out of Service -
Do Not Operate."

Materials/Parts

Heating element P/N 52424179
(Ducts 4, 6, 9, 12, 12A, and 14)
P/N 52424178 (Ducts 5, 7, 10, 11, and
16) P/N 52424180 (Duct 17)
Electrical tag, Item 1, Appendix C

REPAIR

Repair consists of replacing heating elements.

- a. Open heater front cover (7).
- b. Tag electrical line connections at terminal ends of heating element (4).
- c. Remove terminal nuts (6) and washers (5).
- d. Separate line connections from terminal ends of heating element (4).
- e. Remove mounting flange screws (2) securing-heating assembly (3) to box (1) at top and bottom.
- f. Slide heating assembly (3) out of terminal box enclosure (1).
- g. Remove heating element (4).
- h. Install heating element (4) into heater assembly (3).
- i. Slide heating element (3) into terminal box enclosure (1).

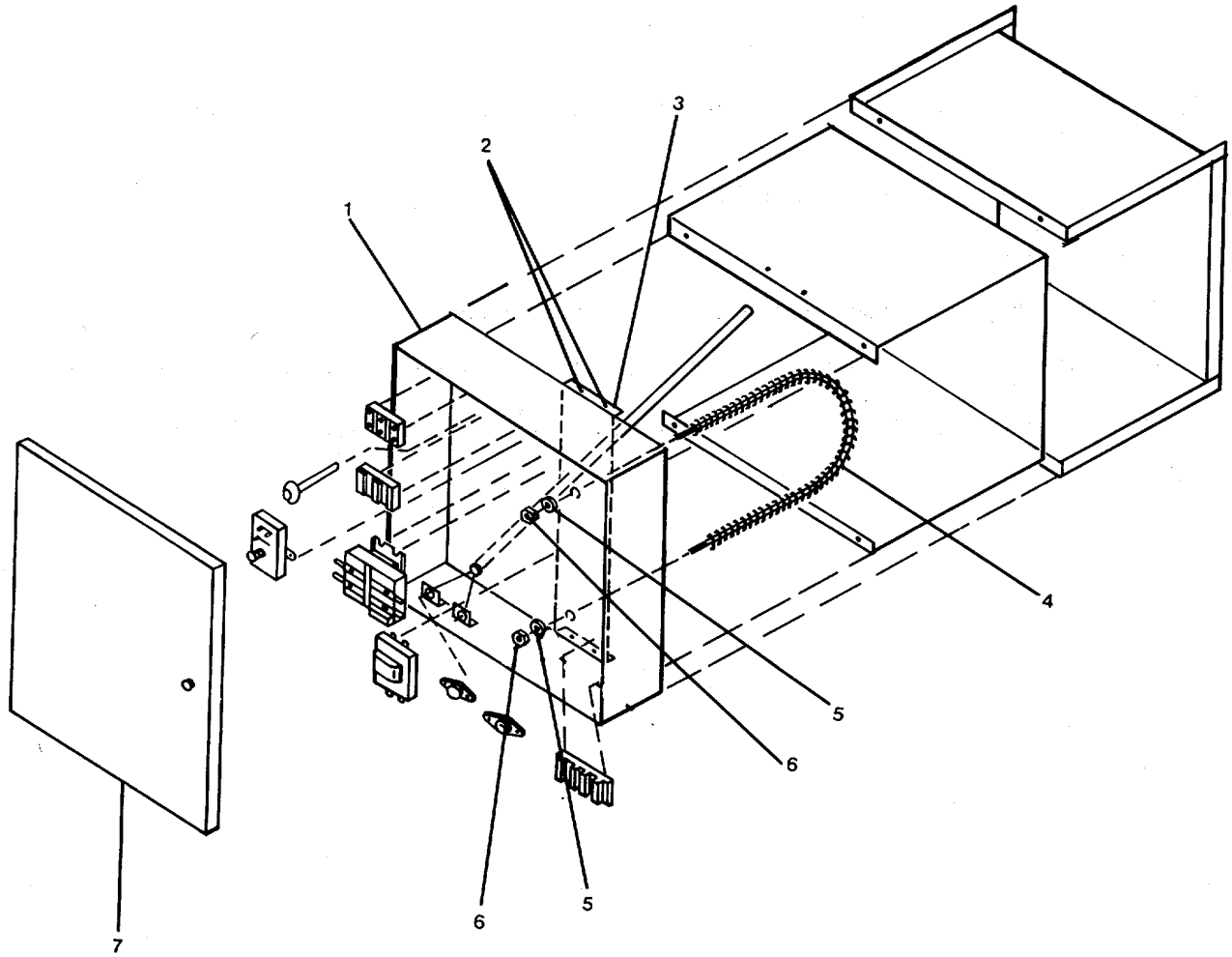

Figure 2-10. Ducts Heater (Ducts #4 through #7; #9 through #12; #12A, #14, #16, and #17).

- j. Secure heating assembly (3) to terminal box (1) with mounting flange screws (2) at top and bottom.
- k. Install electrical line connections on terminal ends of heating element (4) as tagged.

CAUTION

When making line connections to heating element terminals FOR FINNED TUBULAR HEATERS ONLY, apply a 1/4-inch wrench to flat section of terminal immediately below threads. Otherwise, damage to terminal may result from element twisting.

- l. Secure line connections to heating element (4) with terminal washers (5) and nuts (6).
- m. Close heater front cover (7).
- n. Operational check:
 - (1) Unlock power panel and switch circuit breaker ON.
 - (2) Refer to TM 55-1905-223-10 for details on control settings.
 - (3) Remove "Out of Service - Do Not Operate" tag from circuit breaker.

2-21. Repair Heater, Duct Type, Stationary (Ducts #8, #13, and #15). (FIGURE 2-11)

This task covers:

a. Repair

INITIAL SETUP:

Tools

Tool kit, general mechanic's,
5180-00-699-5273
Tool kit, electrician's,
5180-00-391-1087

Equipment Condition

Circuit breaker switch OFF, power panel
locked and tagged "Out of Service -
Do Not Operate."

See TM 55-1905-223-10 for HVAC systems
operation and equipment location.

Materials/Parts

Heating element
P/N 52424177 (Duct 8)
P/N 52424178 (Ducts 8, 13, and 15)
P/N 52424179 (Ducts 13 and 15)
Electrical tag, Item 1, Appendix C

REPAIR

Repair consists of replacing heating elements.

- a. Open heater front cover (7).
- b. Tag electrical line connections at terminal ends of heating element (4).
- c. Remove terminal nuts (6) and washers (5).
- d. Separate line connections from terminal ends of heating element (4).
- e. Remove mounting flange screws (2) securing heating assembly (3) to terminal box (1).
- f. Slide heating assembly (3) out of terminal box enclosure (1).
- g. Remove heating elements (4).
- h. Install heating elements (4) into heating assembly (3).
- i. Slide heating assembly (3) into terminal box enclosure (1).

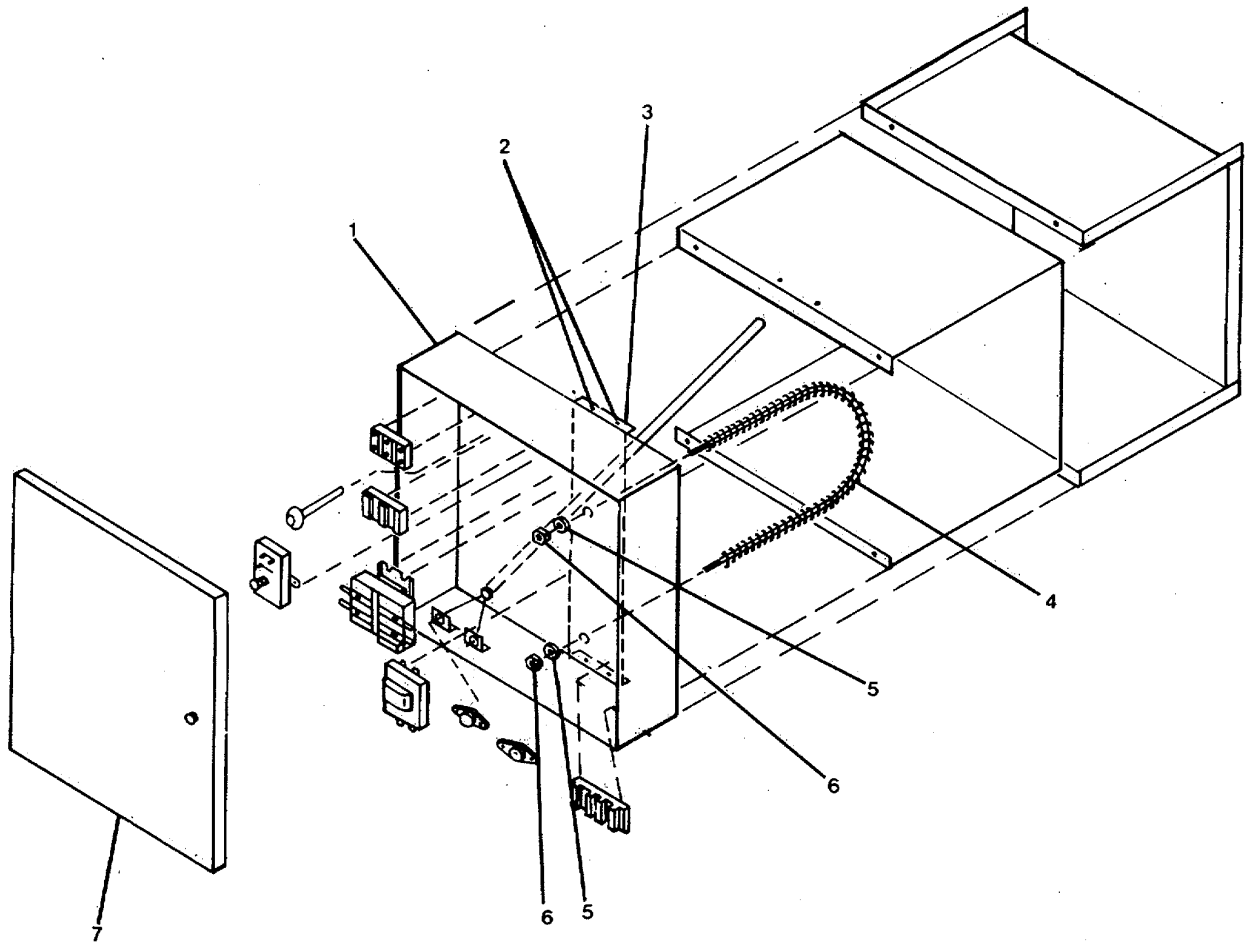

Figure 2-11. Duct Heater (Ducts #8, #13, and #15).

- j. Secure heating assembly (3) to terminal box (1) with mounting flange screws (2).
- k. Install electrical line connections on terminal ends of heating element (4) as tagged.

CAUTION

When making line connections to heating element terminals FOR FINNED TUBULAR HEATERS ONLY, apply a 1/4-inch wrench to flat section of terminal immediately below threads. Otherwise, damage to terminal may result.

- l. Secure line connections to heating element (4) with terminal washers (5) and nuts (6).
- m. Close heater front cover (7).
- n. Operational check:
 - (1) Unlock power panel and switch circuit breaker ON.
 - (2) Refer to TM 55-1905-223-10 for details on control settings.
 - (3) Remove "Out of Service - Do Not Operate" tag from circuit breaker.

2-22. Repair Heater, Space, Electric (Units #1, #2, #4, #9, #10, and #11). (FIGURE 2-12)

This task covers:

a. Repair

INITIAL SETUP:

Tools

Tool kit, general mechanic's,
5180-00-699-5273
Tool kit, electrician's,
5180-00-391-1087

Equipment Condition

Circuit breaker switch OFF, power
panel locked and tagged "Out of
Service - Do Not Operate."

See TM 55-1905-223-10 for HVAC systems
operation and equipment location.

Materials/Parts

Heating element (Units 4 and 10)
P/N 118-130370-016
Heating element (Units 9 and 11)
P/N 118-130374-021
Heating element (Units 1 and 2)
P/N 118-130370-022
Electrical tag, Item 1, Appendix C

REPAIR

Repair consists of replacing heating elements.

- a. Remove mounting screws (1) securing front case (2) to heater case (3).
- b. Tag and disconnect electrical wires from heating element (4).
- c. Remove attaching hardware (5) from shield (6) and remove heating element (4).
- d. Install heating element as follows:
 - (1) Connect electrical wires to heating element (4) as tagged.
 - (2) Install attaching hardware (5) to heating element assembly (4).
 - (3) Attach heating element (4) to shield (6).
- e. Install front case (2) to heater case (3) with mounting screw (1).

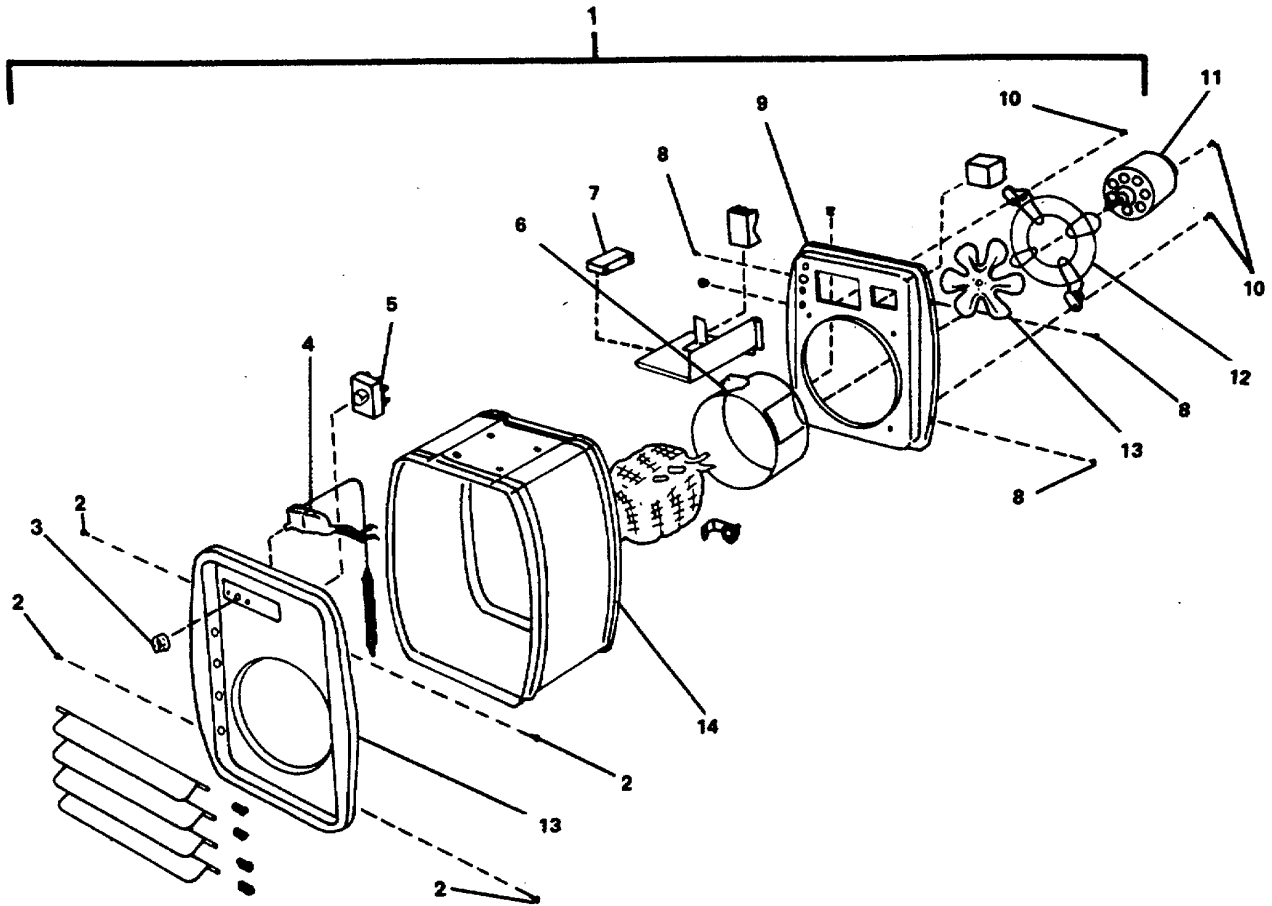

Figure 2-12. Electrical Space Heater (Units #1. #2. #4. #9. #10. and #11).

2-23. Repair Heater, Space, Electric (Units #3, #5, #6, and #7). (FIGURE 2-13)**This task covers:****a. Repair****INITIAL SETUP:**Tools

Tool kit, general mechanic's, 5180-00-699-5273
 Tool kit, electrician's, 5180-00-391-1087

Equipment Condition

Circuit breaker switch OFF, power panel locked and tagged "Out of Service - Do Not Operate."

See TM 55-1905-223-10 for HVAC systems operation and equipment location.

Materials/Parts

Heating element (Units 3 and 5)
 P/N 571U-69799-04303
 Heating element (Unit 6)
 P/N 571U-72519-04303
 Heating element (Unit 7)
 P/N 571U-71099-0430
 Element gaskets P/N F121-011
 Electrical tags, Item 1, Appendix C

REPAIR

Repair consists of replacing the heating elements and gaskets.

- a. Remove mounting screws (1) securing metal grille (3) to heater enclosure (2). Remove metal grille (2).
- b. Unscrew and remove bottom cover (5) of heater to gain access to element wiring.
- c. Tag and disconnect electrical wires from terminal ends of heating element (4) by removing washers and screws.
- d. Remove attaching hardware and remove heating element (4) and gasket (6).
- e. Install attaching hardware and install heating element (4) and gasket (6).
- f. Install electrical wires to terminal ends of heating element (4) with washers and screws.
- g. Thread bottom cover (5) securely onto heater housing.

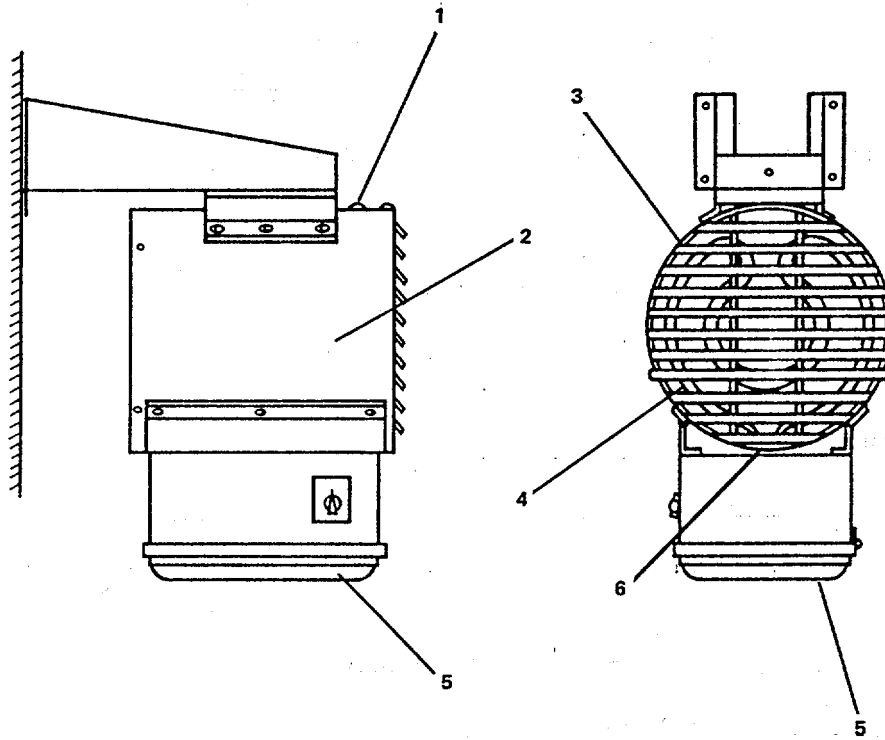

Figure 2-13. Electric Space Heater (Units #3, #5, #6, and #7).

- h. Install metal grille (3) on heater enclosure (2) with mounting screws (1).
- i. Operational check:
 - (1) Unlock power panel and switch circuit breaker ON.
 - (2) Refer to TM 55-1905-223-10 for details on control settings.
 - (3) Remove "Out of Service - Do Not Operate" tag from circuit breaker.

2-24. Repair Fan, Ventilating (Supply Fan #3). (FIGURE 2-14)

This task covers:

a. Repair

INITIAL SETUP:

Tools

Tool kit, general mechanic's,
5180-00-699-5273
Tool kit, electrician's,
5180-00-391-1087
Puller, 5120-00-516-3i20
Hydraulic Press, PN 2009-13

Equipment Condition

Alternating current motor removed
(paragraph 3-18).

Materials/Parts

Bearings PN 416821-2D

REPAIR

Repair consists of replacing the motor bearings.

- a. Disassemble motor (1) as follows:
 - (1) Remove woodruff key (15) from shaft spline.
 - (2) Remove bolt (17) and remove back end bracket (11) and dirt deflector (14).
 - (3) Remove fan cover bolt (7) and remove fan cover (2). Remove grease entry tube (4) from bracket (5).
 - (4) Remove fan clamp (24) and remove outer fan (3) from motor shaft (16).
 - (5) Remove front end bracket bolt (6) and remove front end bracket (5). Remove washer (23).
 - (6) Remove the shaft (16) and bearings (12, 22) assembly from the motor.
 - (7) Make the following measurements and records:
 - (a) Measure the distance from back bearing (12) to the impeller end of the shaft (16).
 - (b) Measure the distance from front bearing (22) to the outer fan (3) end of the shaft (16).

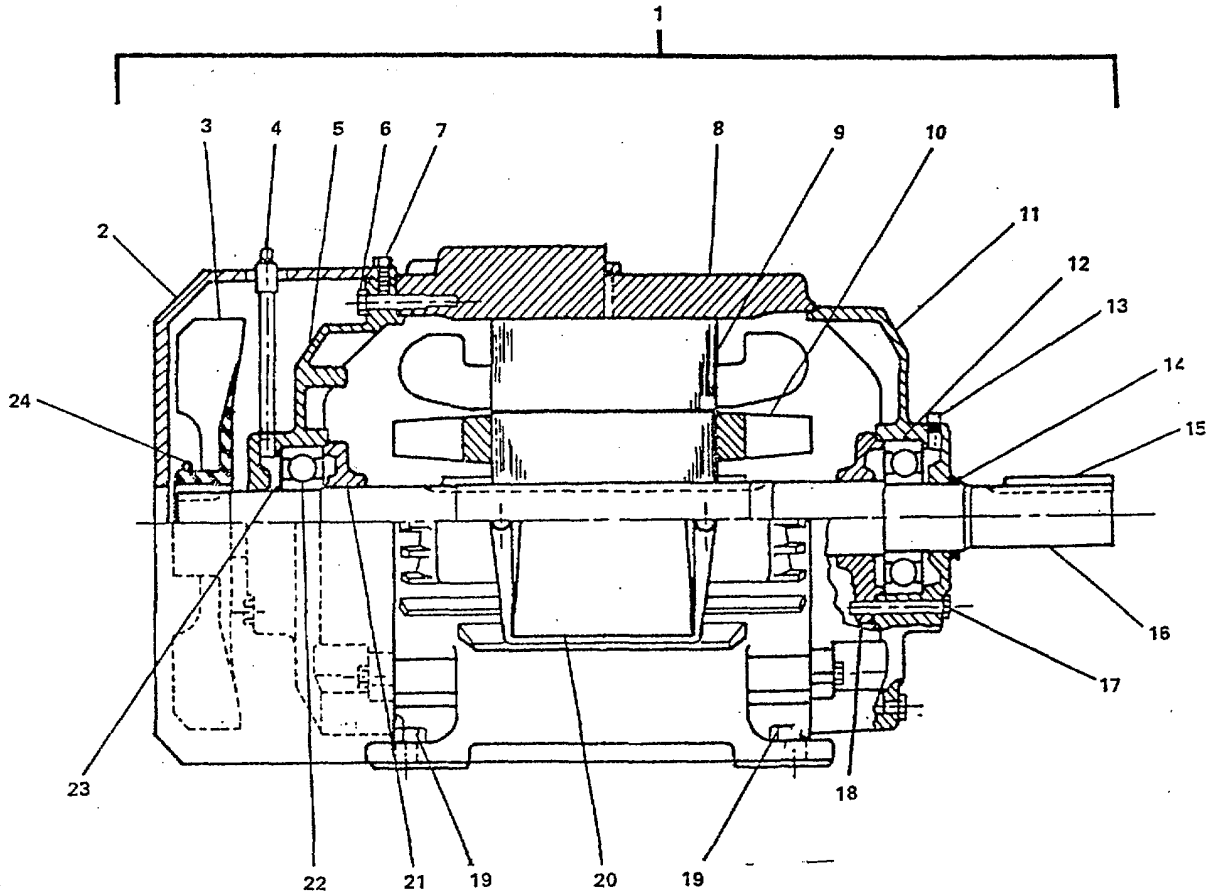

Figure 2-14. Alternating Current Motor (SF #3)

- (8) Use a puller and remove bearings (12, 22) and inner caps (18, 21) from shaft (16).
- b. Assemble motor (1) as follows:
 - (1) Use a hydraulic press and install new bearings (12, 22) on shaft (16).
 - (a) Make sure the collars are facing each other on the shaft.
 - (b) Refer to measurements recorded and place bearings on shaft in same positions as old bearings that were removed.
 - (2) Install the shaft (16) and bearings (12, 22) assembly into the motor.
 - (3) Install washer (23) and front end bracket (5). Install bracket bolt (6).
 - (4) Install outer fan (3) on motor shaft and install fan clamp (24).
 - (5) Align grease entry tube (4) and install fan cover (2). Install fan cover bolts (7).
 - (6) Install back end bracket (11) and dirt deflector (14). Install bolts (17).
 - (7) Position woodruff key (15) in shaft spline.
 - (8) Install motor (1) onto fan unit (paragraph 3-17).

2-25. Repair Fan, Ventilating (Supply Fan #4) (Bowthrustrer Room). (FIGURE 2-15)

This task covers:

- | | |
|---------------|----------------|
| a. Adjustment | b. Removal |
| c. Repair | d. Replacement |

INITIAL SETUP :Tools

Tool kit, general mechanic's,
5180-00-699-5273
Tool kit, electrician's,
5180-00-391-1087
Puller, 5120-00-516-3120

Materials/Parts

Ventilating fan P/N 716800-01
Machine key P/N 100500-01
V-belt P/N 725537-39

Equipment Condition

Circuit breaker switch OFF, power panel locked and tagged "Out of Service - Do Not Operate."

See TM 55-1905-223-10 for HVAC systems operation and equipment location.

WARNING

Make sure electrical power is OFF to avoid personal injury.

ADJUSTMENT

- a. Adjust and align fan and motor pulleys.
- (1) Remove bolts (12, two on each side) and remove weather cover (1) for access to belt and motor.
 - (2) Visually check pulley alignment before adjusting V-belt. Loosen bolts, nuts and lockwashers (8) to relieve tension on belt.
 - (a) Make sure motor pulley (3) is aligned properly with fan pulley (11).
 - (b) To align pulleys, loosen the four bolts, nuts, and washers (6) holding the motor (5) to the base plate (7) and adjust the motor as required.
 - (c) When pulleys are aligned, secure bolts, nuts, and washers (6) firmly.

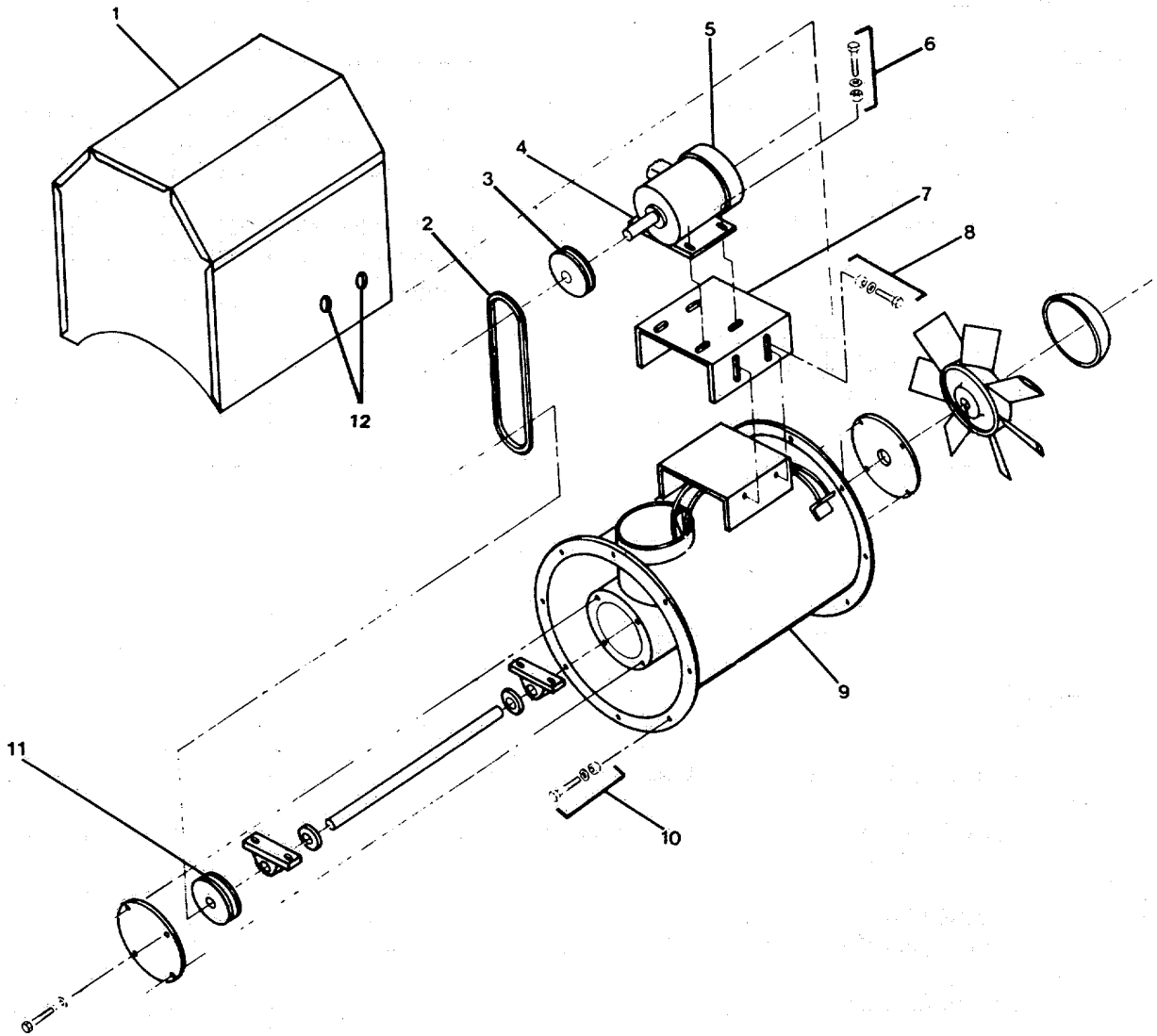

Figure 2-15. Ventilating Fan (Supply Fan #4).

b. Adjust V-belt tension.

- (1) Remove bolts (12) and remove weather cover (1) for access to belt and motor.
- (2) Loosen the four bolts, nuts, and lockwashers (8).
- (3) Pull back, or out, on motor base plate (7) to increase tension on V-belt (2).
- (4) Keep tension on motor and base while tightening bolts, nuts, and lockwashers (8).
- (5) Tighten bolts, nuts, and washers (8) firmly.
- (6) Install mounting bolts (12, two on each side) to secure weather cover (1).

REMOVAL

WARNING

Make sure electrical power is OFF to avoid personal injury.

- a. Remove bolts (12, two on each side) and weather cover (1).
- b. Tag and disconnect electrical wiring from motor (5).

WARNING

Support the fan assembly to prevent it falling when hardware is removed.

- c. Support fan assembly and remove mounting bolt, nut, and lockwasher assemblies (10) from each end of the fan drum (9).
- d. Remove the fan assembly.

REPAIR

Repair consists of replacing the V-belt (2) and machine key (4).

- a. Replace V-belt (2).
 - (1) Remove bolts (12) and weather cover (1).
 - (2) Loosen adjusting bolt, nut, and lockwasher assemblies (8) until base (7) slides down, to loosen tension on V-belt.

- (3) Remove V-belt (2) from around pulley (3) on motor shaft and pulley (11) on fan shaft.
- (4) Install new belt on pulleys (3) and (11).
- (5) Adjust belt tension. Refer to adjustment step in this procedure.

b. Replace machine key (4).

- (1) Use a puller and remove pulley (3) from motor shaft.
- (2) Remove machine key (4) from shaft spline.
- (3) Install new machine key (4) into shaft spline on motor.
- (4) Align and install pulley (3) onto motor shaft.
- (5) Install V-belt (2) and adjust tension. Refer to adjustment step in this procedure.

REPLACEMENT

- a. Position and support the fan assembly.
- b. Install mounting bolt, nut, and lockwasher assemblies (10) in each end of the fan drum (9).
- c. Adjust belt as required (refer to adjustment step in this procedure).
- d. Connect electrical wires to their proper terminals on the motor (5).
- e. Install weather cover (1) with bolts (12).
- f. Operational check:
 - (1) Turn electrical power ON.
 - (2) Start and run fan to check for proper operation.
 - (3) Remove "Out of Service" tag from circuit breaker.

2-26. Replace/Repair Motor, Electric, Alternating Current (Supply Fan #4). (FIGURE 2-16)

This task covers: a. Removal, b. Repair, c. Replacement.

INITIAL SETUPTools

Tool kit, general mechanic's,
5180-00-699-5273
Tool kit, electrician's,
5180-00-391-1087
Puller 5120-00-516-3120
Hydraulic press PN 2009-13

Equipment Condition

Circuit breaker switch OFF, power
panel locked and tagged "Out of
Service - Do Not Operate."

See TM 55-1905-223-10 for HVAC systems
operation and equipment location.

Materials/Parts

AC electric motor
P/N 355790Y606
Annular ball bearing P/N 203
Bearing P/N 205
Tag, Item 1, Appendix C
Grease, Item 2, Appendix C

WARNING

Make sure electrical power is OFF to avoid personal injury.

REMOVAL

- a. Remove weather cover from fan assembly for access to motor (paragraph 2-25).
- b. Tag and disconnect electrical wiring in motor terminal box (9, FIGURE 2-16).
- c. Refer to paragraph 2-25 and FIGURE 2-15, and remove the motor as follows:
 - (1) Loosen tension on V-belt. Remove belt from around motor pulley (3, FIGURE 2-15).
 - (2) Use a puller and remove the motor pulley (3) and machine key (4).
 - (3) Remove motor mounting bolt, nut, and lockwasher assemblies (6).
 - (4) Remove the motor (5) from the motor base (7).

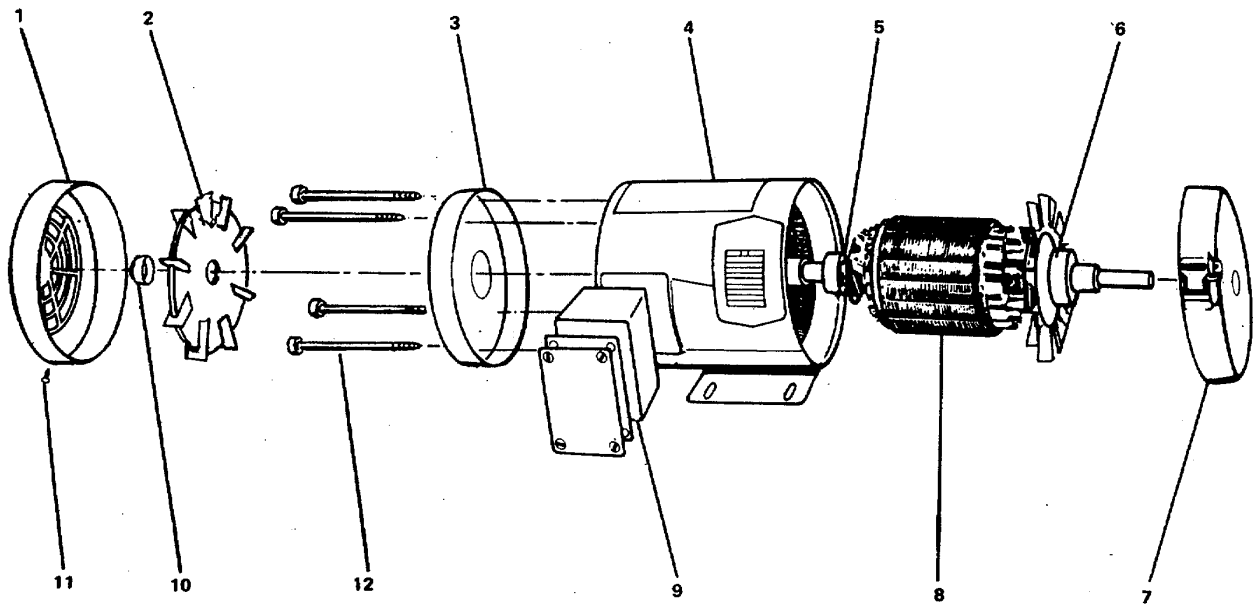

Figure 2-16. Alternating Current Electric Motor.

REPAIR

Repair consists of replacing bearings (5) and (6), FIGURE 2-16.

a. Removal of bearings:

- (1) Remove screws (11) and remove fan cover (1).
- (2) Remove locking hub (10) and external fan (2).

NOTE

Place reference marks on end plates (3) and (7) and housing for reinstallation alignment.

- (3) Remove thru bolts (12) and end plates (3) and (7).
- (4) Remove the rotor (8).
- (5) Use puller and remove annular bearing (5) from non-drive end of the rotor (8).
- (6) Use puller and remove bearing (6) from drive shaft.

b. Replacement of bearings:

- (1) Install new bearing (6) on drive shaft with a hydraulic press.

- (2) Use the press and install new annular bearing (5) onto non-drive end of the rotor (8).
- (3) Make sure rotor is properly positioned in the motor housing (4).

NOTE

Align end plates (3) and (7) using marks previously made during disassembly.

- (4) Install end plates (3) and (7).
 - (5) Install four thru bolts (12).
 - (6) Install external fan (2) and locking hub (10).
 - (7) Install fan cover (1) to housing (4) with screws (11).
- c. Lubricate the motor bearings with 1 or 2 shots from a general purpose grease gun.

REPLACEMENT

- a. Refer to paragraph 2-25, and FIGURE 2-15, and install the motor as follows.
 - (1) Position the motor on mounting base (7, FIGURE 2-15).
 - (2) Install motor mounting bolt, nut, and lockwasher assemblies (6). Do not secure until pulleys (3) and (11) are aligned.
 - (3) Align pulleys (3) and (11), install V-belt (2) and adjust tension (paragraph 2-25).
 - (4) Connect electrical wiring to proper terminals in motor terminal box (9, FIGURE 2-16).
- b. Operational check:
 - (1) Turn electrical power ON.
 - (2) Start and run fan to check for proper operation.
 - (3) Remove "Out of Service" tag from circuit.

2-27. Repair Fan, Ventilating (Supply Fan #5) (A/C and Emergency Generator Room). (FIGURE 2-17)

This task covers: a. Removal, b. Repair, c. Replacement.

INITIAL SETUPTools

Tool kit, general mechanic's,
5180-00-699-5273
Tool kit, electrician's,
5180700-391-1087

Materials/Parts

Tag, Item 1, Appendix C
Ventilating fan P/N 71693-8-02
AC electric motor
P/N 34N 57-912
Annular ball bearings P/N 203
Grease, Item 2, Appendix C

Equipment Condition

Circuit breaker switch OFF, power
panel locked and tagged "Out of
Service - Do Not Operate."

See TM 55-1905-223-10 for HVAG systems
operation and equipment location.

REMOVAL**WARNING**

Make sure electrical power is OFF to avoid personal injury.

- a. Remove bolts (1), flat washers (2), and lockwashers (3) and nuts (4) and remove box guard (9, FIGURE 2-17).
- b. Loosen setscrew (10) and remove impeller (8) from motor (5) shaft.
- c. Tag and disconnect wiring from motor (5) terminal box.
- d. Remove the panel (7) with motor (5) from its mounting.

REPAIR

Repair consists of replacing the alternating current motor (5, FIGURE 2-17) or the motor bearings (5, 6, FIGURE 2-16).

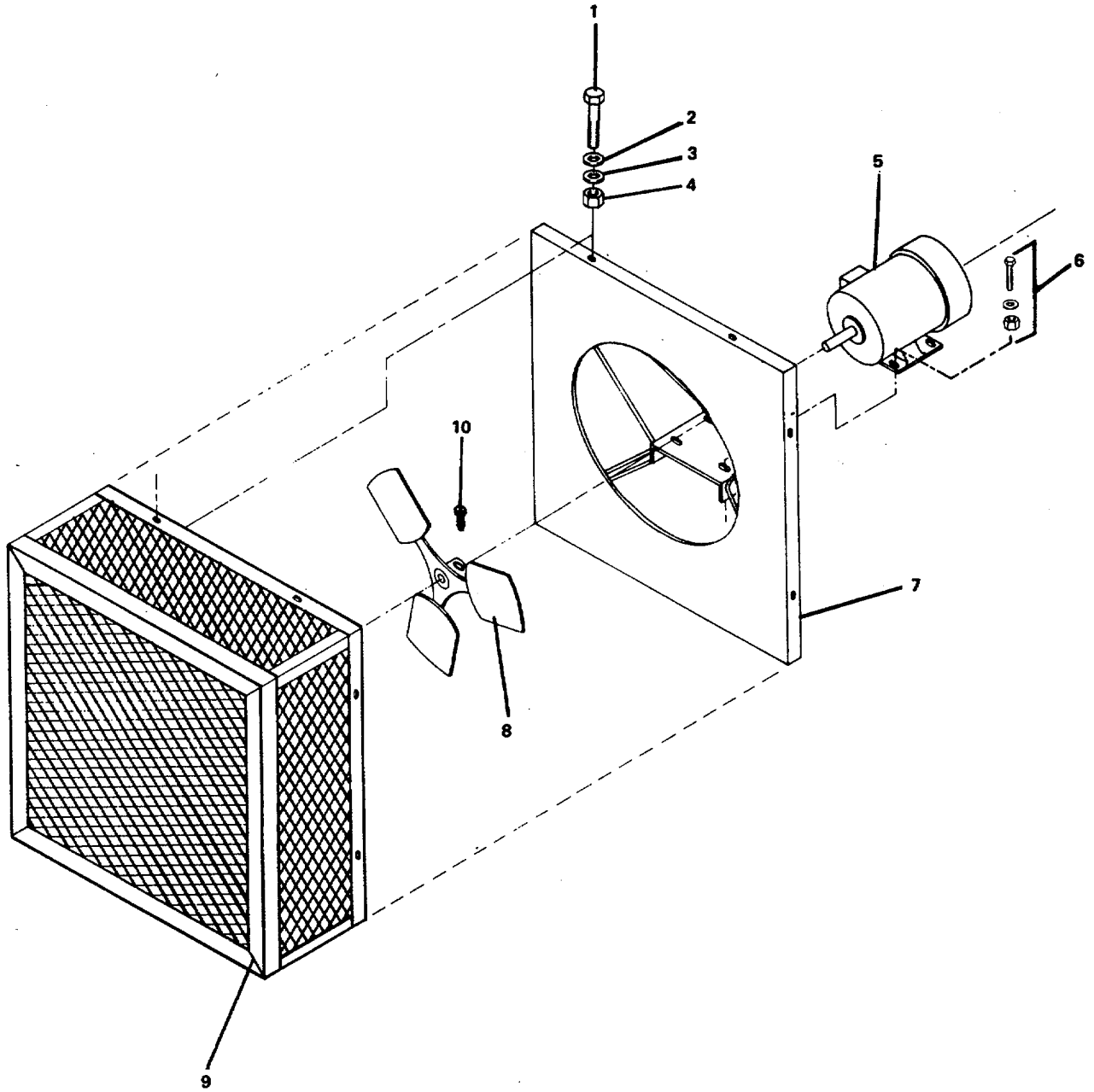

Figure 2-17. Ventilating Fan (Supply Fan #5).

- a. Remove the motor (5, FIGURE 2-17) from panel (7) as follows:
 - (1) Remove bolt, nut, and lockwasher assemblies (6).
 - (2) Remove the motor (5).
- b. The replacement procedures for motor bearings is the same as for Supply Fan #4. Refer to repair procedures in paragraph 2-26 and replace motor bearings.
- c. Install the motor (5, FIGURE 2-17) on panel (7) mounting plate as follows:
 - (1) Position motor on mounting plate.
 - (2) Install mounting bolt, nut, and washer assemblies (6).
 - (3) Tighten bolts firmly.

REPLACEMENT

- a. Position fan and panel assembly in its mounting.
- b. Connect electrical wiring to proper terminals on motor (5).
- c. Install impeller (8) onto motor shaft. Tighten setscrew (10) firmly.
- d. Install box guard (9) on panel (7) and install mounting bolts, flat-washers, lockwashers, and nuts (1, 2, 3, 4).
- e. Make sure the impeller (8) is not touching the guard or panel.
- f. Operational check:
 - (1) Turn electrical power ON.
 - (2) Start and run fan to check for proper operation.
 - (3) Remove "Out of Service" tag from the circuit.

2-28. Repair Fan, Ventilating (Supply Fan #6). (FIGURE 2-18)

This task covers: a. **Adjustment,** b. **Removal,** c. **Repair,** d. **Replacement.**

INITIAL SETUP

Tools

Tool kit, general mechanic's,
5180-00-699-5273
Tool kit, electrician's,
5180-00-391-1087

Materials/Parts

Tag, Item 1, Appendix C
Ventilating fan P/N 717234-01
V-belt P/N 725537-34

Equipment Condition

Circuit breaker switch OFF, power
panel locked and tagged "Out of
Service - Do Not Operate."

See TM 55-1905-223-10 for HVAC systems
operation and equipment location.

WARNING

Make sure electrical power is OFF to avoid personal injury.

ADJUSTMENT

- a. Adjust and align fan and motor pulleys.
 - (1) Remove mounting bolts (11) and remove weather cover (1) for access to belt and motor.
 - (2) Visually check pulley alignment before adjusting V-belt tension. Loosen bolts, nuts, and lockwashers (4) to relieve tension on belt.
 - (a) Make sure motor pulley (9) is aligned properly with fan pulley (7).
 - (b) To align pulleys, loosen the four bolts, nuts, and lockwashers (3) holding the motor (2) to the base plate (10) and adjust the motor as required.
 - (c) When pulleys are aligned, secure bolts, nuts, and lockwashers (3) firmly.
- b. Adjust V-belt tension.

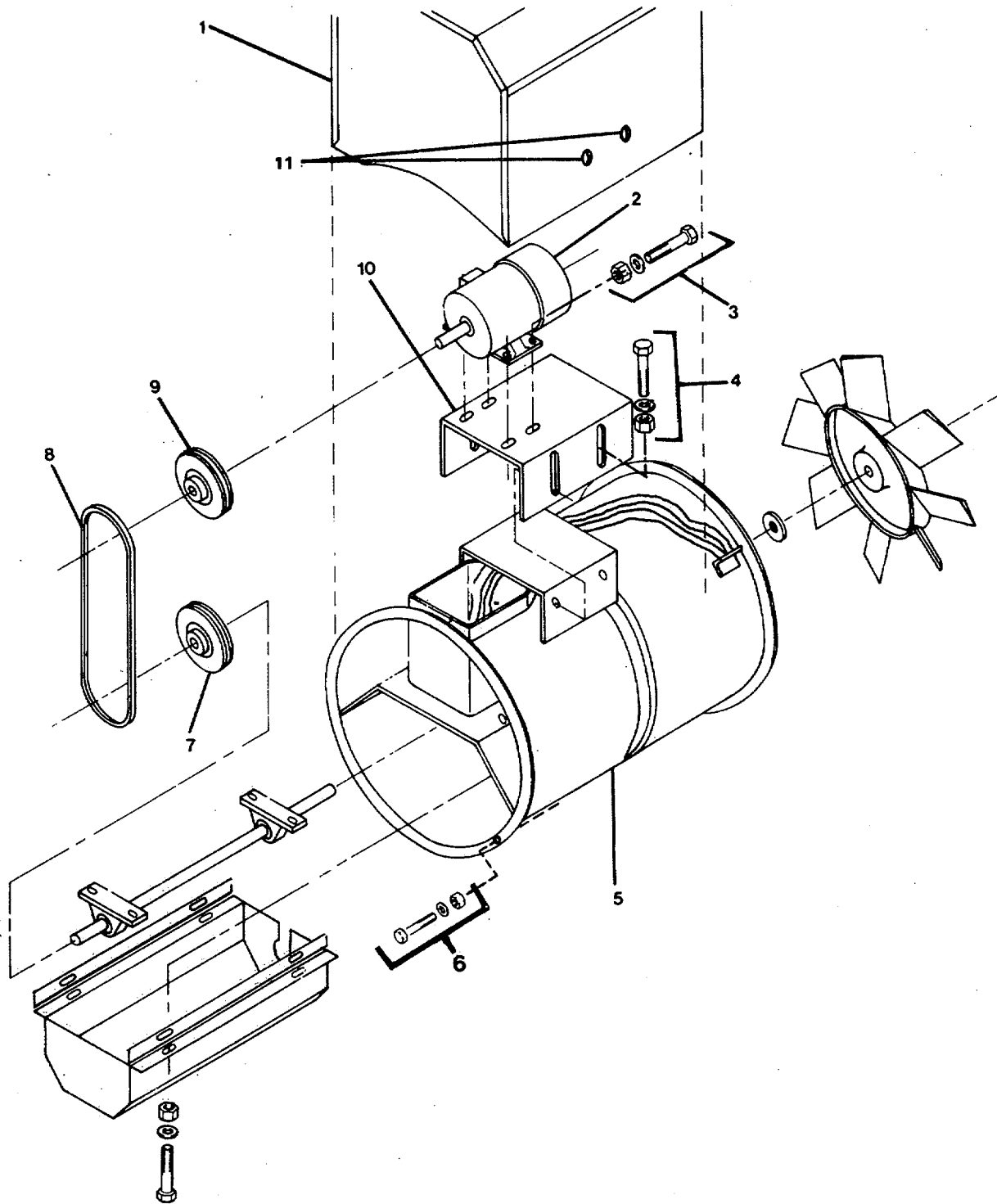

Figure 2-18. Ventilating Fan (Supply Fan #6).

- (1) Remove mounting bolts (11) and remove weather cover (1) for access to belt and motor.
- (2) Loosen the four bolts, nuts, and lockwashers (4).
- (3) Pull back, or out, on motor base plate (10) to increase tension on V-belt (8).
- (4) Keep tension on motor and base while securing bolts, nuts, and washers (4) firmly.
- (5) Install weather cover (1) with mounting bolts (11).

REMOVAL

WARNING

Make sure electrical power is OFF to avoid personal injury.

- a. Remove mounting bolts (11) and weather cover (1).
- b. Tag and disconnect electrical wiring from motor (2).

WARNING

Ensure assembly is supported to keep it from falling during removal.

- c. Support fan assembly and remove mounting (6) hardware from the flange at the end of the fan drum (5).
- d. Remove the fan assembly.

REPAIR

Repair consists of replacing the V-belt (8).

- a. Remove mounting bolts (11) and weather cover (1).
- b. Loosen adjusting bolt, nut, and lockwasher assemblies (4) until base plate (10) slides down, or in, to loosen tension on V-belt (8).
- c. Remove V-belt (8) from around pulley (9) on motor shaft and pulley (7) on fan shaft.
- d. Install new belt (8) on pulleys (7) and (9).
- e. Adjust belt tension. Refer to ADJUSTMENT step in this procedure.

REPLACEMENT

- a. Position and support the fan assembly in place.
- b. Install mounting bolt, washer, and nut assemblies (6) at the end of the fan drum (5).
- c. Adjust belt as required (see ADJUSTMENT step b., above).
- d. Connect electrical wires to their proper terminals on the motor (2).
- e. Install mounting bolts (11) to secure weather cover (1).
- f. Operational check:
 - (1) Turn electrical power ON.
 - (2) Start and run fan to check for proper operation.
 - (3) Remove "Out of Service" tag from circuit.

2-29. Repair Motor, Electric, Alternating Current (Supply Fan #6)

This task covers: a. Removal, b. Repair, c. Replacement.

INITIAL SETUPTools

Tool kit, general mechanic's
5180-00-699-5273
Tool kit, electrician's
5180-00-391-1087
Puller, 5120-00-516-3120

Equipment Condition

Circuit breaker switch OFF, power panel locked and tagged "Out of Service - Do Not Operate."

See TM 55-1905-223-10 for HVAC systems operation and equipment location.

Materials/Parts

Tags, Item 1, Appendix C
Grease, Item 2, Appendix C
AC electric motor
P/N 35J790W321
Bearing P/N 205
Annular ball bearing P/N 203

WARNING

Make sure electrical power is OFF to avoid personal injury.

REMOVAL

- a. Remove weather cover from fan assembly for access to motor (paragraph 2-28).
- b. Tag and disconnect electrical wiring in motor terminal box (9, FIGURE 2-16).
- c. Refer to paragraph 2-28 and FIGURE 2-18, and remove the motor as follows:
 - (1) Loosen tension on V-belt (8). Remove belt from around motor pulley (9, FIGURE 2-18).
 - (2) Remove the motor pulley.
 - (3) Remove motor mounting bolt, nut, and lockwasher assemblies (3).
 - (4) Remove the motor (2) from the motor base (10).

REPAIR

Repair consists of replacing motor bearings. Procedures are the same as those for the motor on Supply Fan #4. Refer to paragraph 2-26 and FIGURE 2-16.

REPLACEMENT

- a. Refer to paragraph 2-28 and FIGURE 2-18, and install the motor as follows:
 - (1) Position the motor (2) on mounting base (10, FIGURE 2-18).
 - (2) Install motor mounting bolt, nut, and lockwasher assemblies (3). Do not secure until pulleys (7) and (9) are aligned.
 - (3) Align pulleys (7) and (9), install V-belt (8) and adjust tension (paragraph 2-28).
 - (4) Connect electrical wiring to proper terminals in motor terminal box (9, FIGURE 2-16).
- b. Install weather cover (1, FIGURE 2-18) with mounting bolts (11).
- c. Operational check:
 - (1) Turn electrical power ON.
 - (2) Start and run fan to check for proper operation.
 - (3) Remove "Out of Service" tag from circuit.

2-29.1. Remove/Replace Fan, Ventilating (Supply Fans #7 & 8). (FIGURE 2-18.1)**This task covers: a. Removal b. Replacement****INITIAL SETUP**Tools

Tool Kit, general mechanic's,
5180-00-699-5273
Tool Kit, electrician's,
5180-00-391-1087

Equipment Condition

Circuit breaker switched OFF at breaker box, power
panel tagged "Out of Service."

See TM 55-1905-223-10 for HVAC systems operation
and equipment location.

Materials/Parts

Tag, Item 1, Appendix C
Ventilating fan,
P/N 500702-4036

REMOVAL

1. Remove the two screws (figure 2-18.1, item 1) from the junction box cover (figure 2-18.1, item 2).
2. Remove the junction box cover (figure 2-18.1, item 2) from the junction box (figure 2-18.1, item 3).



Replace or repair components only after the affected circuit has been secured, locked out, and tagged out (FM 4-01.502, Supersedes FM 55-502). Performing replacement with the circuit energized may result in injury or death.

3. Use a multimeter to check for available voltage at the junction box (figure 2-18.1, item 3). If voltage is present, ensure that the proper circuit breaker is secured, locked out, and tagged out (FM 4-01.502, Supersedes FM 55-502). If no voltage is present, continue with the procedure.
4. Label and disconnect the wiring (figure 2-18.1, item 4) from the junction box (figure 2-18.1, item 3).
5. Remove the eight bolts (figure 2-18.1, item 5), eight flat washers (figure 2-18.1, item 6), and eight nuts (figure 2-18.1, item 7) that secure the ventilating fan (figure 2-18.1, item 8) to the mounting flange (figure 2-18.1, item 9).
6. Remove the ventilating fan (figure 2-18.1, item 8) from the mounting flange (figure 2-18.1, item 9).
7. Remove the eight bolts (figure 2-18.1, item 10), eight flat washers (figure 2-18.1, item 11), and eight nuts (figure 2-18.1, item 12) that secure the bell (figure 2-18.1, item 13) to the ventilating fan (figure 2-18.1, item 8).
8. Remove the bell (figure 2-18.1, item 13) from the ventilating fan (figure 2-18.1, item 8).
9. Remove the four screws (figure 2-18.1, item 14), four flat washers (figure 2-18.1, item 15), and the four nuts (figure 2-18.1, item 16) that secure the bell screen (figure 2-18.1, item 17) to the bell (figure 2-18.1, item 13).
10. Remove the bell screen (figure 2-18.1, item 17) from the bell (figure 2-18.1, item 13).
11. Set the bell screen (figure 2-18.1, item 17) and the bell (figure 2-18.1, item 13) aside for installation on the replacement ventilating fan (figure 2-18.1, item 8).

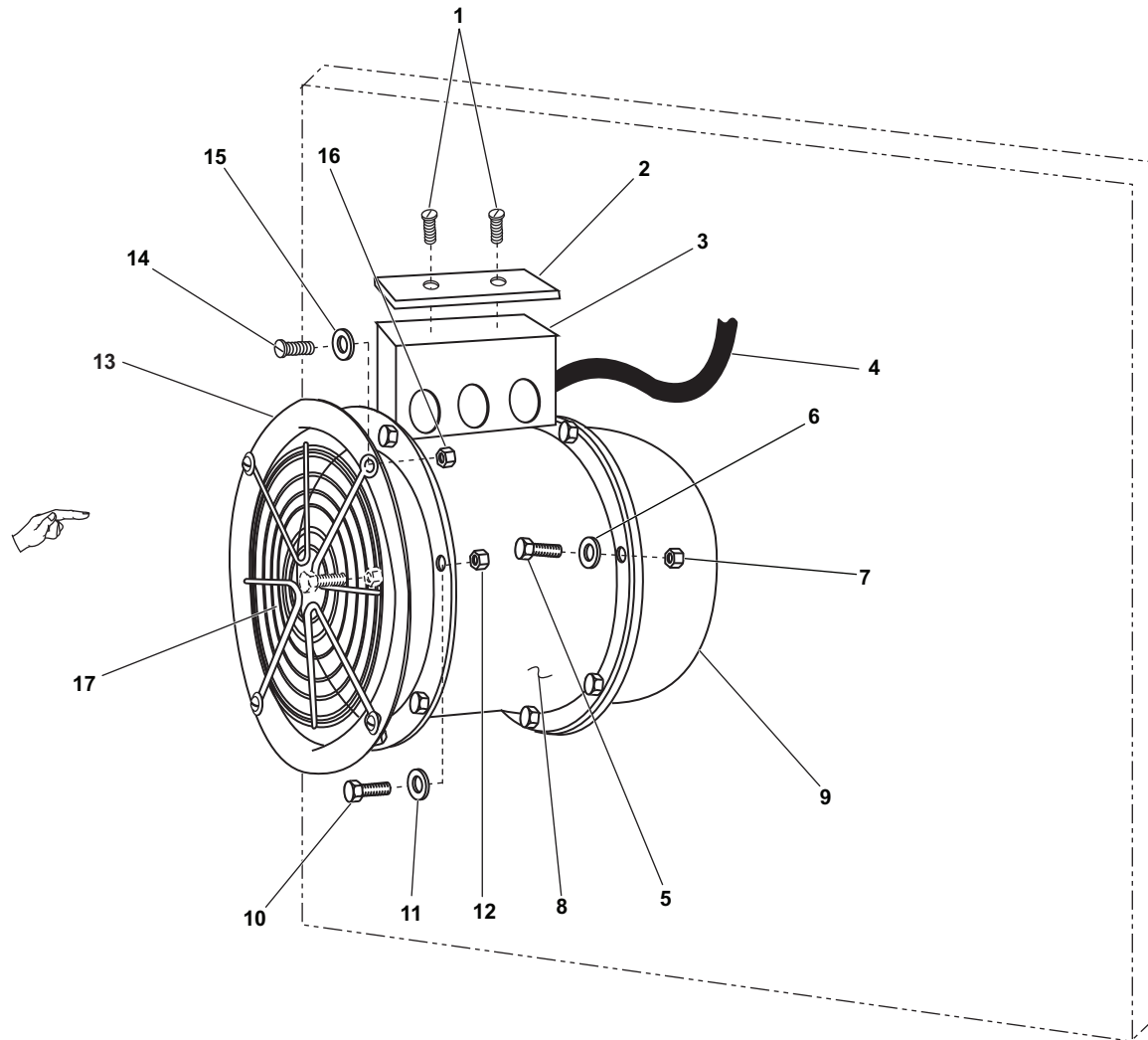

FIGURE 2-18.1. Ventilating Supply Fans #7 & 8.

REPLACEMENT

1. Install the bell screen (figure 2-18.1, item 17) on the bell (figure 2-18.1, item 13).
2. Install the four screws (figure 2-18.1, item 14), four flat washers (figure 2-18.1, item 15), and the four nuts (figure 2-18.1, item 16) that secure the bell screen (figure 2-18.1, item 17) to the bell (figure 2-18.1, item 13).
3. Install the bell (figure 2-18.1, item 13) on the ventilating fan (figure 2-18.1, item 8).
4. Install the eight bolts (figure 2-18.1, item 10), eight flat washers (figure 2-18.1, item 11), and eight nuts (figure 2-18.1, item 12) that secure the bell (figure 2-18.1, item 13) to the ventilating fan (figure 2-18.1, item 8).
5. Install the ventilating fan (figure 2-18.1, item 8) on the mounting flange (figure 2-18.1, item 9).

6. Install the eight bolts (figure 2-18.1, item 5), eight flat washers (figure 2-18.1, item 6), and eight nuts (figure 2-18.1, item 7) that secure the ventilating fan (figure 2-18.1, item 8) to the mounting flange (figure 2-18.1, item 9).
7. Connect the wiring (figure 2-18.1, item 4) in the junction box (figure 2-18.1, item 3) using the labels from step 4 of Removal as a guide. Remove the labels.
8. Install the junction box cover (figure 2-18.1, item 2) on the junction box (figure 2-18.1, item 3).
9. Install the two screws (figure 2-18.1, item 1) in the junction box cover (figure 2-18.1, item 2).
10. Remove the lockouts and tagouts (FM 4-01.502, Supersedes FM 55-502).
11. Operate the ventilating fan (figure 2-18.1, item 8) under usual conditions (TM 55-1905-223-10) and check for proper operation.
12. Return the ventilating fan (figure 2-18.1, item 8) to the desired readiness condition.

2-30. Repair Fan, Ventilating (Exhaust Fan #3) (Steering Gear Room).

This task covers: a. Removal, b. Repair, c. Replacement.

INITIAL SETUPTools

Tool kit, general mechanic's,
5180-00-699-5273
Tool kit, electrician's,
5180-00-391-1087

Materials/Parts

Tags, Item 1, Appendix C
Grease, Item 2, Appendix C
Ventilating fan P/N 717293-10
AC electric motor
P/N 35J788Y605
Annular ball bearing P/N 203
Bearing P/N 205

Equipment Condition

Circuit breaker switch OFF, power
panel locked and tagged "Out of
Service - Do Not Operate."

See TM 55-1905-223-10 for HVAC systems
operation and equipment location.

REMOVAL**WARNING**

Make sure electrical power is OFF to avoid personal injury.

- a. Tag and disconnect electrical wiring from conduit box (2, FIGURE 2-19).
- b. Support the fan assembly and remove mounting bolt, nut, and washer assemblies (8) from bulkhead end of the fan drum (7).
- c. Remove the fan assembly.

REPAIR

Repair consists of replacing the electric motor or the motor bearings.

- a. Removal of motor:
 - (1) Remove screen (3) by removing bolts (4), washers (5) and nuts (6).

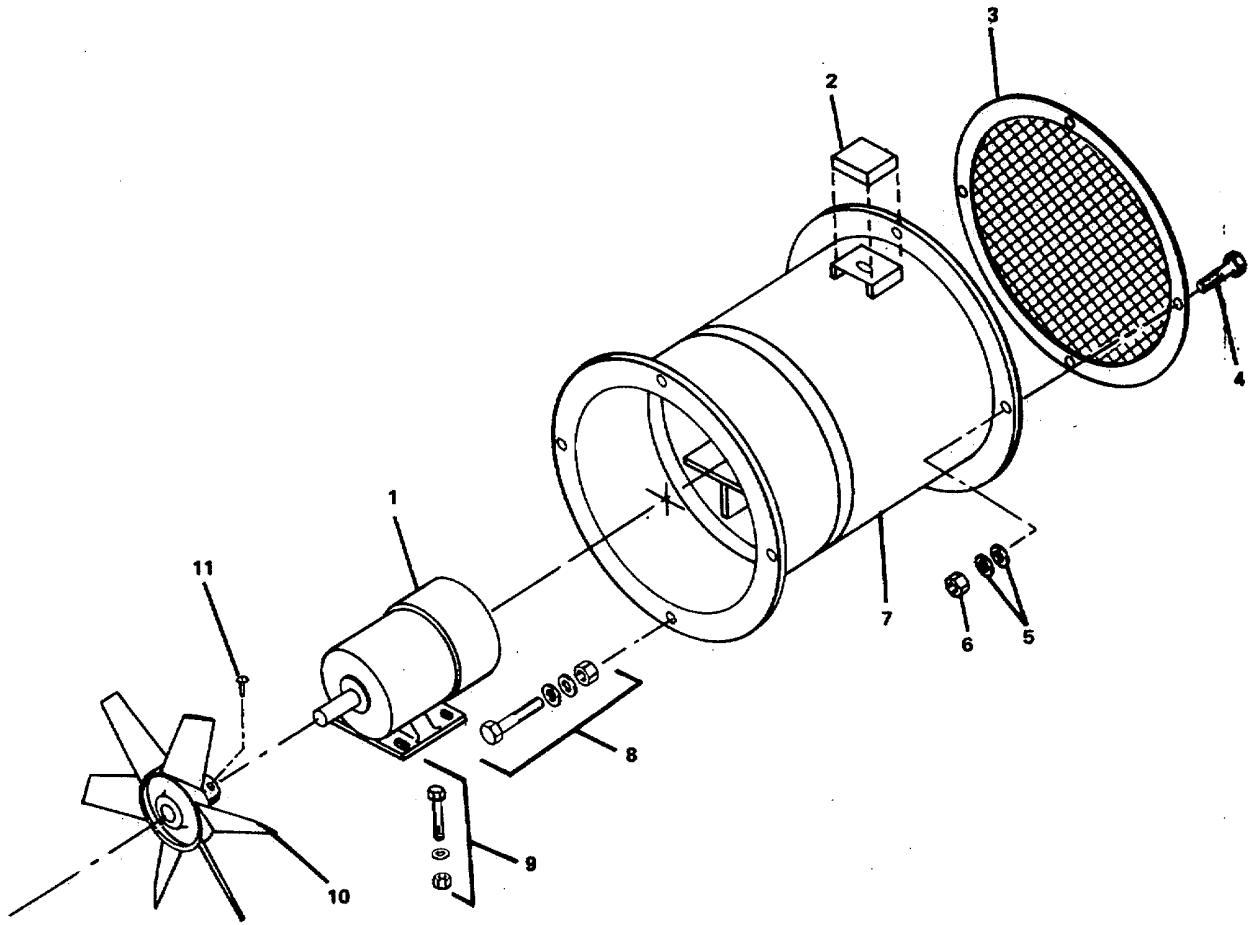

Figure 2-19. Ventilating Fan (Exhaust Fan #3).

- (2) Tag and disconnect electrical wiring from terminal box (9, FIGURE 2-20).
- (3) Loosen setscrew (11, FIGURE 2-19) and remove the impeller (10) from the shaft of the motor (1).
- (4) Remove mounting bolt, nut, and washer assemblies (9).
- (5) Withdraw the motor (1) from the fan drum (7).

b. Removal of bearings (refer to FIGURE 2-20):

- (1) Remove screws (11) and fan cover (1) from motor housing (4).

NOTE

Place reference marks on end plates (3) and (7) and housing for reinstallation alignment.

- (2) Remove locking hub (10), external fan (2), thru bolts (12), and end plates (3) and (7).
- (3) Remove rotor (8) from motor housing (4).
- (4) Remove annular ball bearing (5) from non-drive end of the rotor (8) with a puller.
- (5) Remove bearing (6) from drive shaft with a puller.

c. Replacement of bearings (refer to FIGURE 2-20):

- (1) Install new bearing (6) onto drive shaft with a press.
- (2) Install new annular ball bearing (5) onto non-drive end of the rotor (8) with a press.
- (3) Position the rotor (8) in the motor housing (4).

NOTE

Align end plates (3) and (7) using marks previously made during disassembly.

- (4) Install end plates (3) and (7).
- (5) Install four thru bolts (12), external fan (2), and locking hub (10).
- (6) Install fan cover (1), and screws (11).

d. Lubricate the motor bearings with 1 or 2 shots from a general purpose grease gun.

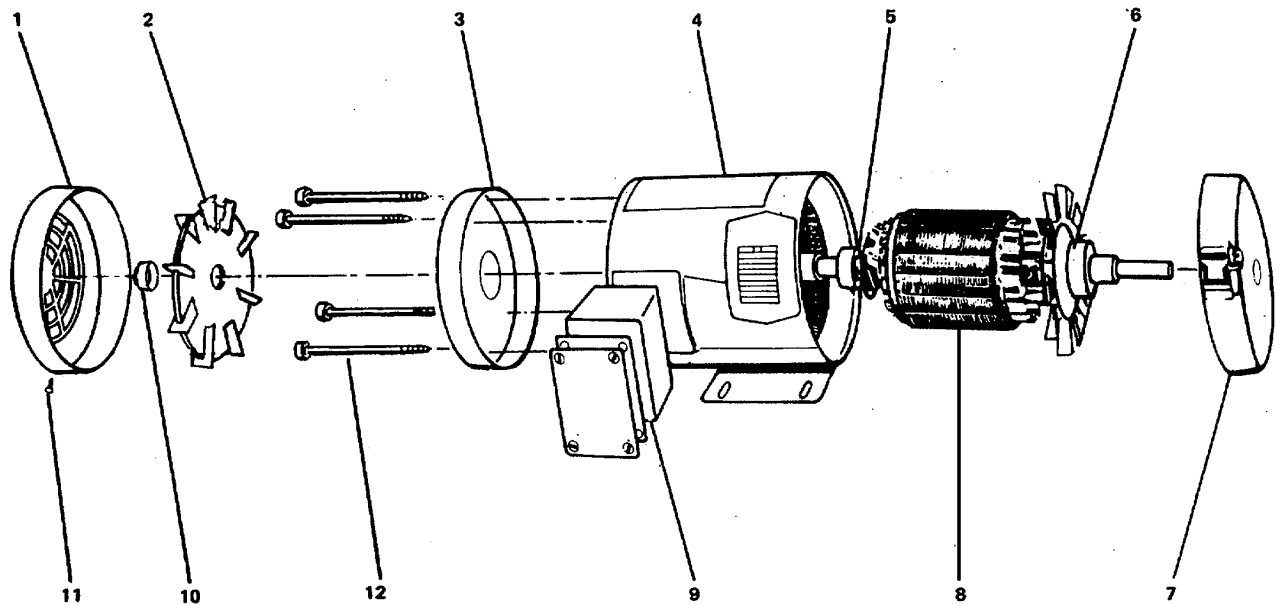

Figure 2-20. *Alternating Current Electric Motor (EF #3).*

- e. Replacement of motor (refer to FIGURE 2-19):
- (1) Position the motor (1) on its mounting surface in the fan drum (7).
 - (2) Install mounting bolt, nut, and washer assemblies (9). Secure bolts firmly.
 - (3) Install impeller (10) onto shaft of motor (1). Tighten setscrew (11) firmly.
 - (4) Connect the electrical wires to terminal box on motor.
 - (5) Install screen (3) with nuts (6), washers (5), and bolts (4).

REPLACEMENT

- a. Position the fan and install mounting bolt, nut, and washer assemblies (8, FIGURE 2-19) in bulkhead end of the fan drum (7). Secure bolts firmly.
- b. Connect wiring to conduit box (2).
- c. Operational check:
 - (1) Turn electrical power ON.
 - (2) Start and run fan to check operation.
 - (3) Remove "Out of Service" tag from circuit.

2-31. Repair Fan, Ventilating (Exhaust Fans #4 and #6)..(FIGURE 2-20)

This task covers:

- a. Adjustment b. Removal c. Repair d. Replacement

INITIAL SETUP:

Tools

Tool kit, general mechanic's,
5180-00-699-5273
Tool kit, electrician's,
5180-00-391-1087
Puller, 5120-00-516-3120
Hydraulic Press PN 2009-13

Equipment Condition

Circuit breaker switch OFF, power panel
locked and tagged "Out of Service -
Do Not Operate."

See TM 55-1905-223-10 for HVAC systems
operation and equipment location.

Materials/Parts

Tags, Item 1, Appendix C
Grease, Item 2, Appendix C
Exhaust Fan 4
Ventilating fan P/N 1000-88-01
AC motor 34N58-900
V-belt P/N 725469-51
Fan sheave P/N 725334-07
Bearing P/N 203
Bearing P/N 205
Exhaust Fan 6
Ventilating fan P/N 1008-88-02
AC motor P/N 1-1/2HP-1800-240/3TE
V-belt P/N 725537-50
Fan sheave P/N 725334-02
Bearing P/N 203
Bearing P/N 205

ADJUSTMENT

WARNING

Make sure electrical power is OFF to avoid personal injury.

- a. Adjust and align fan and motor sheaves.

(1) Remove screws (17) and remove weather cover (1) for access to belt and motor.

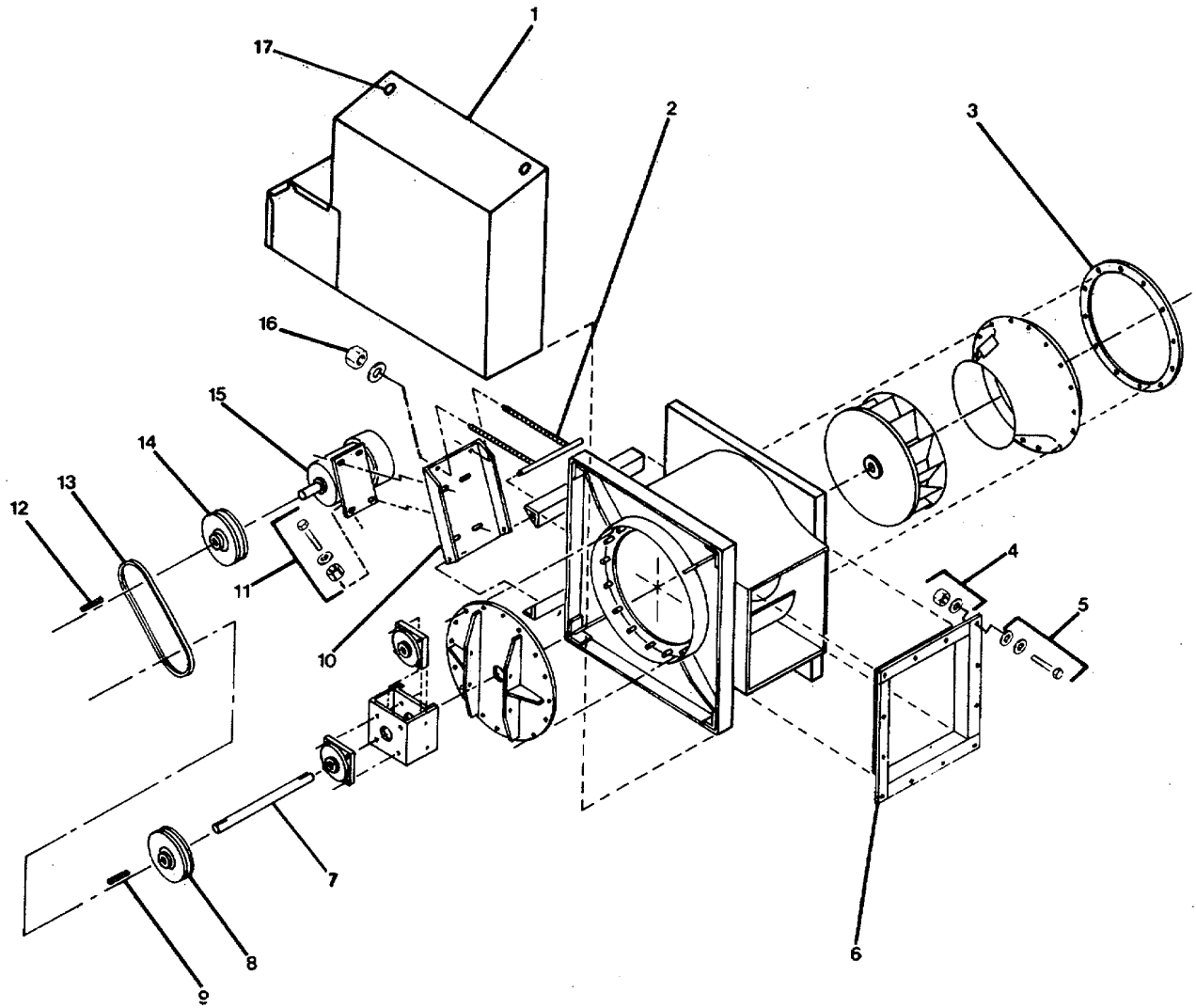

Figure 2-21. Ventilating Fan (Exhaust Fans #4 and #6).

- (2) Visually check alignment (14) before adjusting V-belt tension. Loosen nuts (16) on the adjusting studs (2) to relieve tension on belt (13).
 - (a) Make sure motor sheave (14) is aligned properly with fan sheave (8).
 - (b) To align sheaves, loosen the four bolts and nuts (11) holding the motor (15) to the base plate (10) and adjust the motor as required.
 - (c) When sheaves are aligned, secure bolts and nuts (11) firmly.
- b. Adjust V-belt tension.
 - (1) Remove weather cover (1) for access to belt and motor if not already removed.
 - (2) Loosen the two adjusting nuts (16) on adjusting studs (2).
 - (3) Pull back, or out, on the top of motor base plate (10) to increase tension on V-belt (13).
 - (4) Keep tension on motor and base while securing nuts (16).
 - (5) Secure adjusting (16) firmly on adjusting studs (2).
 - (6) Install weather cover (1) with screws (17).

REMOVAL

WARNING

Make sure electrical power is OFF to avoid personal injury.

- a. Remove screws (17) and remove weather cover (1).
- b. Tag and disconnect electrical wiring from motor (15).
- c. Disconnect inlet flange (3) from ducting.
- d. Remove nut, bolt, and washer assemblies (4, 5) and disconnect outlet flange (6) from ducting.
- e. Remove fan assembly.

REPAIR

Repair consists of replacing the V-belt (13), fan sheave (8), electric ac motor (15), and motor bearings.

- a. Remove screws (17) and remove weather cover (1).

b. Replace V-belt:

- (1) Loosen adjusting nuts (16) and push base plate (10) in, or towards housing, to relieve tension on V-belt (13).
- (2) Remove V-belt (13) from around motor sheave (14) and fan sheave (8). Discard V-belt.
- (3) Install a new V-belt on sheaves (8) and (14).
- (4) Adjust belt tension. Refer to ADJUSTMENT procedures in this paragraph.

c. Replace fan sheave:

- (1) Remove V-belt (13) (REPAIR, step b., above).
- (2) Use a puller and remove fan sheave (8) and machine key (9) from straight shaft (7).
- (3) Position machine key (9) in straight shaft spline and install new fan sheave (8) onto the shaft with a hydraulic press.
- (4) Install the V-belt (13) (REPAIR, step b. above).

d. Replace alternating current electric motor (15):

- (1) Remove motor as follows:
 - 1 Tag and disconnect electrical wiring from motor (15).
 - 2 Remove V-belt (13) (REPAIR, step b.).
 - 3 Use a puller and remove sheave (14) and key (12) from motor shaft.
 - 4 Remove motor mounting bolt, nut, and washer assemblies (11).
 - 5 Remove motor (15) from base plate (10).
- (2) Install motor as follows:
 - 1 Position motor (15) on base plate (10) and install mounting bolt, nut and washer assemblies (11). Do not secure bolts until motor sheave (14) is installed and aligned.
 - 2 Install key (12) and pulley (14) onto motor shaft with a hydraulic press.
 - 3 Align motor pulley (14) with fan pulley (8).
 - 4 Secure bolt, nut, and washer assemblies (11) firmly.
 - 5 Install V-belt (13) (REPAIR, step b. above).

e. Replace motor bearings:

- (1) Remove electric motor from fan (REPAIR, step d., above).
- (2) The procedures for replacing motor bearings are the same as those for Exhaust Fan #3. Refer to REPAIR, steps b. through d., paragraph 2-29.
- (3) Install motor (REPAIR, step d., above).
- (4) Connect electrical wiring to proper terminals on motor (15, FIGURE 2-21).

REPLACEMENT

- a. Position fan and connect outlet flange (6) to ducting with nut, bolt, and washer assemblies (4, 5).
- b. Connect inlet flange (3) to ducting.
- c. Connect electrical wiring to proper terminals on motor (15).
- d. Install weather cover (1) with screws (17).
- e. Operational check:
 - (1) Turn electrical power ON.
 - (2) Start and run fan to check for proper operation.
 - (3) Remove "Out of Service" tag from circuit.

2-32. Repair Fan, Ventilating (Exhaust Fan #7)..(FIGURE 2-22)

This task covers:

- a. Removal b. Repair c. Replacement

INITIAL SETUP:

Tools

Tool kit, general mechanic's,
5180-00-699-5273
Tool kit, electrician's,
5180-00-391-1087

Equipment Condition

Circuit breaker switch OFF, power panel
locked and tagged "Out of Service -
Do Not Operate."

See TM 55-1905-223-10 for HVAC systems
operation and equipment location.

Materials/Parts

Tags, Item 1, Appendix C
Ventilating fan P/N 879030-06
Explosion-proof motor
P/N 1HP-860230/3-ISP

REMOVAL

WARNING

Make sure electrical power is OFF to avoid personal injury.

- a. Tag and disconnect electrical wiring from terminal box on motor (8).
- b. Disconnect housing (1) at inlet flange (3) and outlet flange (4).
- c. Remove mounting screws (6) from drive support (5) and remove fan assembly.

REPAIR

Repair consists of replacing the explosion-proof motor (8).

- a. Remove motor:
 - (1) Remove nuts (9) from studs (10) to detach drive support (5) from housing (1).
 - (2) Loosen the blower wheel (2) on the shaft of the motor (8). Slide the blower wheel off the motor shaft. Slide drive support, motor, and blower wheel assembly from housing.

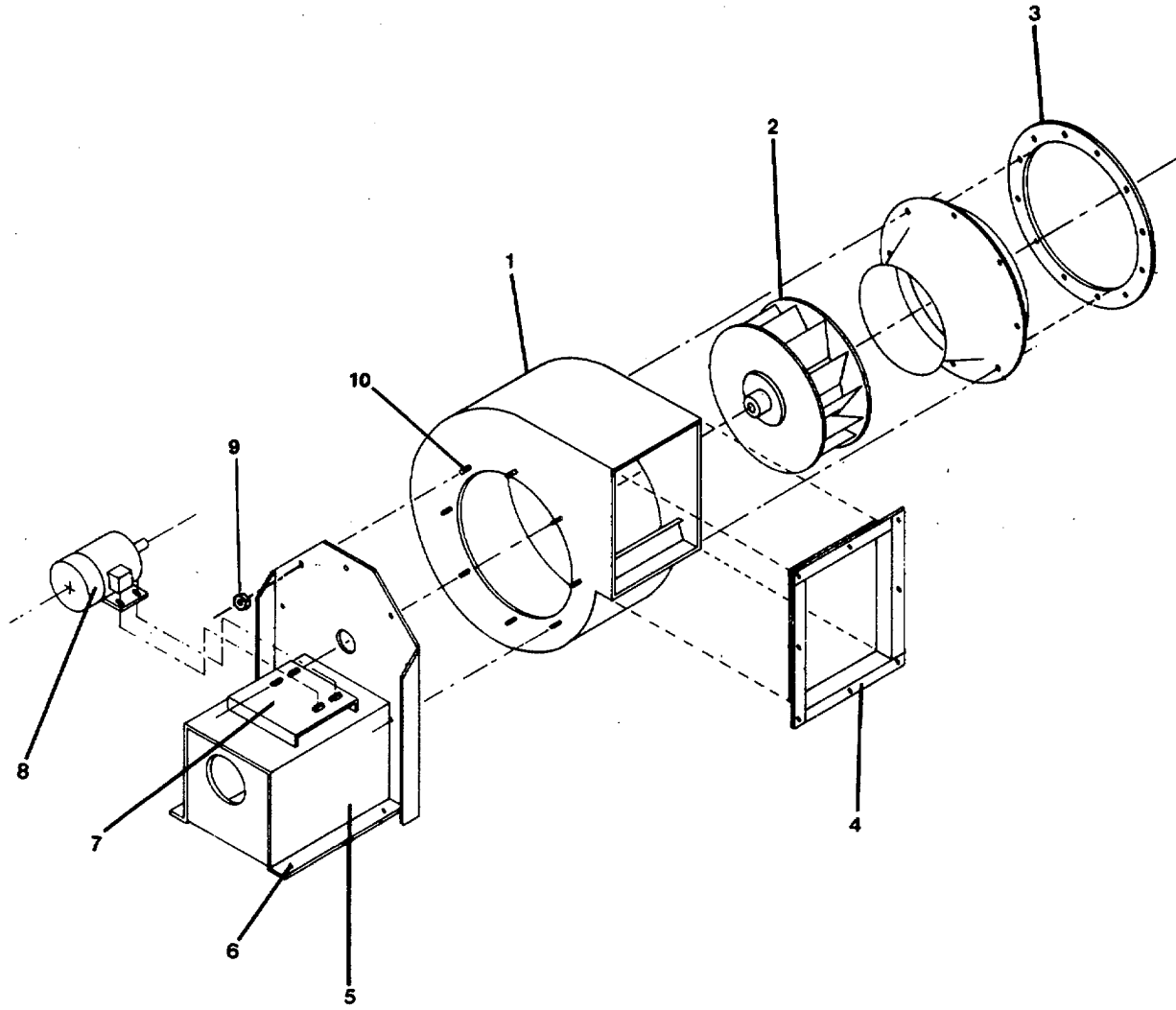

Figure 2-22. Ventilating Fan (Exhaust Fan #7).

- (3) Remove the mounting bolts that hold the motor to the plate (7) on the drive support (5).
 - (4) Remove motor (8).
- b. Replace motor:
- (1) Position motor (8) on plate (7) and install motor mounting hardware.
 - (2) Install blower wheel (2) onto shaft of motor (8). Tighten setscrew firmly.
 - (3) Turn blower wheel by hand to make sure it is not rubbing against housing components. Re-adjust wheel on motor shaft as required to prevent rubbing.

REPLACEMENT

- a. Install the fan with the drive support (5) mounting screws (6).
- b. Connect electrical wiring to proper terminals on motor (8).
- c. Connect housing (1) at inlet flange (3) and outlet flange (4).
- d. Operational check:
 - (1) Turn electrical power ON.
 - (2) Start and run fan to check for proper operation.
 - (3) Remove "Out of Service" tag from circuit.

2-33. Repair Air Conditioner (A/C #1, Pilothouse) and (A/C #3, Engine Control Room)...(FIGURE 2-23)

This task covers:

a. Repair

INITIAL SETUP:

Tools

Tool kit, general mechanic's
5180-00-699-5273

Materials/Parts

Tag, Item 1, Appendix C
Air filter P/N 030-A-052
Liquid detergent, Item 3, Appendix C
Light oil, Item 4, Appendix C

Equipment Condition

Pilothouse air conditioner (A/C #1) or
engine control room air conditioner
(A/C #3) circuit breaker switched
OFF, power panel locked and tagged
"Out of Service - Do Not Operate."

See TM 55-1905-223-10 for HVAC systems
operation and equipment location.

REPAIR

Repair consists of cleaning or replacing the air filter.

WARNING

Turn electrical power OFF to avoid personal injury.

a. Remove air filter:

- (1) Filter is located in the upper, rear portion of the unit.
- (2) Slide filter (1) from retaining rails (2) on the rear of the unit (3).
- (3) Clean or replace as required.

b. Clean filter:

- (1) Soak filter in warm water with a liquid detergent.
- (2) Rinse thoroughly with water. Shake filter gently to remove excess water.
- (3) Apply a mist of light lubricating oil to the side of the filter facing out from the air conditioner.

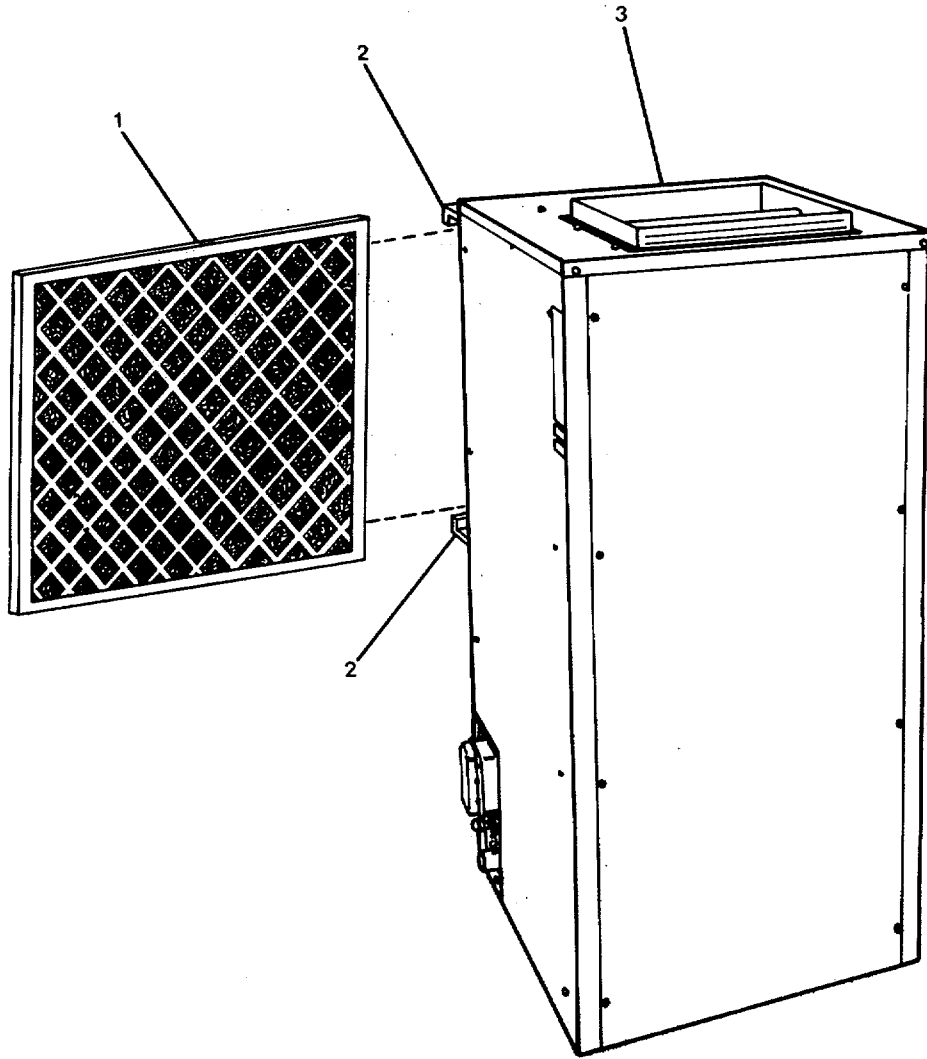

Figure 2-23. Air Conditioner (A/C #1 and A/C #3).

- c. If filter is heavily clogged and cannot be thoroughly cleaned, or if it is bent, crushed, or torn, replace with new filter.
 - (1) Apply a mist of light lubricating oil to the side of the filter facing out from the air conditioner.
 - (2) Slide filter (1) into retaining rails (2) on the rear of the unit (3).
 - (3) Make sure filter is properly positioned to avoid dust being pulled around the filter and into the cooling coil (evaporator).
- d. Turn electrical power ON and remove "Out of Service" tag from circuit.

2-34. Repair Air Conditioner (A/C #2, Accommodations).

This task covers:

a. Repair

INITIAL SETUP:

Tools

Tool kit, general mechanic's,
5180-00-699-5273

Materials/Parts

Tag, Item 1, Appendix C
V-belt P/N LSL-106-2
Air filters (6)
P/N 16 x 20 x 2

Equipment Condition

Accommodations air conditioner
circuit breaker switched OFF,
power panel locked and tagged
"Out of Service - Do Not Operate."

See TM 55-1905-223-10 for HVAC systems
operation and equipment location.

REPAIR

Repair consists of replacing V-belts and air filters.

WARNING

Make sure electrical power is OFF to avoid personal injury.

a. Replace the two V-belts:

- (1) Remove five screws (8, FIGURE 2-24) and remove belt guard (5) from corner of upper cabinet (7).
- (2) Loosen adjusting nuts (1) to release tension on V-belts (4). This will lower the motor (2).
- (3) Remove V-belts from around motor sheave (3) and blower sheave (6). Discard belts.
- (4) Install new V-belts (4) around blower sheave (6) and motor sheave (3).
- (5) Turn adjusting nuts (1) to move the motor (2) upward and tighten the V-belt.
- (6) Install the guard (5) to the upper cabinet (7) with screws (8).

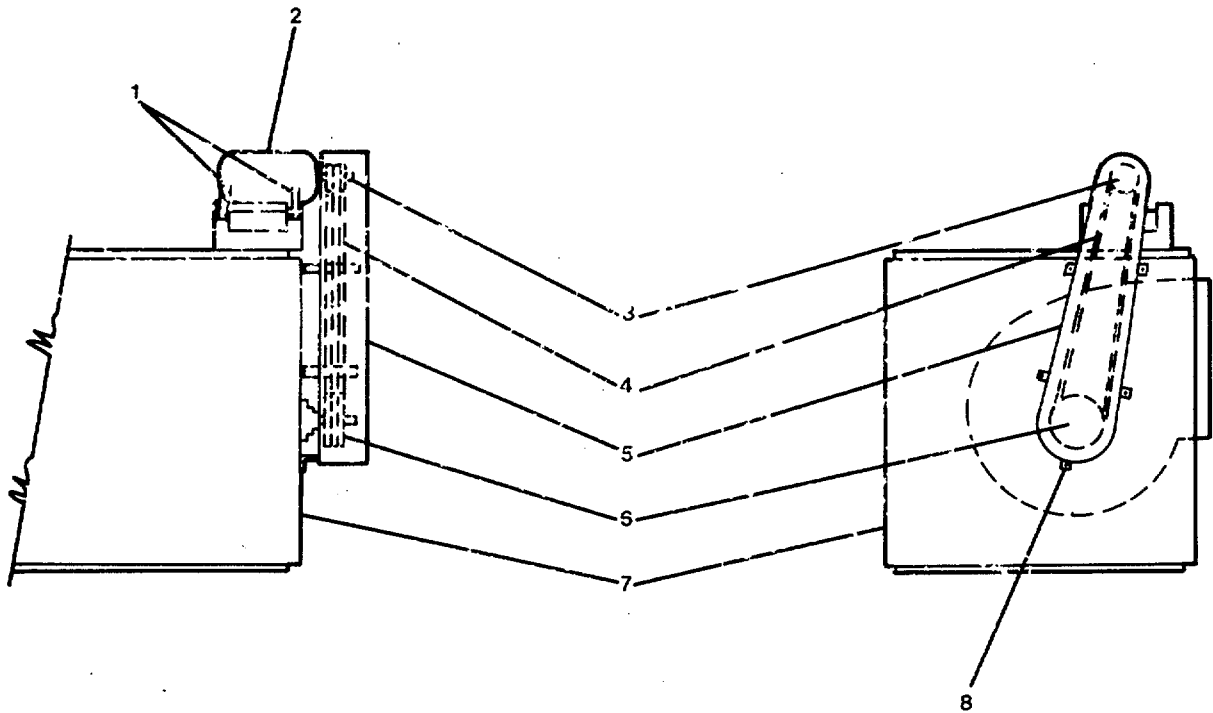

Figure 2-24. Motor and V-Belt Assembly (A/C #2).

WARNING

Make sure electrical power is OFF to avoid personal injury.

b. Replace air filters:

- (1) Open access door (2, FIGURE 2-25) in the upper cabinet (1). The door is on the same side of the unit as the motor and guard (5, 4).
- (2) Slide the six filters (3) from racks inside cabinet. Discard filters.
- (3) Install new filters (3). Make sure they are properly positioned in the racks.
- (4) Close access door (2).

c. Turn electrical power ON and remove "Out of Service" tag from circuit.

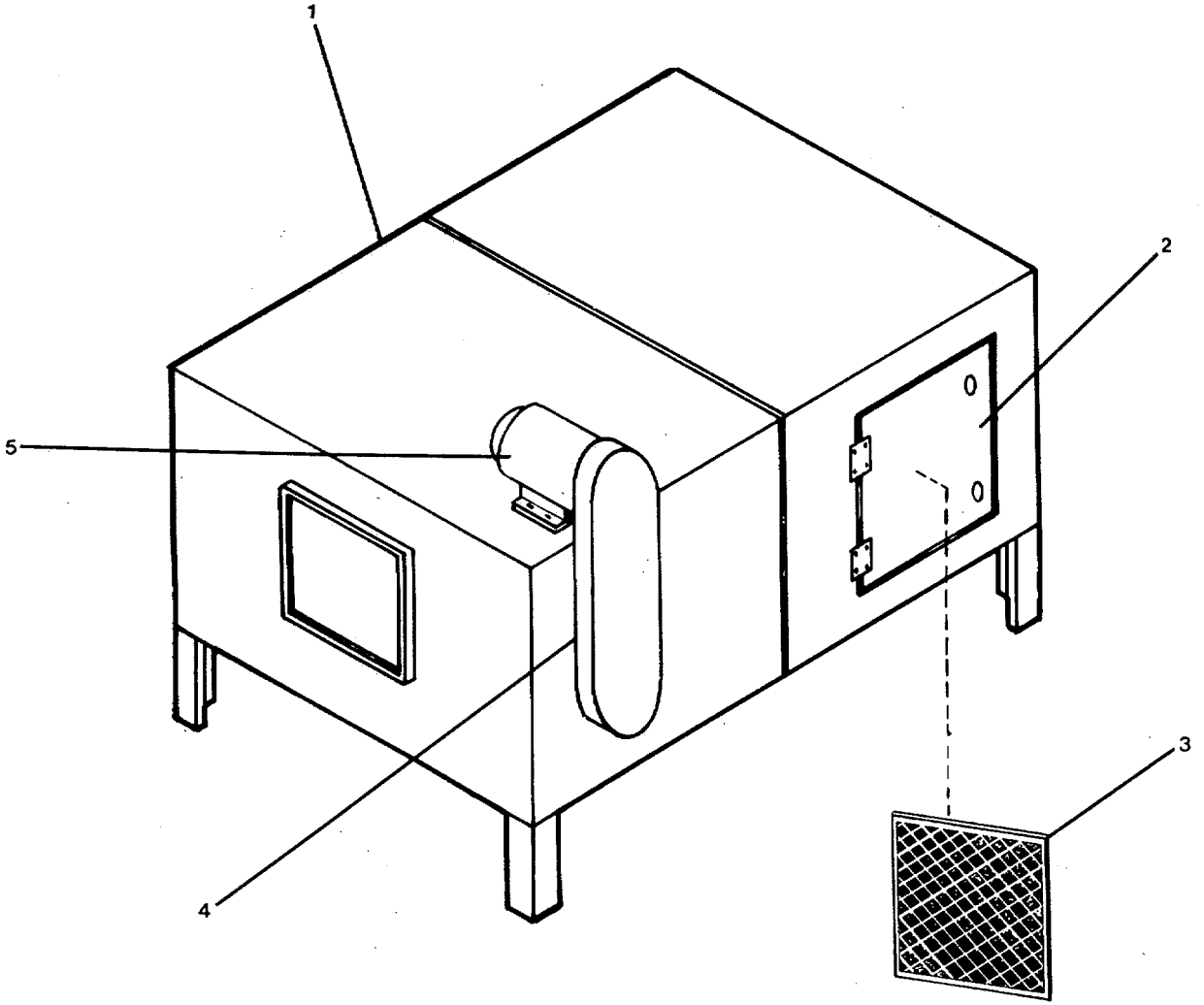

Figure 2-25 . Air Conditioner Upper Cabinet (A/C #2).

2-35. Repair Motor, Electric (A/C #2, Accommodations)

This task covers:

a. **Repair**

INITIAL SETUP:

Tools

Tool kit, general mechanic's,
5180-00-699-5273
Tool kit, electrician's,
5180-00-391-1087
Puller, 5120-00-516-3120
Hydraulic Press PN 2009-13

Equipment Condition

Circuit breaker switch OFF,
power panel locked and tagged
"Out of Service - Do Not Operate."
Belt guard and V-belt removed,
para. 2-34.
Electric motor removed (para. 4-15).

Materials/Parts

Tag, Item 1, Appendix C
Bearing P/N P4881
Bearing P/N P4879

See TM 55-1905-223-10 for HVAC systems
operation and equipment locations.

REPAIR

Repair consists of replacing motor bearings.

WARNING

Make sure electrical power is OFF to avoid personal injury.

- a. Use a puller and remove sheave (3, FIGURE 2-26) and key (2) from motor (1) shaft.
- b. Remove four screws (6, FIGURE 2-27) and remove end cover (7).
- c. Remove four screws (8) and remove end cover (1).
- d. Slide rotor (9) from motor housing (4).
- e. Use a puller and remove bearings (5) and (6) from shaft.
- f. Use a hydraulic press and install new bearings (5) and (6) onto shaft.
- g. Install key (2, FIGURE 2-26) and sheave (3) on shaft of motor (1).

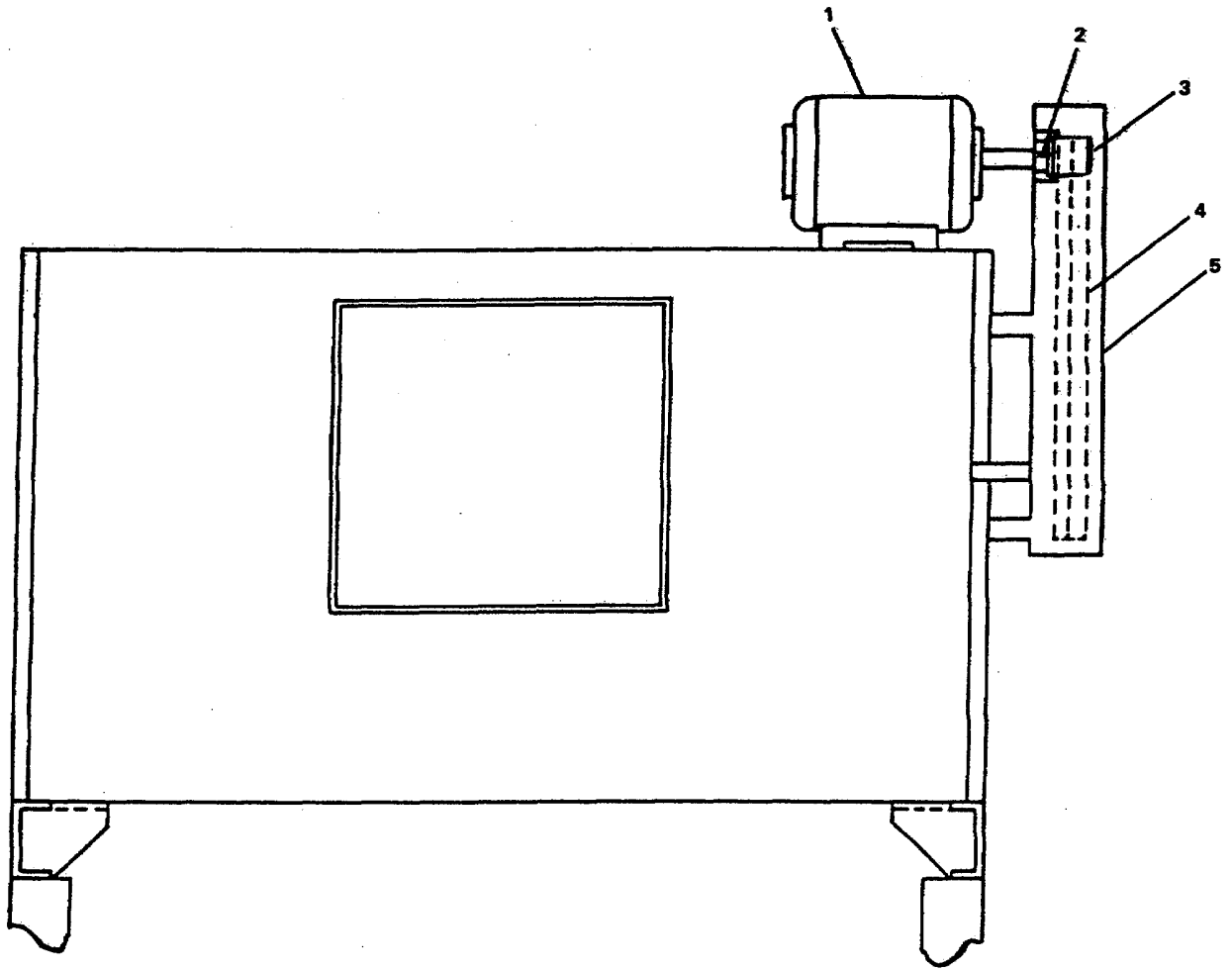

Figure 2-26. Electric Motor (A/C-2).

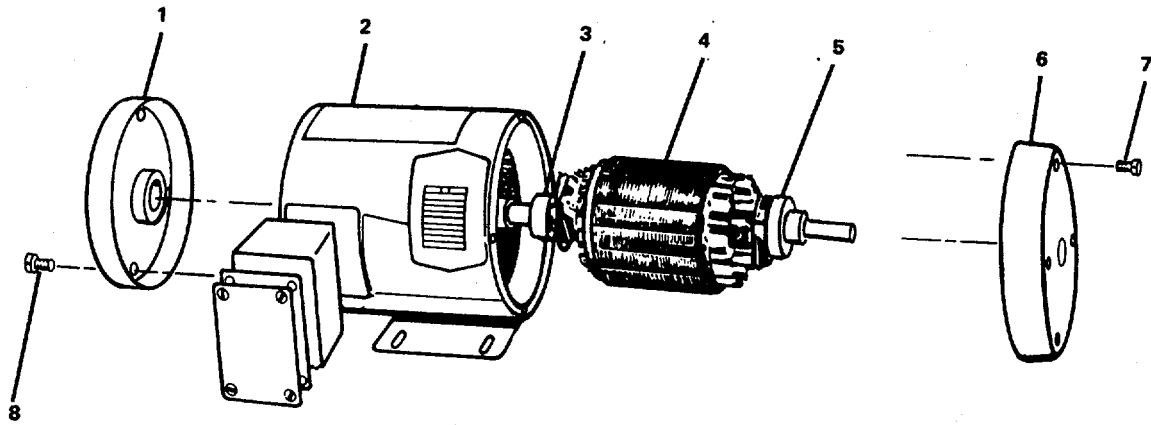

Figure 2-27. Electric Motor (A/C-2).

- h. Install motor (paragraph 4-14).
- i. Install belts and guard (paragraph 2-34).
- j. Operational check:
 - (1) Turn electrical power ON.
 - (2) Start and run motor to check for proper operation.
 - (3) Remove "Out of Service" tag from circuit.

2-36. Replace Condenser, Refridgerating Water Cooled...(FIGURE 2-28)

This task covers:

- a. Removal b. Replacement
-

INITIAL SETUP:Tools

Tool kit, general mechanic's,
5180-00-699-5273
Tool kit, refrigeration and
air conditioning,
5180-00-596-1474

Equipment Condition

Circuit breaker switch OFF,
power panel locked and tagged
"Out of Service - Do Not Operate."

See TM 55-1905-223-10 for HVAC systems
operation and equipment locations.

Materials/Parts

Tag, Item 1, Appendix C
Condenser, Refridgerating
PN SW 18 3/4 M3 3/4

REMOVAL**WARNING**

Make sure electrical power is OFF and circuit tagged out-of-service.

- a. Remove all refrigerant from system.
- b. Close external seawater inlet valve to condenser.
- c. Drain condenser and close external seawater outlet valve.
- d. Disconnect (unsolder) the following lines from the condenser (1).
 - (1) Refrigerant inlet line connection (2).
 - (2) Seawater outlet line connection (3).
 - (3) Seawater inlet line connection (5).
 - (4) Refrigerant outlet line connection (6).
- e. Cover the ends of piping with rags to keep dirt and debris from entering until condenser is installed.

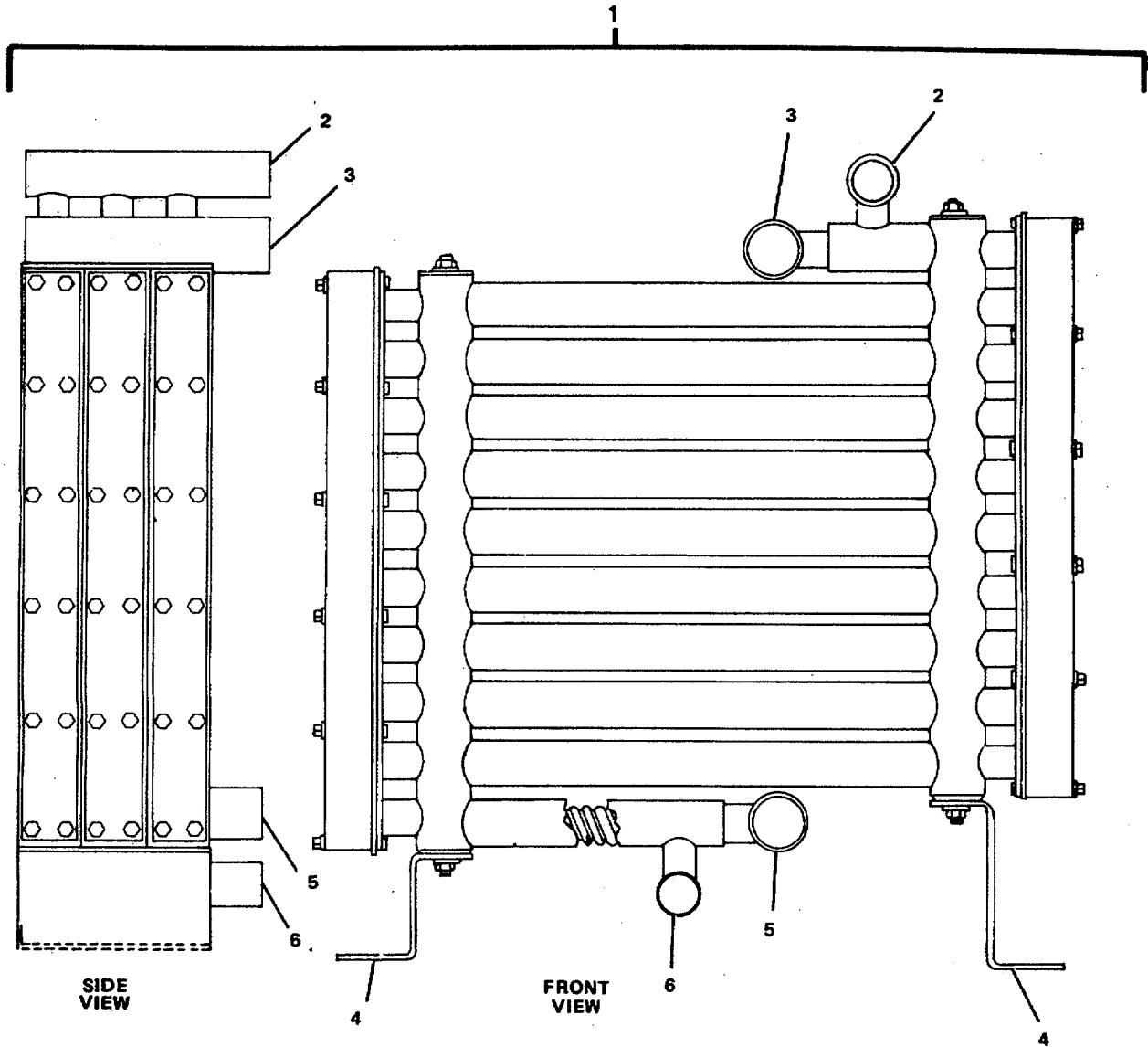

Figure 2-28. Condenser Unit (A/C-2 Accommodations).

- f. Remove the mounting hardware from each steel leg (4) and remove the condenser (1).

REPLACEMENT

- a. Remove temporary pipe coverings (rags) and clean the connection portion of pipes of dirt or grease. Remove any solder build-up on connections by heating with soldering torch and wiping with clean rag.

CAUTION

Do not allow solder particles or other debris to enter piping or condenser.

- b. Align all piping connections, position condenser (1), and install mounting hardware for each steel leg (4).
- c. Connect (solder) the following lines to the condenser (1):
 - (1) Refrigerant outlet line connection (6).
 - (2) Seawater inlet line connection (5).
 - (3) Seawater outlet line connection (3).
 - (4) Refrigerant inlet line connection (2).
- d. Open external seawater inlet and outlet valves.
- e. Charge system with R-22 refrigerant.
- f. Operational check:
 - (1) Turn electrical power ON.
 - (2) Start and run air conditioner to check operation.
 - (3) Remove "Out-of-Service" tag from circuit.

Section VI. PREPARATION FOR STORAGE

2-37. Extended Shutdown or Storage. If, for any reason other than seasonal requirements, the operating equipment in the environmental control subsystem (HVAC) is shut down for a period exceeding 1 year, the maintenance procedures in step a. below must be performed. Maintenance procedures and requirements for equipment startup after extended shutdown are given in step b.

a. Extended shutdown of operating equipment.

(1) Heating equipment (DH/UH/CH):

- (a) Perform all Daily, Monthly, and Annual PMCS schedules (Table 2-1).
- (b) Turn electrical power OFF and tag "Out of Service."

(2) Ventilation Fans (SF/EF):

- (a) Perform all Daily, Monthly, Semi-Annual and Annual PMCS schedules (Table 2-1).
- (b) Turn electrical power OFF and tag "Out of Service."

(3) Air Conditioners (A/C):

- (a) Perform all Daily, Monthly, Bi-Monthly, Semi-Annual, and Annual PMCS schedules (Table 2-1).
- (b) Turn electrical power OFF and tag "Out of Service."

b. Startup of equipment after extended shutdown/storage.

(1) Heating equipment (DH/UH/CH):

- (a) Conduct pre-inspection and service (paragraph 2-9a).
- (b) Start and run heater to check operation (paragraph 2-9a).
- (c) Remove "Out of Service" tag from circuit.

(2) Ventilation Fans (SF/EF):

- (a) Conduct pre-inspection and service (paragraph 2-9b).
- (b) Start and run fan to check operation (paragraph 2-9b).
- (c) Remove "Out of Service" tag from circuit.

CAUTION

If the Accommodations Units (A/C #2) main power breaker, or disconnect switch, has been turned OFF for over 4 hours, the unit's HEAT/OFF/Cool manual switch on thermostat must remain OFF for a period of 5 hours after turning main power breaker, or disconnect, ON. This energizes the compressor crankcase heater and allows the oil time to re-heat.

(3) Air Conditioners (A/C):

- (a) Conduct pre-inspection and service (paragraph 2-9c).
- (b) Start and run air conditioner to check operation (paragraph 2-9c).
- (c) Remove "Out of Service" tag from circuit.

CHAPTER 3

INTERMEDIATE DIRECT SUPPORT MAINTENANCE INSTRUCTIONS

	Page
Section I. Repair Parts, Special Tools; Test, Measurement, and Diagnostic Equipment (TMDE); and Support Equipment.....	3-1
Section II. Service Upon Receipt.....	3-1
Section III. Intermediate Direct Support Preventive Maintenance Checks and Services (PMCS).....	3-2
Section IV. Intermediate Direct Support Troubleshooting.....	3-2
Section V. Intermediate Direct Support Maintenance Procedures.....	3-11
Section VI. Preparation for Storage or Shipment.....	3-68

SECTION I. REPAIR PARTS, SPECIAL TOOLS; TEST, MEASUREMENT, AND DIAGNOSTIC EQUIPMENT (TMDE); AND SUPPORT EQUIPMENT

3-1. **Common Tools and Equipment** . For authorized common tools and equipment, refer to the Modified Table of Organization and Equipment (MTOE) applicable to your organization.

3-2. **Special Tools, TMDE, and Support Equipment** . Special tools; test, measurement, and diagnostic equipment; and support equipment requirements-are listed and illustrated in the Repair Parts and Special Tools List (RPSTL), TM 55-1905-223-24P1. These items are also listed in the Maintenance Allocation Chart (MAC), Appendix B of this manual.

3-3. **Repair Parts**. Repair parts are listed and illustrated in the Repair Parts and Special Tools List (RPSTL), TM 55-1905-223-24P1.

SECTION II. SERVICE UPON RECEIPT

3-4. Checking Unpacked Equipment.

- a. Inspect the equipment for damage incurred during shipment. If the equipment has been damaged, report the damage in accordance with the instructions of DA Pam 738-750.
- b. Check the equipment against the packing slip to see if the shipment is complete. Report all discrepancies in accordance with the instructions of DA Pam 738-750.
- c. Check to see whether the equipment has been modified.

- d. Remove protective caps, plugs, inserts, wrappings, and tape when inspection/inventory is completed. Inspect piping openings for damage. Wipe off dirt, grease, or protective films at time of installation.
- e. Remove chocks from resilient mounted components.

3-5. **Initial Setup Procedure.** Includes operational checks and inspections that are not performed for a routine startup. Direct support maintenance personnel will perform initial setup in accordance with the operator's manual, TM 55-1905-223-10.

3-6. **Normal Startup.** Refer to the operator's manual, TM 55-1905-223-10.

3-7. **Shutdown Procedure (Usual or Unusual).** Refer to the operator's manual, TM 55-1905-223-10.

**Section III. INTERMEDIATE DIRECT SUPPORT PREVENTIVE
MAINTENANCE CHECKS AND SERVICES (PMCS)**

3-8. **PMCS.** There is no PMCS at the general support level. See Chapter 2, Section III.

SECTION IV. INTERMEDIATE DIRECT SUPPORT TROUBLESHOOTING

3-9. **Troubleshooting.** Both a symptom index and a troubleshooting table are provided. The symptom index will help you locate the information you need for troubleshooting.

SYMPTOM INDEX

	Troubleshooting Procedure (Table 3-1)
HEATING	
No heat - fan/blower running	Item 1
Not enough heat	Item 2
VENTILATION (FANS)	
Excessive noise or vibration	Item 3
Fan does not operate	Item 4
AIR CONDITIONING	
Compressor crankcase cold (sweating or frosting)	Item 9
Compressor short cycles on high pressure cut-out	Item 11
Compressor will not start	Item 10
High operating head (discharge) pressure	Item 5
High suction pressure	Item 7
Low operating head (discharge) pressure	Item 6

SYMPTOM INDEX - CONT

	Troubleshooting Procedure (Table 3-1)
Low suction pressure	Item 8
No cooling - blower does not run	Item 12
No cooling - blower running	Item 13
Partial or insufficient cooling - blower running	Item 14
Water leaking from the unit	Item 15

Table 3-1 lists the common fault conditions that may be found during operation or maintenance of the equipment. Look for causes and do corrective actions in the order listed. This manual cannot list every symptom that may show up, and it cannot list all of the possible causes and corrective actions. If a symptom is not listed, or if it keeps up after you have performed the corrective actions, notify your supervisor.

Table 3-1. Troubleshooting

Malfunction

Test or Inspection

Corrective Action

HEATING

1. No heat - fan/blower running.
 - STEP 1. Check for open manual or automatic limit switch. Reset manual limit switch. If trips again, check for defective manual and automatic limit switch. Replace as required (paragraphs 3-12 and 3-13).
 - STEP 2. Check for defective air flow switch on duct heaters. Check for air flow to heater. Replace defective air flow switch as required (paragraphs 3-11 and 3-13).

2. Not enough heat.
 - STEP 1. Check for defective air flow switch. Replace as required (paragraphs 3-11 and 3-13).
 - STEP 2. Check for element failure
 - a. Clean and secure connections.
 - b. Replace element (paragraph 3-16).

Table 3-1. Troubleshooting

Malfunction	Test or Inspection	Corrective Action
--------------------	---------------------------	--------------------------

VENTILATION FANS (SUPPLY AND EXHAUST)

WARNING

Make sure a fan is not in a stalled condition before attempting maintenance. Severe injury could result if fan operates while being worked on.

3. Excessive noise or vibration.

STEP 1 Check for impeller out of balance, worn, or corroded. Replace impeller or fan as required (paragraph 3-17, 3-19, 3-21, 3-22, or 3-23 or 3-24).

STEP 2. Check for worn or defective bearings. Replace bearings as required (paragraphs 3-17 through 3-24).

4. Fan does not operate.

STEP 1 Check for defective fan motor. Replace fan motor (paragraph 3-18, 3-20, 3-21, 3-22, 3-23, or 3-24).

AIR CONDITIONING

5. Higher than normal operating head (discharge) pressure.

STEP 1 Check to see if refrigerant is overcharged.

a. Remove excess refrigerant:

NOTE

Self-contained units are not equipped with discharge service valve for attaching high pressure hoseline of portable gauge to obtain discharge pressure.

A/C-1 and 3 are self-contained units.

(1) Shut down compressor and remove front cabinet panel for access to compressor.

Table 3-1. Troubleshooting - CONT

Malfunction	Test or Inspection	Corrective Action
-------------	--------------------	-------------------

VENTILATION FANS (SUPPLY AND EXHAUST) - CONT

- (2) Connect the combination gauge hose line of a portable gauge manifold to the charging valve on compressor. Make sure gauge port handwheels on manifold are closed fully clockwise before attaching hose line.
- (3) Connect the common (center) hose line of the manifold to an empty approved type, steel refrigerant container (Item 7, Appendix C). Open valve on container.
- (4) Crack open the handwheel on the combination gauge port on the manifold momentarily for 2 to 3 seconds. Close handwheel. This will allow a small amount of refrigerant to be released into the empty container. Repeat above procedure until excess refrigerant is removed.

STEP 2. Check to see if seawater pump is running and water is flowing through condenser. Replace water regulating valve as required (paragraph 3-25).

6. Lower than normal operating head (discharge) pressure.

STEP 1 Check for excessive water flow through condenser.

STEP 2 Check for leaky compressor discharge or suction valve plate.

NOTE

A lower than normal discharge pressure combined with a higher than normal suction pressure indicates a leaky valve plate.

Replace hermetic type (sealed) compressor; A/C-1 and 3 (paragraph 3-25).

- STEP 3. Check to see if wrong refrigerant is in the system.
- a. Make certain R-22 only was added to the system. If not, remove refrigerant, evacuate, and recharge with-R-22 (paragraph 3-10).
 - b. On self-contained air conditioners (A/C-1 and 3), remove complete charge, evacuate, and add new R-22 refrigerant charge (paragraph 3-10).

7. Higher than normal suction pressure.

STEP 1 Check for leaky compressor suction valve plate.

Table 3-1. Troubleshooting - CONT

Malfunction	Test or Inspection	Corrective Action
-------------	--------------------	-------------------

AIR CONDITIONING - CONT

NOTE

A higher than normal suction pressure combined with a discharge pressure lower than normal indicates a leaky valve plate.

Replace compressor (paragraph 3-25).

8. Lower than normal suction pressure.

STEP 1 Check to see if there is sufficient refrigerant.

a. Add R-22 refrigerant as follows:

A/C-1 and 3 are self-contained units.

WARNING

PRESSURIZED GAS HAZARD. Handle R-22 refrigerant containers with care to avoid personal injury. Keep containers away from external heat sources. DO NOT DROP containers. When in use, place containers where they will not be knocked over.

- (1) Shut down unit and remove front lower cabinet panel for access to charging valve and sight glass on the compressor. Remove protective cap on charging valve.
- (2) Use a portable gauge manifold for adding refrigerant. Make sure that both handwheels on the gauge manifold are fully closed clockwise before connecting hoses.

WARNING

Wear protective gloves when connecting and disconnecting hose to charging valve to protect against momentary release of refrigerant.

- (3) Connect the combination (suction) hose of the gauge to the charging valve on the compressor. Connect the common (middle) hose of the gauge to a container of new R-22 refrigerant. Make sure container is in an upright position.

Table 3-1. Troubleshooting - CONT

Malfunction	Test or Inspection	Corrective Action
-------------	--------------------	-------------------

AIR CONDITIONING - CONT

NOTE

Purge lines of air before connecting gauge set to service valves.

- (4) Start and run the compressor for 5 minutes before continuing.

NOTE

When system is low on refrigerant, the sight glass next to the charging valve on the compressor will show a stream of bubbles or a foamy appearance.

- (5) Open the valve on the container of refrigerant counterclockwise. While watching the sight glass, slowly crack open the gauge port hand wheel on the combination (suction) gauge momentarily for 1 or 2 seconds, adding a small amount of refrigerant. Close handwheel and observe sight glass condition.
- (6) If bubbles are still present, repeat cracking and closing combination with gauge handwheel until the sight glass shows a clear condition. Do not continue adding refrigerant once the sight glass has cleared.
- (7) When sight glass has cleared, close valve on refrigerant container.
- (8) Shut down compressor.
- (9) Disconnect manifold hoses from refrigerant container and charging valve on compressor. Install protective cap on charging valve.

9. Compressor crankcase cold (sweating or frosting).

STEP 1. Check to see if refrigerant is overcharged. Remove excess refrigerant (Malfunction 5).

10. Compressor will not start.

STEP 1. Check for low refrigerant charge.

a. Repair any leaks, evacuate, and recharge system with R-22 as follows:

- (1) Leak test refrigerant line and components:

Table 3-1. Troubleshooting - CONT

Malfunction	Test or Inspection	Corrective Action
-------------	--------------------	-------------------

AIR CONDITIONING - CONT

WARNING

Turn electrical power OFF.

- (2) With the unit shutdown, use the refrigerant gas leak detector in the refrigeration tool kit and check all lines and components in the system for leaks.

NOTE

Leaks commonly occur in defective joints, fittings, gaskets, and in breaks caused by vibration.

A portable gauge manifold must be hooked up on self- contained air conditioners (A/C-1 and 3) to determine pressure.

- (3) If refrigerant has been lost due to a leak and pressure is below 175 psig, add enough R-22 refrigerant to system so that pressure is increased to 175 psig before checking for leaks (Malfunction 8).
- (4) Locate leak and correct as required.

NOTE

Self-contained air conditioners (A/C-1 and 3) cannot be pumped down. The refrigerant charge must be completely removed before opening the system for maintenance purge, and recharged with new refrigerant before returning to normal operation (paragraph 3-10).

- (5) Remove the refrigerant charge as required by corrective action (Malfunction 5).
- (6) After corrective action is complete, add R-22 refrigerant (Malfunction 8) or evacuate and recharge system (paragraph 3-10) as appropriate.

STEP 2. Check for defective transformer (A/C-1 and 3). Replace transformer (paragraph 3-25).

Table 3-1. Troubleshooting - CONT

Malfunction	Test or Inspection	Corrective Action
AIR CONDITIONING - CONT		
	STEP 3.	Check for open contact on internal overload protector in compressor (A/C-1 and 3). Allow time for compressor to cool and automatically reset. If it does not reset when cooled down, do the following. Check for "open" or "short" in compressor (paragraph 2-15). Replace as required (paragraph 3-25).
	STEP 4.	Check for defective compressor or compressor motor.
	a.	Test compressor or compressor motor for a "short" or "open" condition (paragraph 2-17).
	b.	Replace defective compressor (paragraph 3-25).
11.	Compressor short cycles on high pressure cut-out.	
	STEP 1.	Check to see if high (discharge) pressure control (solenoid) is defective. Check for defective control. Replace as required (paragraph 3-25).
12.	No cooling - blower does not run.	
	STEP 1.	Check to see if fan relay or capacitor is defective (A/C-1 and 3). Replace relay or capacitor as required (paragraph 3-25).
	STEP 2.	Check for defective fan motor. Replace fan motor (paragraph 3-25).
13.	No cooling - blower running.	
	STEP 1.	Check for defective run capacitor (self-contained units; A/C-1 and 3). Replace as required (paragraph 3-25).
14.	Partial or insufficient cooling - blower running.	
	STEP 1.	Check for low refrigerant charge. Find and repair leak (Malfunction 10). Evacuate and recharge system with R-22 (paragraph 3-10).
	STEP 2.	Check for air in system. Remove refrigerant, evacuate, and recharge with R-22 (paragraph 3-10).

Table 3-1. Troubleshooting - CONT

Malfunction	Test or Inspection	Corrective Action
-------------	--------------------	-------------------

AIR CONDITIONING - CONT

15. Water leaking from unit.

STEP 1. Check to see if condensate pump motor is running on self-contained units (A/C-1 and 3).

WARNING

Check motor for loose electrical connections. Secure as required. Check motor windings (paragraph 2-15). If "short" or "open" in motor windings, replace defective motor or pump assembly as required (paragraph 3-25).

STEP 2. Check for defective impeller on condensate pump on self-contained units (A/C-1 and 3). Check water in condensate drain pan. A defective pump impeller may cause the water to churn, but will not empty from pan. Replace pump if impeller is defective (paragraph 3-25).

SECTION V. INTERMEDIATE DIRECT SUPPORT MAINTENANCE PROCEDURES.

There are no separate procedures for equipment for which repair parts are not stocked

MAINTENANCE OF ENVIRONMENTAL CONTROL SUBSYSTEM

3-10. **Removing Charge, Evacuating System, and Recharging.** For A/C-1 and 3 (self-contained units), use the following procedures to remove refrigerant charge, evacuate, and recharge with R-22 refrigerant:

- a. Remove Refrigerant Charge (A/C-1 and 3).
 - (1) Shut down the unit.
 - (2) Remove front panel of unit for access charging valve on compressor.
 - (3) Connect a portable gauge manifold hookup as follows:
 - (4) Make sure both gauge port handwheels on the manifold are closed fully clockwise.

WARNING

Wear protective gloves when connecting hose to charging valve to protect against momentary escape of cold refrigerant.

- (5) Remove the protective cap on the charging valve.

NOTE

An adapter from the refrigeration tool kit must be used for connecting gauge manifold to charging valve on compressor.

- (6) Connect the combination (suction) hose from gauge manifold to the charging valve on the compressor. Connect the common (middle) hose from the manifold to the valve of an empty R-22 refrigerant container.
- (7) Leave the high pressure hose plugged.

WARNING

PRESSURIZED GAS HAZARD. Handle R-22 refrigerant containers with care to avoid personal injury. Keep containers away from external heat sources. DO NOT DROP containers. When in use, place containers where they will not be knocked over.

- (8) Slowly open the combination gauge handwheel on the manifold. Refrigerant will escape into the approved recovery/recycling system. See figure 3-1a.

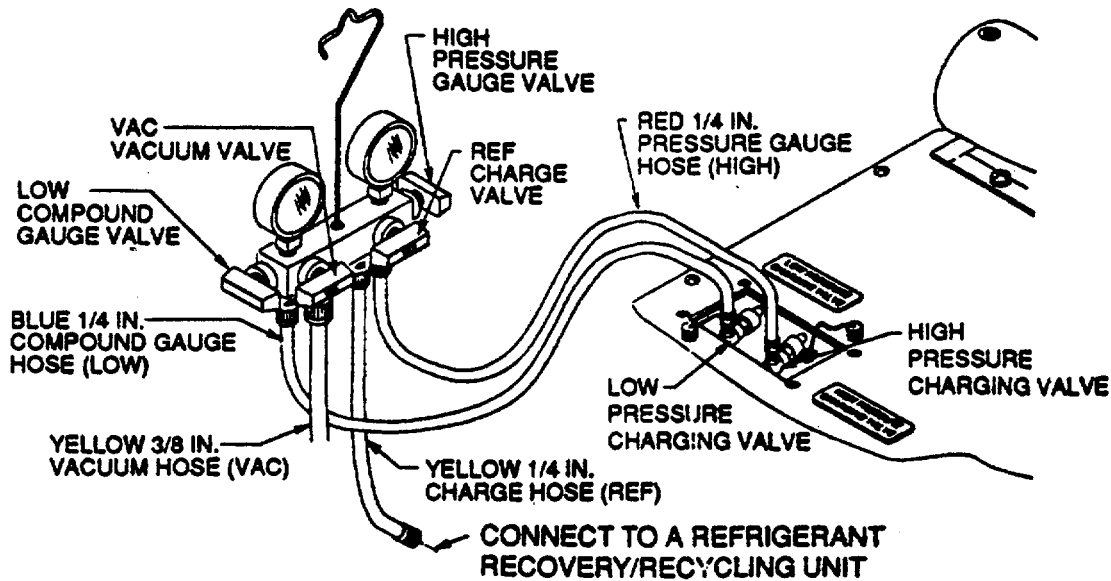

Figure 3-1a. Discharging Refrigerant

- (9) Follow instructions per your approved recovery/recycling system.

b. Evacuate System (A/C-1 and 3).

- (1) Before evacuating and charging self-contained units, a line piercing valve from the refrigeration tool kit must be installed in the discharge line from the compressor.

NOTE

The line piercing valve will remain on the discharge line and can be used in the future for evacuating system and for connecting a gauge manifold and observing discharge pressure.

- (2) Use a refrigeration vacuum pump and portable gauge manifold to evacuate the system.
- (3) Make sure both gauge port handwheels on the manifold are closed.
- (4) Connect the combination gauge vacuum hoseline from the manifold to the charging valve on the compressor. Connect the high pressure gauge hoseline from the manifold to the line piercing valve in the discharge line from the compressor. Make sure the needle valve of the piercing valve is open (screwed out three or four turns counterclockwise).
- (5) Connect the common (middle) hoseline from the manifold to the suction connection of a vacuum pump.
- (6) Make sure all hoseline connections are secure.
- (7) Start and run the vacuum pump. Slowly open both gauge port handwheels on the manifold counterclockwise.

NOTE

It may be necessary to restrict the vacuum pump suction pressure by means of the gauge port handwheels to avoid overloading the vacuum pump motor.

Evacuation of system may be a slow process.

- (8) Continue running vacuum pump until a reading of 18 inches vacuum is obtained on both gauges (or to the limit of the vacuum pump's ability).
 - (9) When evacuation is complete, close both gauge port handwheels on the manifold fully clockwise. Stop the vacuum pump.
 - (10) Leave the gauge manifold connected and wait 15 minutes. Check pressure readings.
 - (11) If the vacuum has been lost, or if you were unable to obtain a vacuum initially, there is loose hoseline connection or a leak in the system. Check hoseline connections.
 - (12) Test for a leak (Item 10, Table 3-1) and repeat the above evacuation procedure.
 - (13) Once you are able to maintain a vacuum reading on the gauges, disconnect the common hoseline from the vacuum pump and connect it to a container of refrigerant
 - (14) Loosen the common hoseline connection at the gauge manifold momentarily, crack the refrigerant container valve to purge the hose, and retighten the hose connection.
 - (15) Crack the valve on the refrigerant container. Crack the valves (handwheels) on the gauge manifold until the system pressure rises to 2 psig. Close the valve on the refrigerant container and both handwheels of the manifold.
 - (16) Disconnect the common hoseline from the refrigerant container and reconnect it to the suction connection on the vacuum pump.
 - (17) Start the vacuum pump, slowly open both handwheels on the manifold, and again evacuate the system to 18 inches vacuum (or to limit of pump's ability).
 - (18) Close both handwheels on the manifold, stop the vacuum pump, and wait 15 minutes to see that a vacuum is held.
 - (19) When a vacuum is maintained, disconnect the common hoseline from the vacuum pump.
 - (20) The system is now ready to recharge.
- c. Recharge System (A/C-1 and 3).
- (1) Determine the weight of refrigerant charge required from the data plate on the unit.
 - (2) Use the scale from the refrigeration tool kit and weigh the refrigerant container before charging. Make sure the container is holding more refrigerant (weight) than required for the charge.
 - (3) With the system evacuated and the portable gauge manifold still hooked up to the unit, connect the common hoseline of the manifold to the refrigerant container.

- (4) Crack the valve on the container momentarily and then close. Loosen the common hose line connection at the manifold to purge the hose, then resecure the connection.

WARNING

Do not use water warmer than 110°F to avoid over-expansion of refrigerant in container.

- (5) Place the refrigerant container upright in a container of warm water that is no warmer than 110°F. This will maintain container pressure and expedite charging.

WARNING

DO NOT apply heat with a torch.

- (6) Start the compressor. Slowly open the low side handwheel on the combination gauge. DO NOT open the high side handwheel. Charging must be accomplished through the charging valve on the suction line.
- (7) Observe both gauges on the manifold while charging. Also observe the sight glass located next to the charging valve on the compressor.
- (8) When operating pressures are within proper range (suction: 55 to 72 psig, discharge: 190 to 275 psig), close the low side handwheel on the manifold. Check the sight glass. If bubbles, or a stream of bubbles, are observed, crack the handwheel and add more refrigerant until sight glass clears. DO NOT continue adding after sight glass has cleared. Stop the compressor.
- (9) Again weigh the refrigerant container to determine if system has been overcharged. Deduct the weight of the container from the initial weight obtained before charging. The result is the weight actually added to the unit.
- (10) If the result is in excess of the amount required by the unit's dataplate, release a small amount of refrigerant. Close the valve on the container, make sure the handwheel on the combination gauge is closed, and disconnect the common hose line from the container. Release a small amount of refrigerant by momentarily cracking the handwheel on the combination gauge. Take care not to release too much, or refrigerant may have to be added back.
- (11) Start the compressor, allow to run for 5 minutes, and again check operating pressures and sight glass.
- (12) When charging is complete, allow to run for 5 minutes, and again check operating pressures and sight glass.
- (13) Disconnect the portable gauge manifold and install protective caps on charging valve and piercing valve.

3-10d. DISCHARGING THE REFRIGERANT SYSTEM.

This task covers:

a. Discharging

INITIAL SETUP:

Tools:

Refrigeration Unit Service Tool Kit

Goggles

Gloves

Refrigerant Recovery and Recycle Unit

Equipment Condition

Install Service Manifold

General Safety Instructions

WARNING

DANGEROUS CHEMICAL REFRIGERANT UNDER PRESSURE is used in the operation of this equipment.

DISCHARGING

WARNING

DANGEROUS CHEMICAL REFRIGERANT UNDER PRESSURE is used in the operation of this equipment.

NOTE

Use great care to avoid contact with liquid refrigerant or inhaling refrigerant gas being discharged from any container under pressure. Sudden and irreversible tissue damage can result from freezing. Wear thermal protective gloves and a face protector or safety glasses in any situation where skin or eye contact is possible.

Prevent contact of refrigerant gas with flame or hot surfaces. Heat causes the refrigerant to break down and form carbonyl chloride (phosgene), a highly toxic and corrosive gas.

3-10d. DISCHARGING THE REFRIGERANT SYSTEM. - continued

NOTE

In accordance with Environmental Protection Agency (EPA) regulations, refrigerants can not be discharged into the atmosphere. A refrigerant recovery/recycling unit must be used whenever discharging the refrigeration system.

1. Connect the yellow 1/4 inch (charge) hose to an approved refrigerant recovery/recycling unit.

CAUTION

Follow instructions for specific container or refrigerant recovery unit being used to avoid compressor oil loss. Loss of oil could result in compressor damage.

2. Open pressure gauge and compound gauge valves.

NOTE

Operation of the recovery/recycling unit must be by authorized personnel only.

3. Operate the recovery/recycling unit in accordance with the manufacturer's instructions.

3-11. Repair Heater, Duct Type, Stationary (Duct #1)

This task covers:

a. Removal

b. Repair

c. Replacement.

INITIAL SETUP:**Tools:**

Tool kit, general mechanic's,
5180-00-699-5273
Tool kit, electrician's,
5180-00-391-1087

Equipment Condition

Circuit breaker switched OFF, power
panel locked "Out of Service -
Do Not Operate."

See TM 55-1905-223-10 for HVAC
systems operation and equipment
location.

Materials / Parts

Tags, Item 1 Appendix C
Control contactor P/N C133-011
Control transformer P/N C316-022
Control contactor P/N C123-021
Thermostatic switch P/N C241-005
Thermostatic switch P/N C231-042
Thermostatic switch P/N C232-038

REMOVAL**WARNING**

Make sure electrical power is OFF to avoid personal injury.

- a. Open terminal box doors (5, 7, FIGURE 3-1).
- b. Tag and disconnect electrical power supply wiring to heater (2).
- c. Tag and disconnect thermostat wiring to the heater (2).
- d. Withdraw power supply and thermostat wires from the terminal box.
- e. Remove the mounting screws (1) holding heater to ducting.
- f. Slide the heater (2) from the ducting.

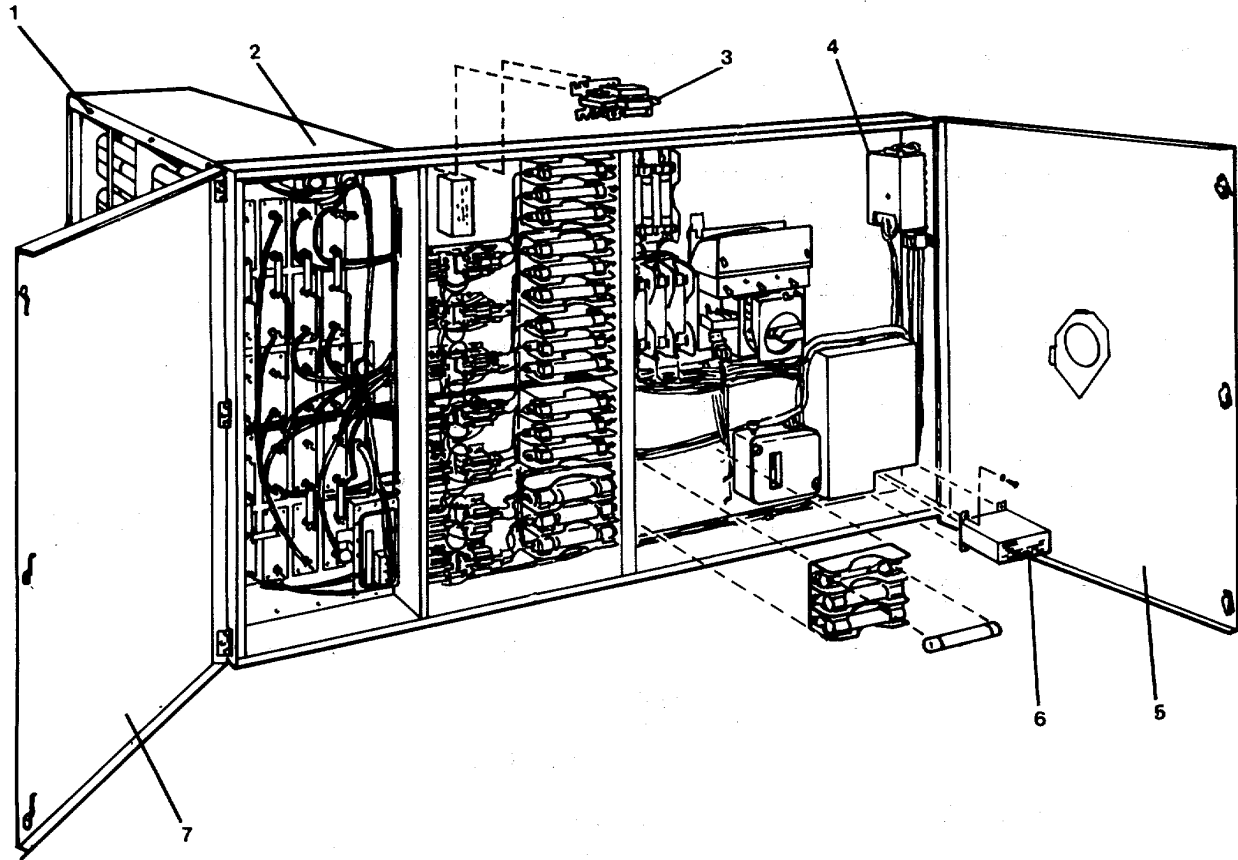

Figure 3-1. Duct Heater (DH #1).

REPAIR**WARNING**

Turn electrical power to OFF to avoid personal injury.

- a. Turn electrical power to heater OFF and open terminal box doors (5, 7).
- b. Replace control contactors (3) and/or (4):
 - (1) Tag and disconnect electrical wiring from appropriate contactor(s).
 - (2) Remove contactor (3) and/or (4) from terminal box.
 - (3) Install a new contactor (3) and/or (4).
 - (4) Connect electrical wiring to contactor terminals.
- c. Replace control transformer (6).
 - (1) Tag and disconnect electrical wiring from transformer.
 - (2) Remove transformer from terminal box.
 - (3) Install new control transformer (6).
 - (4) Connect electrical wiring to transformer terminals.
- d. Replace thermostatic switches (3, 4, 5, FIGURE 3-2):
 - (1) Remove duct heater (removal step in this procedure).
 - (2) Replace appropriate thermostatic switch in the heater (2) element box (1):
 - (a) Tag and disconnect electrical wiring from appropriate switch.
 - (b) Remove appropriate switch (3, 4, or 5) from element box (1).
 - (c) Install new thermostatic switch (3, 4, or 5).
 - (d) Connect electrical wires to switch terminals.
- e. Close terminal box doors (5, 7, FIGURE 3-1).

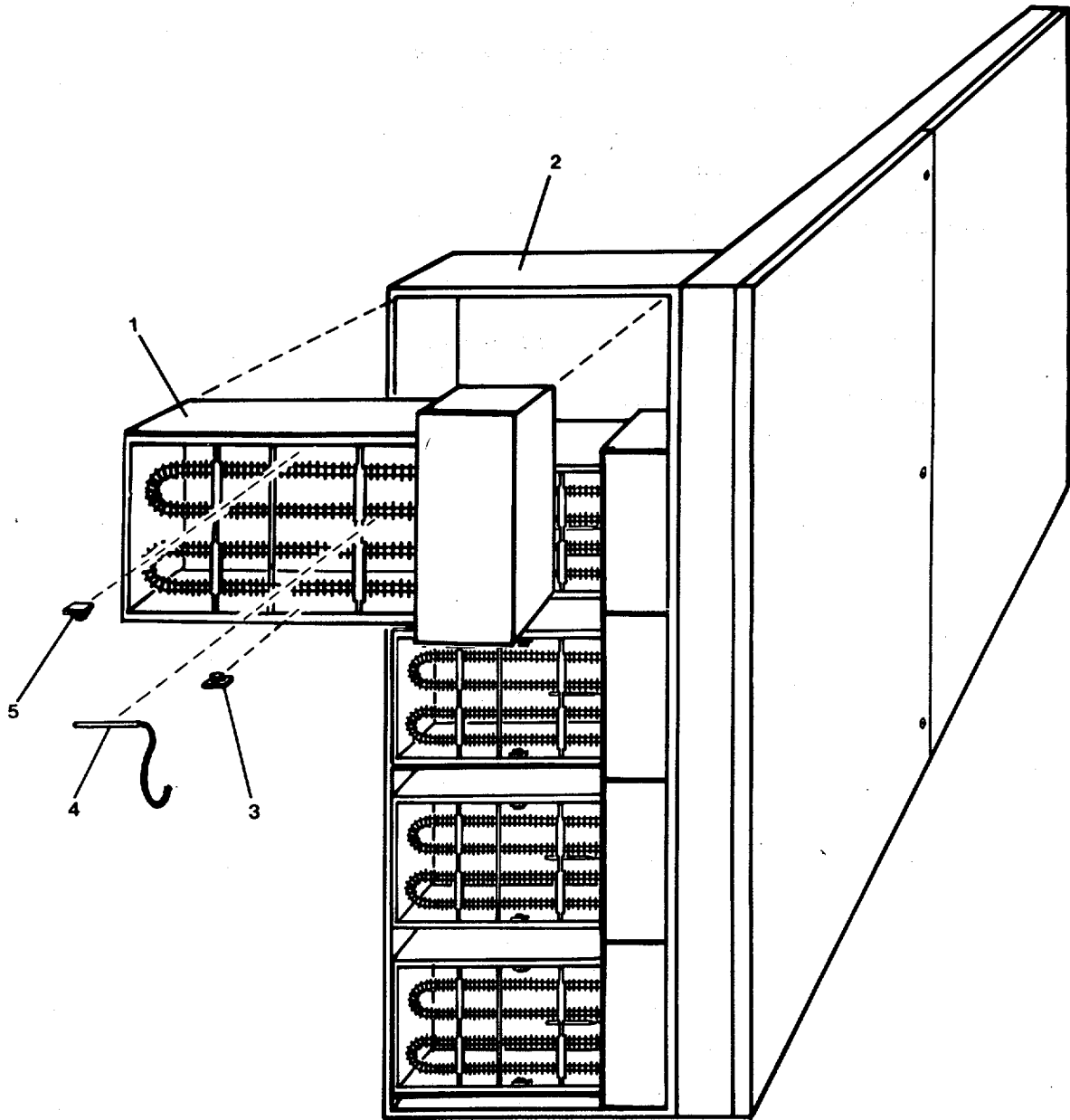

FIGURE 3-2. *Thermostatic Switches (DH #1).*

REPLACEMENT

- a. Install heater (2, FIGURE 3-1) in ducting with mounting screws (1).
- b. Run power supply and thermostat wiring into terminal box on the heater (2).
- c. Connect power supply wires to proper terminals.
- d. Connect thermostat wires to proper terminals.
- e. Close terminal box doors (5, 7).
- f. Operational Check:
 - (1) Turn electrical power ON.
 - (2) Start and run heater to check for proper operation.
 - (3) Remove "Out of Service" tag from circuit.

3-12. Repair Heater, Duct Type, Stationary (Duct #2, #3, #17). (FIGURE 3-3)

This task covers:

a. **Repair**

INITIAL SETUP:

Tools

Tool kit, general mechanic's,
5180-00-699-5273
Tool kit, electrician's,
5180-00-391-1087

Materials/Parts

Tags, Item 1, Appendix C
Control contactor 52332002
(Ducts 2, 3, and 17)
Power transformer P/N 41017003
(Ducts 2, 3, and 17)
Manual limit capillary reset
P/N 41984011 (Ducts 2, 3, and 17)
Automatic limit capillary reset
P/N 50025003 (Ducts 2, 3, and 17)
Airflow switch P/N 51085002
(Ducts 2, 3, and 17)
Air probe P/N 41653001
(Ducts 2, 3, and 17)

Equipment Condition

Circuit breaker switched OFF, power
panel locked and tagged "Out of
Service - Do Not Operate."

See TM 55-1905-223-10 for HVAC systems
Operation and equipment location.

REPAIR

WARNING

Make sure electrical power is OFF to avoid personal injury.

- a. Turn electrical power to heater OFF and open terminal box door (8).
- b. Replace control contactor (7):
 - (1) Tag and disconnect electrical wiring from contactor.
 - (2) Remove associated hardware and contactor (7) from terminal box (3).

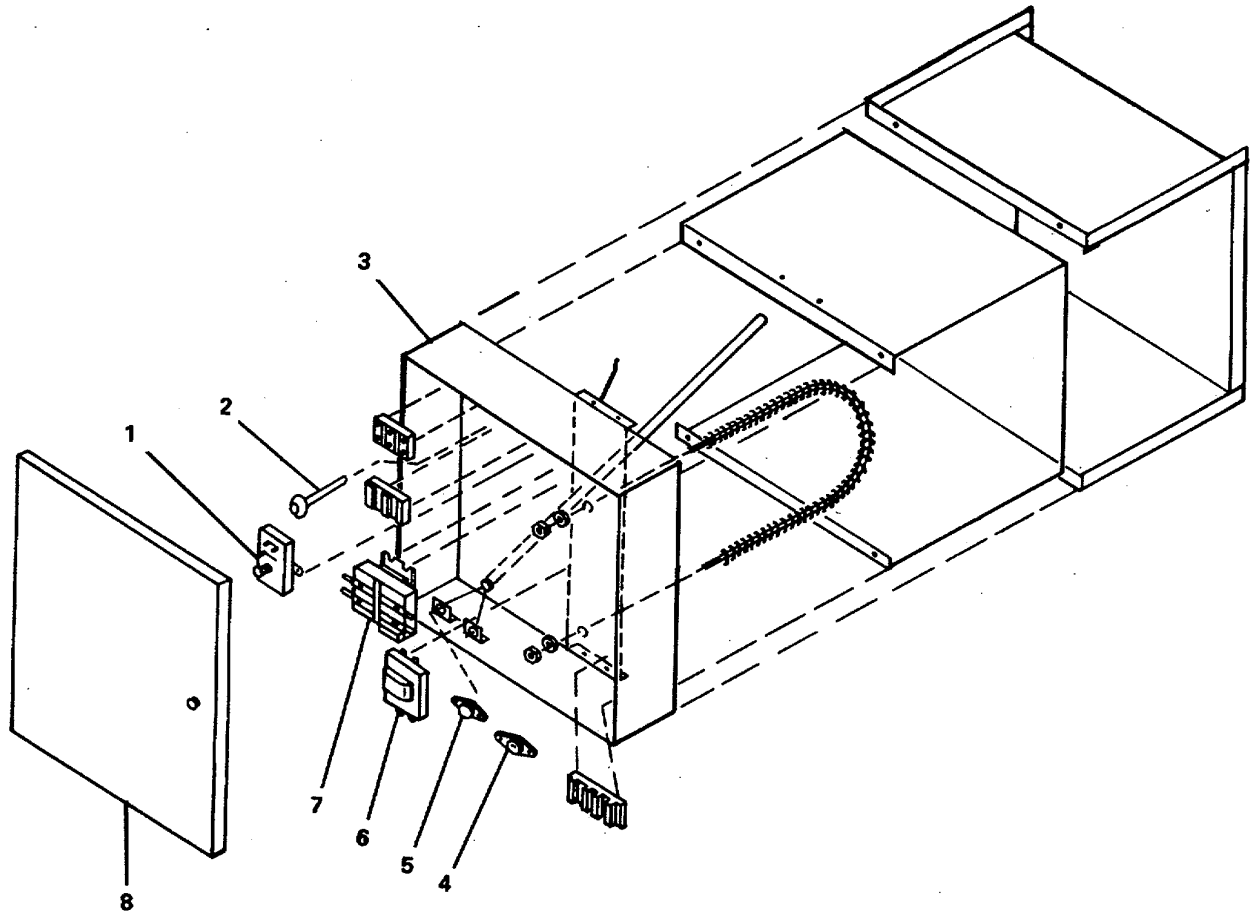

Figure 3-3. Duct Heater (DH #2, #3, and #17).

- (3) Install a new control contactor (7).
 - (4) Connect electrical wiring to control contactor terminals.
- c. Replace power transformer (6):
- (1) Tag and disconnect electrical wiring at power transformer (6).
 - (2) Remove power transformer (6) from terminal box (3).
 - (3) Install new power transformer (6).
 - (4) Connect electrical wiring to power transformer terminals (6).
- d. Replace manual limit capillary reset (4) and/or automatic limit capillary reset (5):
- (1) Tag and disconnect electrical wiring from appropriate reset (4) or (5).
 - (2) Remove reset (4) or (5) from terminal box (3).
 - (3) Install new reset (4) or (5).
 - (4) Connect electrical wiring to manual limit capillary reset (4) and/or automatic limit capillary reset (5).
- e. Replace airflow switch (1) and air probe (2):
- (1) Tag and disconnect electrical wiring to switch (1).
 - (2) Disconnect air probe (2) from airflow switch (1).
 - (3) Remove airflow switch and air probe from heater (3).
 - (4) Install new air probe (2) and airflow switch (1).
 - (5) Connect air probe (2) to airflow switch (1).
 - (6) Connect electrical wiring to terminals on airflow switch (1).
- f. Close terminal box door (8).
- g. Operational check:
- (1) Turn electrical power ON.
 - (2) Start and run heater to check for proper operation.
 - (3) Remove "Out of Service" tag from circuit.

3-13. Repair Heater, Duct Type, Stationary (Duct #4, #5, #6, #7, #8, #9, #10, #11, #12, #12A, #13, #14, #15, #16). (FIGURE 3-4)

This task covers:

a. Repair

INITIAL SETUP:

Tools

Tool kit, general mechanic's,
5180-00-699-5273

Tool kit, electrician's,
5180-00-391-1087

Materials/Parts

Tags, Item 1, Appendix C

Manual limit capillary reset
P/N 41984011

Automatic limit capillary reset
P/N 50025003

Airflow switch P/N 51085002

Air probe P/N 41653001

Control contactor P/N 52332005
(Duct 8, 11)

Equipment Condition

Circuit breaker switched OFF, power
panel locked and tagged "Out of
Service - Do Not Operate."

See TM 55-1905-223-10 for HVAC systems
operation and equipment location.

REPAIR

WARNING

Make sure electrical power is OFF to avoid personal injury.

- a. Turn electrical power to heater (3) OFF and open terminal box door (7).
- b. Replace manual capillary reset (4) and/or automatic capillary reset (5):
 - (1) Tag and disconnect electrical wiring from appropriate reset.
 - (2) Remove mounting screws and remove reset.
 - (3) Install new reset.
 - 4) Connect electrical wiring to proper terminal on reset.

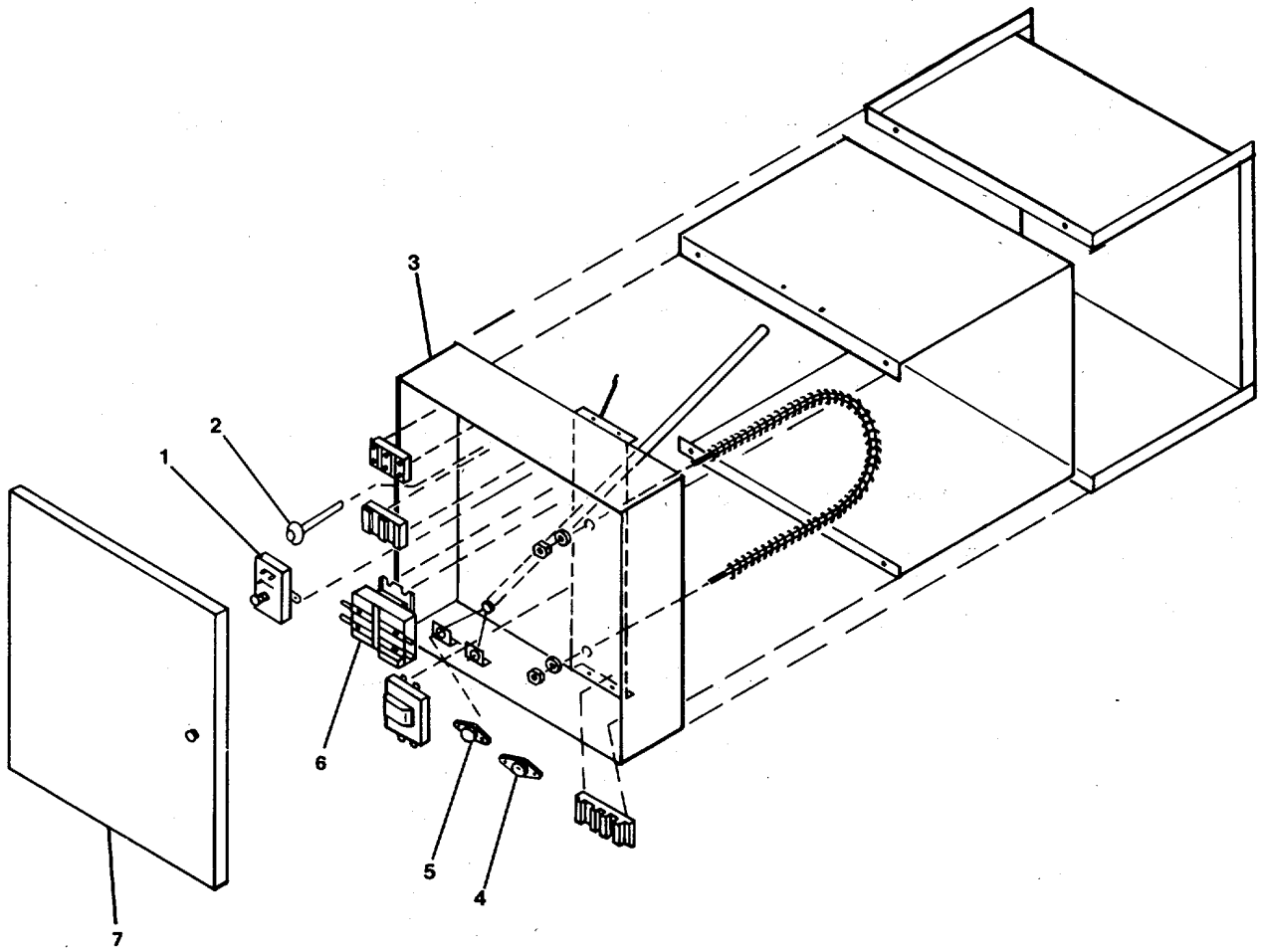

FIGURE 3-4 . Duct Heater (DH #4 thru #16).

- c. Replace airflow switch (1) and air probe (2):
 - (1) Tag and disconnect electrical wiring to switch (1).
 - (2) Disconnect air probe (2) from switch (1).
 - (3) Remove mounting screws.
 - (4) Remove switch and air probe from heater.
 - (5) Install new air probe (2) and airflow switch (1).
 - (6) Connect air probe to airflow switch.
 - (7) Connect electrical wiring to proper terminal on airflow switch.
- d. Replace control contactor (in Unit 8 and Unit 11 only).
 - (1) Tag and disconnect electrical wiring at control contactor (6) terminals.
 - (2) Remove the control contactor (6).
 - (3) Install a new control contactor (6).
 - (4) Connect electrical wiring to control contactor (6) terminals.
- e. Close terminal box door (7) to heater (3).
- f. Operational check:
 - (1) Turn electrical power ON.
 - (2) Start and run heater to check for proper operation.
 - (3) Remove "Out of Service" tag from circuit.

3-14. Repair Heater, Space, Electric (Units #1, #2, #4, #9, #10, and #11). (FIGURE 3-5)

This task covers:

a. Repair

INITIAL SETUP:Tools

Tool kit, general mechanic's,
5180-00-699-5273
Tool kit, electrician's,
5180-00-391-1087

Equipment Condition

Circuit breaker switched OFF, power
panel locked and tagged "Out of
Service - Do Not Operate."

See TM 55-1905-223-10 for HVAC systems
operation and equipment location.

Materials/Parts

Tags, Item 1, Appendix C
Knob P/N 169-049278-001
Thermostat P/N 300-049197-003
Magnetic contactor
P/N 072-049587-015 (Units 1 and 2)
Magnetic contactor
P/N 072-052560-003 (Units 4, 9, 10, and 11)
Thermostatic switch
P/N 300-049200-001
Alternating current motor
P/N 193-130381-007
(Units 1, 2, 4 and 10)
P/N 193-130381-002
(Units 9 and 11)

REPAIR**WARNING**

Make sure electrical power is OFF to prevent personal injury.

- a. Turn electrical power to heater (1) OFF.
- b. Replace thermostat and knob:
 - (1) Remove knob (3) from front side of case (15).

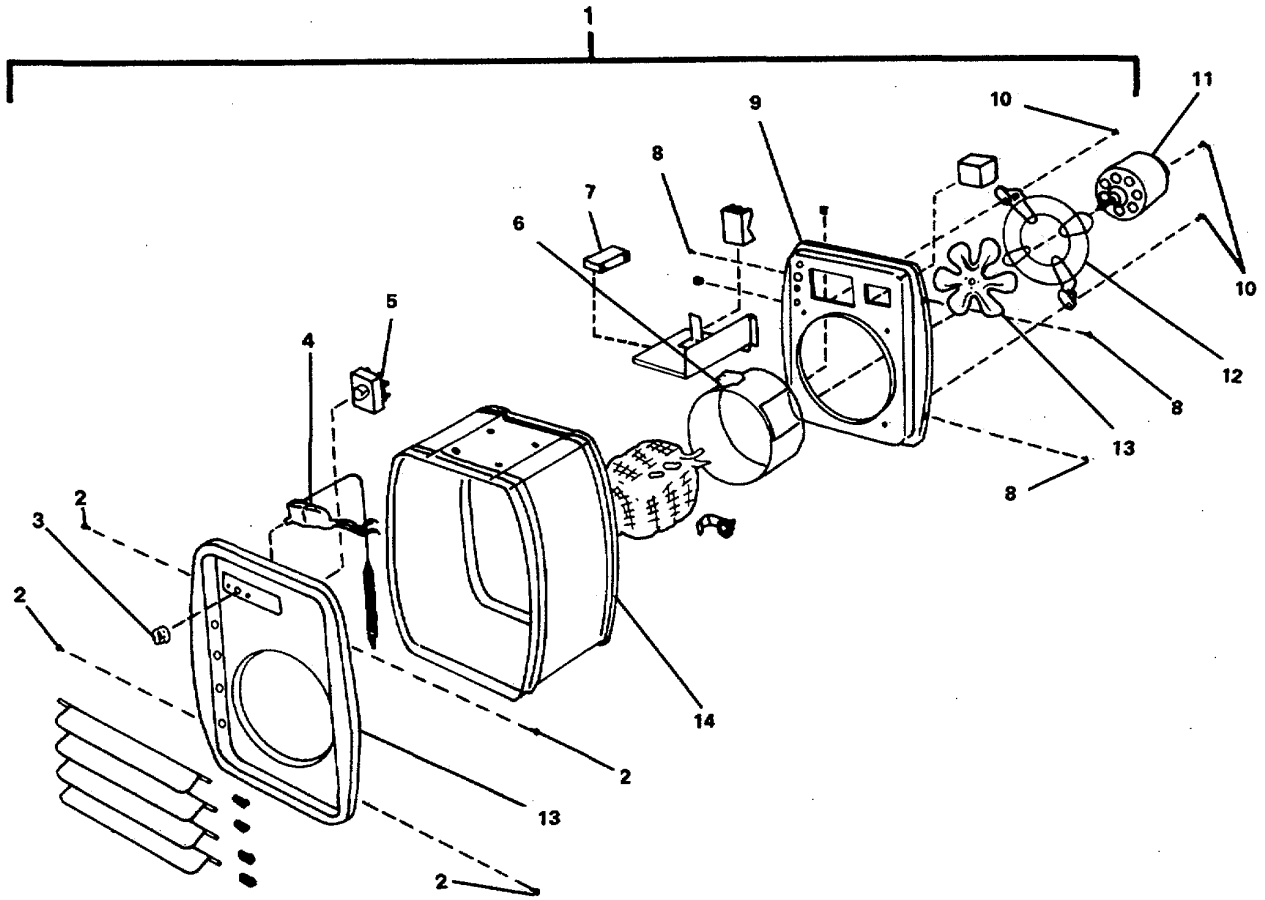

FIGURE 3-5. Unit Space Heater (UH #1, #2, #4, #9, #10, and #11).

- (2) Remove machine screws (2) to separate the front case (15) from heater case (14). Slide the front case out and away from the unit just far enough to access the thermostat (4) wiring.
- (3) Tag and disconnect the electrical wiring to the thermostat (5).
- (4) Remove the thermostat (5) from the back side of the case (14).
- (5) Install new thermostat (5).
- (6) Connect electrical wiring to proper terminals on thermostat (5).
- (7) Install case front (15) to heater case (14) with screws (2).
- (8) Install thermostat knob on front side of case (15).

c. Replace thermostatic switch and/or magnetic contactor.

- (1) Remove screws (8) to separate case back (9) from heater case (14). Gently slide case back (9) out to access thermostatic switch (6) and contactor (7).
- (2) Tag and disconnect wiring to thermostatic switch and/or magnetic contactor.
- (3) Remove defective switch or contactor.
- (4) Install new thermostatic switch (6) and/or magnetic contactor (7) as appropriate.
- (5) Connect electrical wiring to proper terminals.
- (6) Install case back (9) to heater case (14) with screws (8).

d. Replace alternating current motor:

- (1) Tag and disconnect electrical wiring from motor (11).
- (2) Remove screws (10) from guard (12) and slide the guard (12), fan (13), and motor (11) from the back case (8).
- (3) Remove fan (13) from shaft of motor (11).
- (4) Remove guard (12) from motor (11).
- (5) Install new motor (11) to guard (12).
- (6) Install fan (13) on motor (11) shaft.
- (7) Install the fan (13), guard (12), and motor (11) assembly to the case back (9) with screws (10).
- (8) Connect electrical wiring to proper terminals on motor (11).

- e. Operational check:
- (1) Turn electrical power ON to heater (1).
 - (2) Start and run heater to check operation.
 - (3) Remove "Out of Service" tag from circuit.

3-15. Repair Heater, Space, Electric (Units #3, #5, #6, and #7). (FIGURE 3-6)

This task covers:

a. Repair.

INITIAL SETUP:

Tools

Tool kit, general mechanic's,
5180-00-699-5273
Tool kit, electrician's,
5180-00-391-1087

Equipment Condition

Circuit breaker switched OFF, power
panel locked and tagged "Out of
Service - Do Not Operate."

See TM 55-1905-223-10 for HVAC systems
operation and equipment location.

Materials/Part

Tags, Item 1, Appendix C
Ventilating fan P/N M130-011
(Units 3 and 5)
Ventilating fan P/N M130-011
(Units 6 and 7)

REPAIR

Repair consists of replacing the ventilating fan.

WARNING

Make sure electrical power is OFF to avoid personal injury.

- a. Turn electrical power to heater OFF.
- b. Tag and disconnect electrical power supply wiring to heater (1).
- c. Replace ventilating fan as follows:
 - (1) Remove screws (4) to separate the control box (6) from the heater cover (2). Lower the terminal box (6) just enough to access the element wiring. Tag and disconnect the element wiring and remove the terminal box (6).
 - (2) Tag and disconnect electrical wiring to ventilating fan motor inside terminal box (6).
 - (3) Remove the ventilating fan (7) with impeller (8) attached. Remove the impeller from the motor.
 - (4) Install impeller onto motor shaft.

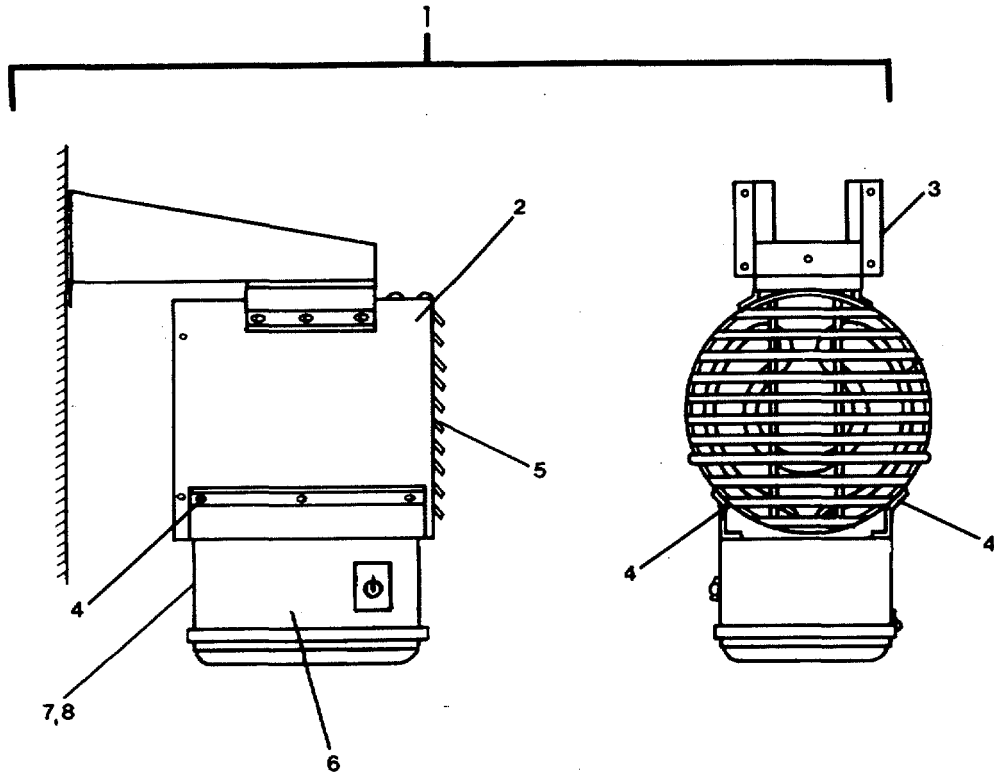

FIGURE 3-6. Unit Heater (UH #3, #5, #6, and #7).

- (5) Install ventilating fan assembly (7, 8) in the terminal box (6).
 - (6) Connect electrical wiring to proper terminals on ventilating fan and to heating elements.
 - (7) Install terminal box (6) to heater cover (2) with screws (4).
- d. Connect power supply wiring to proper terminals on heater.
- e. Operational check:
- (1) Turn electrical power to ON.
 - (2) Start and run heater to check operation.
 - (3) Remove "Out of Service" tag from circuit.

3-16. Repair Heater, Space, Electric (Convection Heaters #1, #2, #3, and #4). (FIGURE 3-7)

This task covers:**a. Repair****INITIAL SETUP:**Tools

Tool kit, general mechanic's,
5180-00-699-5273
Tool kit, electrician's,
5180-00-391-1087

Equipment Conditions

Circuit breaker switched OFF, power
panel locked and tagged "Out of
Service - Do Not Operate."

See TM 55-1905-223-10 for HVAC systems
operation and equipment location.

Materials/Parts

Tags, Item 1, Appendix C
Toggle switch P/N DK284-73
Knob P/N DFM-13
Thermostatic switch P/N G1-5280
Terminal block P/N 622-2BB
Manual thermostat P/N VDH-212153M
Heating element (Heater 1),
P/N DFM-7-11.0-1
Heating element (Heaters 2, 3, and 4)
P/N DFM-7-10.5-1

REPAIR**WARNING**

Make sure electrical power is OFF to avoid personal injury.

- a. Turn electrical power OFF to heater (1).
- b. Replace toggle switch (5) and/or manual thermostat (10).
 - (1) Remove screws (3) and lockwashers (4) and slide panel (9) out of cover (16) to reveal back side of toggle switch (5) and manual thermostat (10).
 - (2) Tag and disconnect wiring to defective toggle switch or thermostat.
 - (3) Remove toggle switch or manual thermostat from panel (9).
 - (4) Install new toggle switch (5) or thermostat (10).
 - (5) Position panel (9) on heater cover (16) and install lockwashers (4) and screws (3).

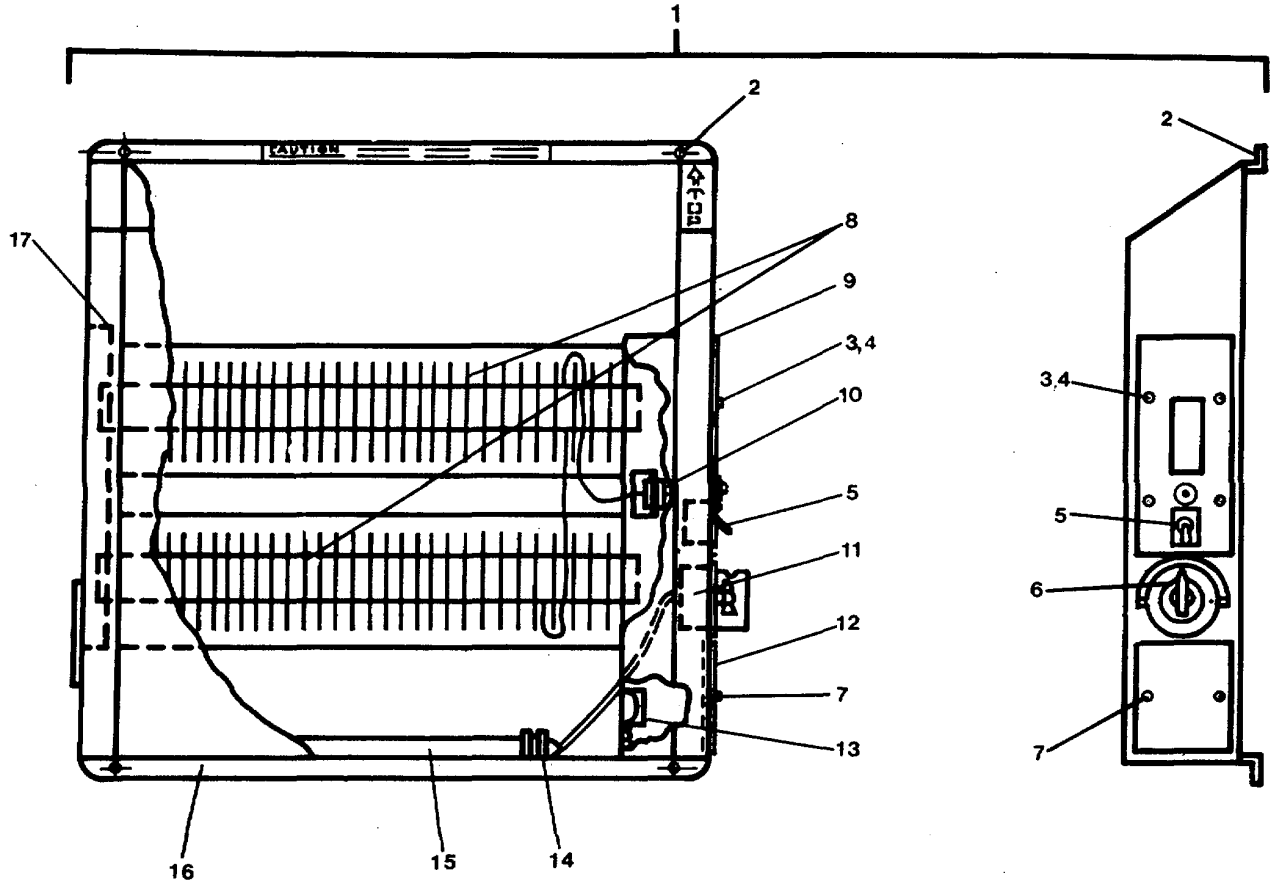

Figure 3-7. Convection Heater (CH #1 thru #4).

- c. Replace thermostatic switch (11) and knob (6):
- (1) Remove knob (6) from thermostatic switch.
 - (2) Remove cover (16) for access to switch and sensing element (15).
 - (3) Remove clamp (14) from sensing element (15).
 - (4) Remove thermostatic switch (11) with element (15).
 - (5) Install new switch with element (15) in place.
 - (6) Install cover (16).
 - (7) Install knob (6) on thermostatic switch.
- d. Replace terminal block (13):
- (1) Remove screws (7) from terminal box cover (12).
 - (2) Remove terminal box cover (12) for access to terminal block (13).
 - (3) Tag and disconnect electrical wiring from terminal block (13).
 - (4) Remove terminal block.
 - (5) Install new terminal block (13).
 - (6) Connect electrical wiring to terminal block.
 - (7) Install terminal box cover (12) with screws (7).
- e. Replace heating elements (8):
- (1) Remove screws (2) and cover (16) for access to elements (8).
 - (2) Tag and disconnect electrical wiring from elements.
 - (3) Remove elements (8) from element support (17).
 - (4) Install new elements in support (17).
 - (5) Connect electrical wiring to heating elements (8).
 - (6) Install cover (16) on heater (1) with screws (2).
- f. Operational check:
- (1) Turn electrical power ON.
 - (2) Start and run heater to check operation.
 - (3) Remove "Out of Service" tag from circuit.

3-17. Repair Fan, Ventilating (Supply Fan #3). (FIGURE 3-8)

This task covers:**a. Removal****b. Repair****c. Replacement**

INITIAL SETUP:Tools

Tool kit, general mechanic's,
5180-00-699-5273
Tool kit, electrician's,
5180-00-391-1087

Materials/Parts

Tag, Item 1, Appendix C
Ventilating Fan P/N 44-12-DG2
Bushing P/N 402000010
Impeller P/N 6518700Z0

Equipment Condition

Circuit breaker switched OFF, power
panel locked and tagged "Out of
Service - Do Not Operate."

See TM 55-1905-223-10 for HVAC systems
operation and equipment.

REMOVAL**WARNING**

Make sure electrical power is OFF to avoid personal injury.

- a. Turn power OFF.
- b. Tag and disconnect electrical wiring to the fan.
- c. Remove mounting hardware (5, 6, 11, 12) from each end of the fan (1). This will disconnect the fan from companion flange (7) on each end of ducting.
- d. Remove the fan unit.

REPAIR

- a. With the fan unit removed, disconnect the vane section (4) of the fan unit (1) by removing mounting hardware (2, 3).
- b. Remove the impeller (9) from the shaft of the motor (10).
- c. Remove the bushing (8) from the impeller (9).

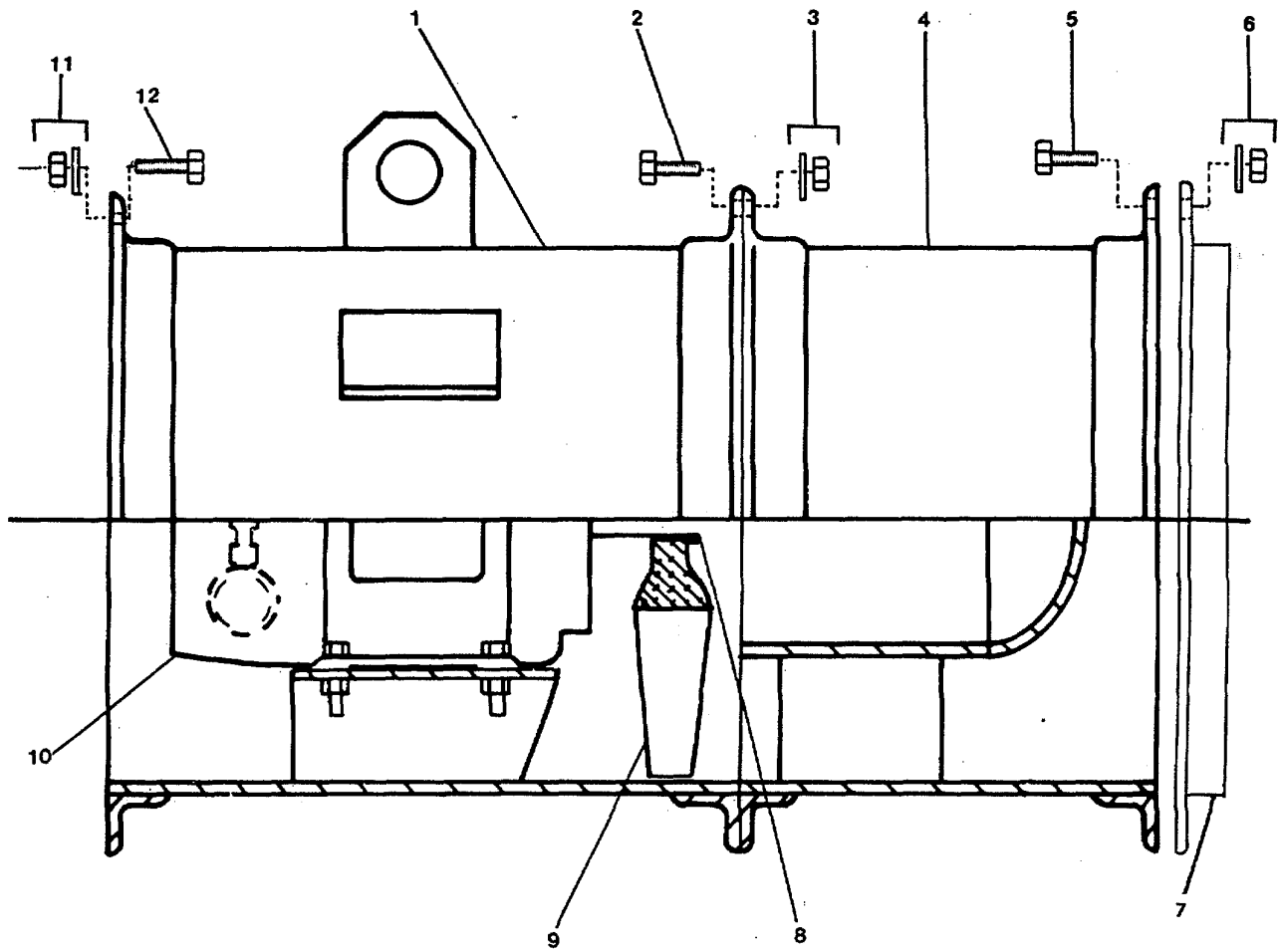

Figure 3-8 . Ventilating Fan (Supply Fan #3) .

- d. Install new bushing (8) into impeller (9).
- e. Install impeller onto shaft of motor (10).
- f. Connect the vane section (4) to main body of fan unit (1) with mounting hardware (2, 3).
- g. Install fan (REPLACEMENT step in this procedure).

REPLACEMENT

- a. Install fan unit (1) to companion flanges (7) on ducting with mounting hardware (5, 6, 11, 12).
- b. Connect electrical wiring to fan.
- c. Operational checks:
 - (1) Turn electrical power ON.
 - (2) Start and run fan to check operation.
 - (3) Remove "Out of Service" tag from circuit.

3-18. Repair Motor, Electric, Alternating Current (SF #3). (FIGURE 3-9)

This task covers:

a. Removal

b. Repair

c. Replacement

INITIAL SETUP:

Tools

Tool kit, general mechanic's,
5180-00-699-5273
Tool kit, electrician's,
5180-00-391-1087

Materials/Parts

Tag, Item 1, Appendix C
Alternating current electric motor
P/N 311890750
Motor stator P/N 311890750-2
Motor rotor P/N 311890750-3
Shaft P/N 311890750-6
Bearings P/N 416821-2D
Woodruff key P/N 311890750-21

Equipment Condition

Circuit breaker switched OFF, power
panel locked and tagged "Out of
Service - Do Not Operate."

See TM 55-1905-223-10 for HVAC systems
operation and equipment.

REMOVAL

WARNING

Make sure electrical power is OFF to avoid personal injury.

- a. Remove ventilating fan, vane section, and impeller (paragraph 3-17).
- b. Tag and disconnect electrical wiring to motor jack box (20).
- c. Disconnect lubricating tubes from grease entries (4, 13).
- d. Remove mounting bolts (19) from motor base.
- e. Remove the motor (1) from the fan unit.

REPAIR

Repair consists of replacing motor bearings.

- a. Disassemble motor as follows:

- (1) Remove Woodruff key (15) from shaft spline.
- (2) Remove bolt (17) and remove back end bracket (11) and dirt deflector (14).
- (3) Remove fan cover bolt (7) and remove fan cover (2). Remove grease entry tube (4) from bracket (5).
- (4) Remove fan clamp (24) and remove outer fan (3) from motor shaft (16).
- (5) Remove front end bracket bolt (6) and remove front end bracket (5). Remove washer (23).
- (6) Remove the shaft (16) and rotor (10) from the motor.
- (7) Make the following measurements and record:
 - (a) Measure the distance from back bearing (12) to the impeller end of the shaft (16).
 - (b) Measure the distance from front bearing (22) to the outer fan (3) end of the shaft (16).
- (8) Use puller and remove bearings (12, 22) from shaft.

b. Assemble motor as follows:

- (1) Install new bearings (12, 22) on shaft (16):
 - (a) Make sure the collars are facing each other on the shaft.
 - (b) Refer to measurements recorded and place bearings on shaft in same positions as old bearings that were removed.
- (2) Install the shaft (16) and bearings (12, 22) assembly into the motor.
- (3) Install washer (23) and front end bracket (5). Install bracket bolt (6).
- (4) Install outer fan (3) on motor shaft and install fan clamp (24).
- (5) Align grease entry tube (4) and install fan cover (2). Install fan cover bolt (7).
- (6) Install back end bracket (11) and dirt deflector (14). Install bolt (17).
- (7) Position Woodruff key (15) in shaft spline.
- (8) Install motor (1) onto fan unit.

REPLACEMENT

- a. Position motor (1) on fan unit and install mounting bolts (19).
- b. Connect lubricating tubes to grease entries (4, 13).

- c. Connect electrical wiring in motor jack box (20).
- d. Install impeller and vane section. Install ventilating fan unit (paragraph 3-17).
- e. Operational check:
 - (1) Turn electrical power ON.
 - (2) Start and run fan motor to check operation.
 - (3) Remove "Out of Service" tag from circuit.

3-19. Repair Fan, Ventilating (Supply Fan #4). (FIGURE 3-10)

This task covers:

a. Repair

INITIAL SETUP:

Tools

Tool kit, general mechanic's,
5180-00-699-5273
Tool kit, electrician's,
5180-00-391-1087

Equipment Condition

Circuit breaker switched OFF, power
panel locked and tagged "Out of
Service - Do Not Operate."

See TM 55-1905-223-10 for HVAC systems
operation and equipment.

Materials/Parts

Tag, Item 1, Appendix C
Impeller P/N 783078-36
Bearings P/N 716625-03
Shaft P/N 717189-01
Grease lines P/N 716661-02
Bushings P/N 725539-14
Fan bushing P/N 725409-10

REPAIR

WARNING

Make sure electrical power is OFF to avoid personal injury.

- a. Remove ventilating fan (paragraph 2-26).
- b. Remove electric motor (1) and V-belt (19) from fan unit (paragraphs 2-26 thru 2-28).
- c. Replace grease lines (7):
 - (1) Disconnect the two grease lines (7) on the inside and outside of fan drum (6).
 - (2) Install new grease lines (7) to inside and outside fittings on fan drum (6).
- d. Replace impeller (3), fan bushing (4), and machine key (16):
 - (1) Remove impeller nosepiece (2).
 - (2) Remove impeller (3) and machine key (16) from fan shaft (15).

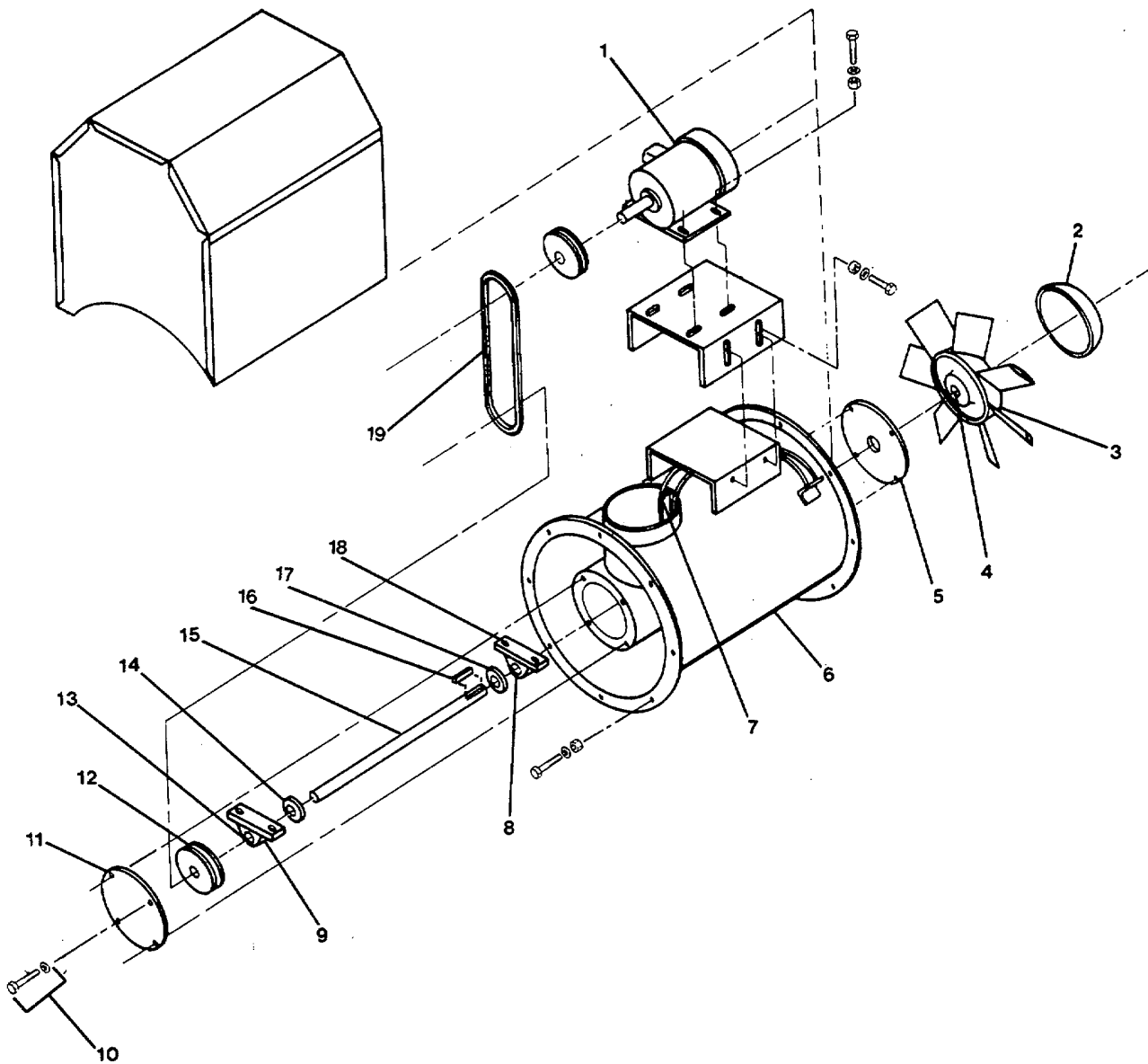

Figure 3-10. Ventilating Fan (Supply Fan #4).

- (3) Using drift pin, remove bushing (4) from impeller (3).
- (4) Install new bushing (4) into impeller (3).
- (5) Insert machine key (16) in shaft (15) spline.

- (6) Install impeller onto fan shaft (15).
 - (7) Install nosepiece (2) onto impeller.
- e. Replace bearings (9, 18), bushings (8, 13), and fan shaft (15).
- (1) Disassemble parts as follows:
 - (a) Remove impeller (3) with bushing (4) (REPAIR, step d., above).
 - (b) Remove impeller end cover (5).
 - (c) Remove bolts and washers (10) and remove drive end cover (11).
 - (d) Remove fan sheave (12) from fan shaft (15).
 - (e) Remove mounting bolts from bearings (9, 18) and slide the shaft and bearings assembly from the fan drum (6).
 - (f) Remove bearings (9, 18) and collars (14, 17) from fan shaft (15).
 - (g) Remove bushings (8, 13) from bearings (9, 18).
 - (2) Assemble parts as follows:
 - (a) Install new bushings (8, 13) in bearings (9, 18).
 - (b) Install collars (14, 17) and bearings (9, 18) onto fan shaft (15).
 - (c) Position shaft and bearings assembly inside fan drum (6). Install bearings (9, 18) mounting bolts.
 - (d) Install fan sheave (12) onto fan shaft (15).
 - (e) Install drive end cover (11) with bolts and washers (10).
 - (f) Install propeller end cover (5).
 - (g) Install impeller (3) and bushing (4) (REPAIR, step d., above).
- f. Install electric motor (1) and V-belt (19) (paragraphs 2-25 thru 2-27).
- g. Install ventilating fan (paragraph 2-26).
- h. Operational check:
- (1) Turn electrical power ON.
 - (2) Start and run fan to check operation.
 - (3) Remove "Out of Service" tag from circuit.

3-20. Repair Motor, Electric, Alternating Current (SF #4, #5, and #6), (EF #3, #4, and #6) (FIGURE 3-11)

This task covers:

a. Repair

INITIAL SETUP:

Tools

Tool kit, general mechanic's,
5180-00-699-5273

Tool kit, electrician's,
5180-00-391-1087

Materials/Parts

Tag, Item 1, Appendix C
Crocus cloth (fine)
Item 5, Appendix C
Rags, Item 6, Appendix C

Equipment Condition

Circuit breaker switched OFF, power
panel locked and tagged "Out of
Service - Do Not Operate."

Electric motor removed,
(para. 2-26 for SF-4).
(para. 2-27 for SF-5),
(para. 2-29 for SF-6),
(para. 2-30 for EF-3),
(para. 2-31 for EF-4 and -6).

See TM 55-1905-223-10 for HVAC systems
operation and equipment.

REPAIR

Repair is by sanding windings or replacing motor.

WARNING

Make sure electrical power is OFF to avoid personal injury.

- a. Visually check the stator windings inside motor housing (2) for signs of burning.
- b. Visually check rotor (3) for signs of burning.
- c. If stator windings or rotor show signs of burning, replace the electric motor (paragraphs listed in INITIAL SETUP, above).
- d. Check rotor fan (4) and external fan (5) for bent or broken blades. If blades are bent or broken, replace the electric motor (paragraphs listed in INITIAL SETUP, above).
- e. Lightly sand the rotor (3), and stator plates inside housing (2), with fine crocus cloth.

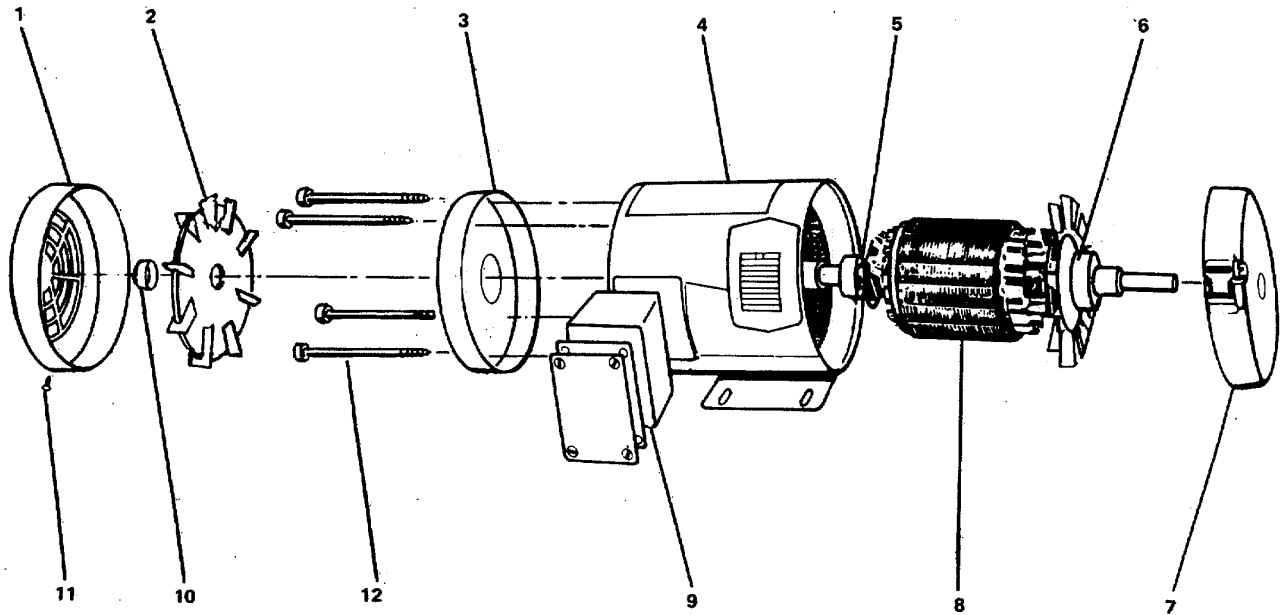

Figure 3-11. Alternating Current Motor (SF #4, #5, and #6).
(EF #3, #4, and #6) .

- f. Wipe rotor and stator plates with a clean rag to remove dirt and sanding residue.
- g. Assemble electric motor (paragraph 2-26).
- h. Install electric motor and V-belt (paragraphs 2-25 through 2-27).
- i. Operational check:
 - (1) Turn electrical power ON.
 - (2) Start and run fan motor to check operation.
 - (3) Remove "Out of Service" tag from the circuit.

3-21. Repair Fan, Ventilating (Supply Fan #5). (FIGURE 3-12)

This task covers:

a. Repair

INITIAL SETUP:

Tools

Tool kit, general mechanic's,
5180-00-699-5273
Tool kit, electrician's,
5180-00-391-1087

Equipment Condition

Circuit breaker switched OFF, power
panel locked and tagged "Out of
Service - Do Not Operate."
See TM 55-1905-223-10 for HVAC systems
operation and equipment.

Materials/Parts

Tag, Item 1, Appendix C
Front box guard P/N 716654-01
Impeller P/N 603921-01

REPAIR

WARNING

Make sure electrical power is OFF to avoid personal injury.

- a. Remove box guard (5) from ventilating fan (1) (paragraph 2-26).
- b. Visually check the box guard (5) for dented guard material (6). Remove dents by bending or hammering as necessary. Refer to paragraph 2-27 for removing and replacing guard.
- c. Visually check impeller (4) for bent or broken blades. Replace ventilating fan if blades are bent or broken (paragraph 2-31).
- d. For repair of ac motor, refer to paragraph 3-20.
- e. Install guard (5) on ventilating fan (1) (paragraph 2-27).
- f. Operational check:
 - (1) Turn electrical power ON.
 - (2) Start and run fan to check operation.
 - (3) Remove "Out of Service" tag from circuit.

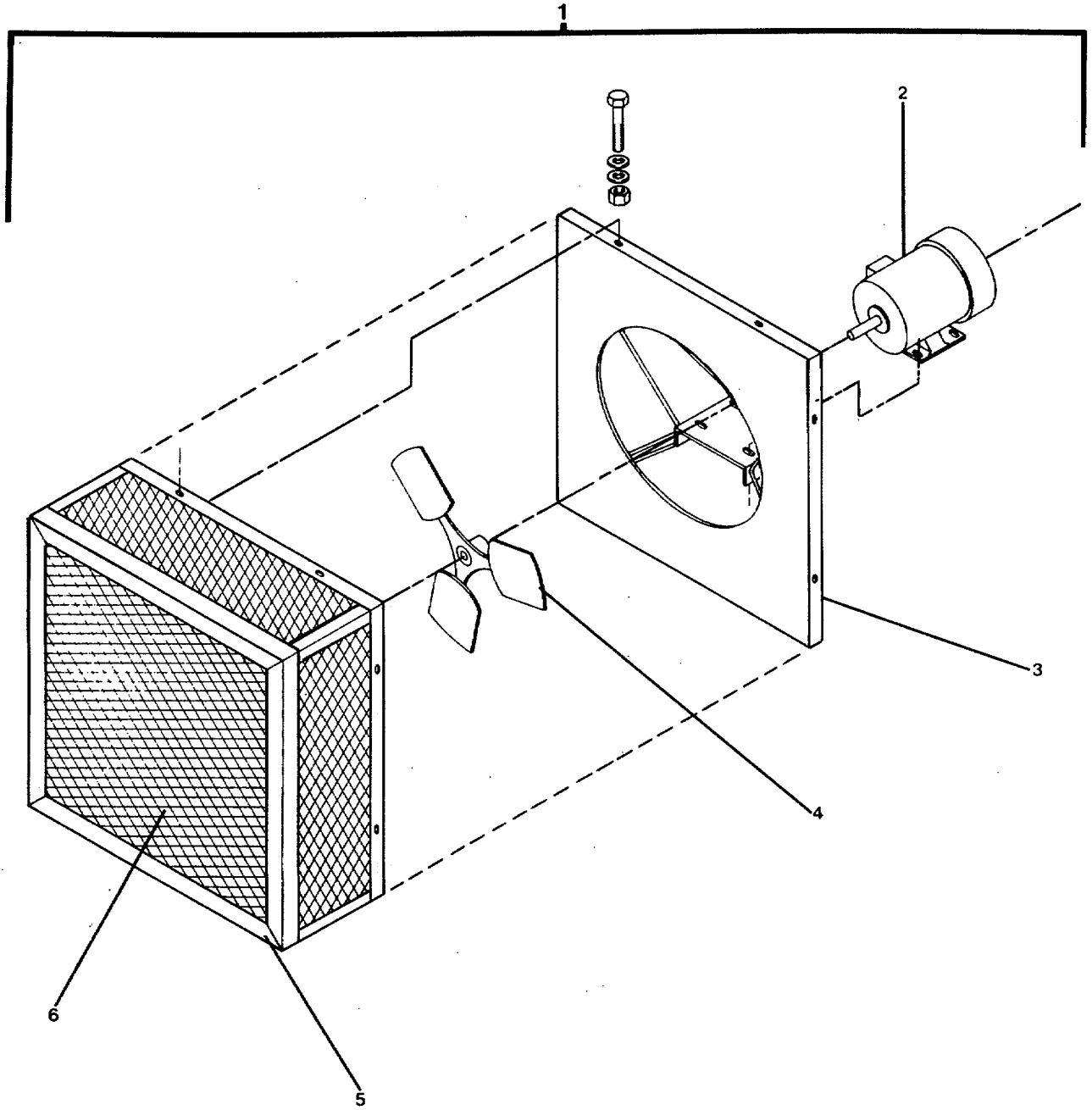

Figure 3-12. Ventilating Fan (Supply Fan #5).

3-22. Repair Fan, Ventilating (Supply Fan #6). (FIGURE 3-13)

This task covers:

a. Repair

INITIAL SETUP:

Tools

Tool kit, general mechanic's,
5180-00-699-5273
Tool kit, electrician's,
5180-00-391-1087

Materials/Parts

Tag, Item 1, Appendix C
Fan impeller P/N 782952-00
Bearings P/N 716625-01
Straight shaft P/N 100206-04

Equipment Condition

Circuit breaker switched OFF, power panel locked and tagged "Out of Service - Do Not Operate."
Ventilating fan removed (para. 2-27).
Electric motor and V-belt removed (para. 2-29).
See TM 55-1905-223-10 for HVAC systems operation and equipment.

REPAIR

WARNING

Make sure electrical power is OFF to avoid personal injury.

a. Replace fan impeller (3):

- (1) Loosen set screw holding impeller (3) onto shaft (10).
- (2) Slide impeller (3) from fan shaft (10).
- (3) Remove finger ring (4) from shaft (10).
- (4) Install finger ring (4) onto shaft (10).
- (5) Install new impeller onto fan shaft (10).

b. Replace unit ball bearings (9) and straight shaft (10).

- (1) Disassemble parts as follows:
 - (a) Remove impeller (3) and finger ring (4) (REPAIR, step d., above).
 - (b) Remove bolts and washers (8) and remove bearing cover (7) and gasket strip (6) from inside fan drum (5).
 - (c) Remove fan sheave (11) from straight shaft (10).

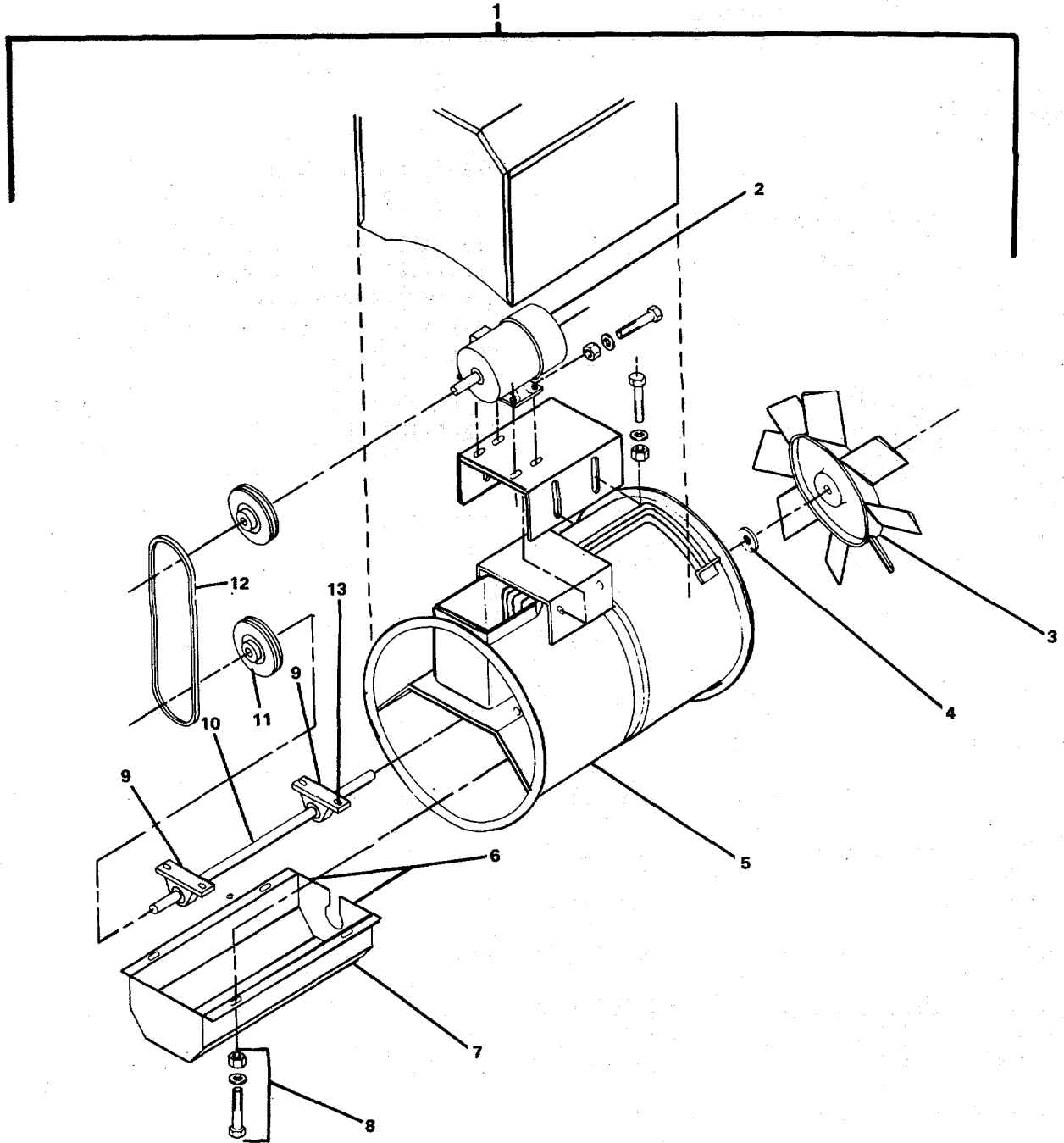

Figure 3-13. *Ventilating Fan (Supply Fan #6)* .

- (d) Remove mounting bolts from bearings (9) and slide the straight shaft and bearings assembly from the fan drum (5).
- c. Remove bearings (9) from straight shaft (10).
 - (1) Assemble parts as follows:
 - (a) Install bearings (9) onto straight shaft (10).
 - (b) Position shaft and bearings assembly inside fan drum (5). Install bearing (9) mounting bolts (13).
 - (c) Install fan sheave (11) onto straight shaft (10).
 - (d) Install gasket strip (6) and bearing cover (7) with bolts and washers (8).
 - (e) Install impeller (3) and finger ring (4) (REPAIR, step d., above).
- d. Install electric motor (2) (paragraph 2-28).
- e. Install ventilating fan and V-belt (12) (paragraph 2-27).
- f. Operational check:
 - (1) Turn electrical power ON.
 - (2) Start and run fan to check operation.
 - (3) Remove "Out of Service" tag from circuit.

3-23. Repair Fan, Ventilating (Exhaust Fan #3). (FIGURE 3-14)

This task covers:

a. Repair

INITIAL SETUP:

Tools

Tool kit, general mechanic's,
5180-00-699-5273
Tool kit, electrician's,
5180-00-391-1087

Equipment Condition

Circuit breaker switched OFF, power
panel locked and tagged "Out of
Service - Do Not Operate."
Ventilating fan removed (para. 2-28).
See TM 55-1905-223-10 for HVAC systems
operation and equipment.

Materials/Parts

Tag, Item 1, Appendix C
Crocus cloth (fine),
Item 5, Appendix C
Impeller P/N 783076-51

REPAIR

WARNING

Make sure electrical power is OFF to avoid personal injury.

- a. Remove impeller (3) from shaft of motor (2).
- b. Check impeller (3) for bent or broken blades. Replace as required.
- c. Using drift pin, remove bushing (4) from impeller.
- d. Sand the end of the motor shaft lightly with fine crocus cloth to remove dirt, grease, or corrosion.
- e. Install bushing (4) in impeller (3).
- f. Install impeller onto shaft of motor (2).
- g. Install ventilating fan (1) (paragraph 2-29).
- h. Operational check:
 - (1) Turn electrical power ON.
 - (2) Start and run fan to check operation.
 - (3) Remove "Out of Service" tag from circuit.

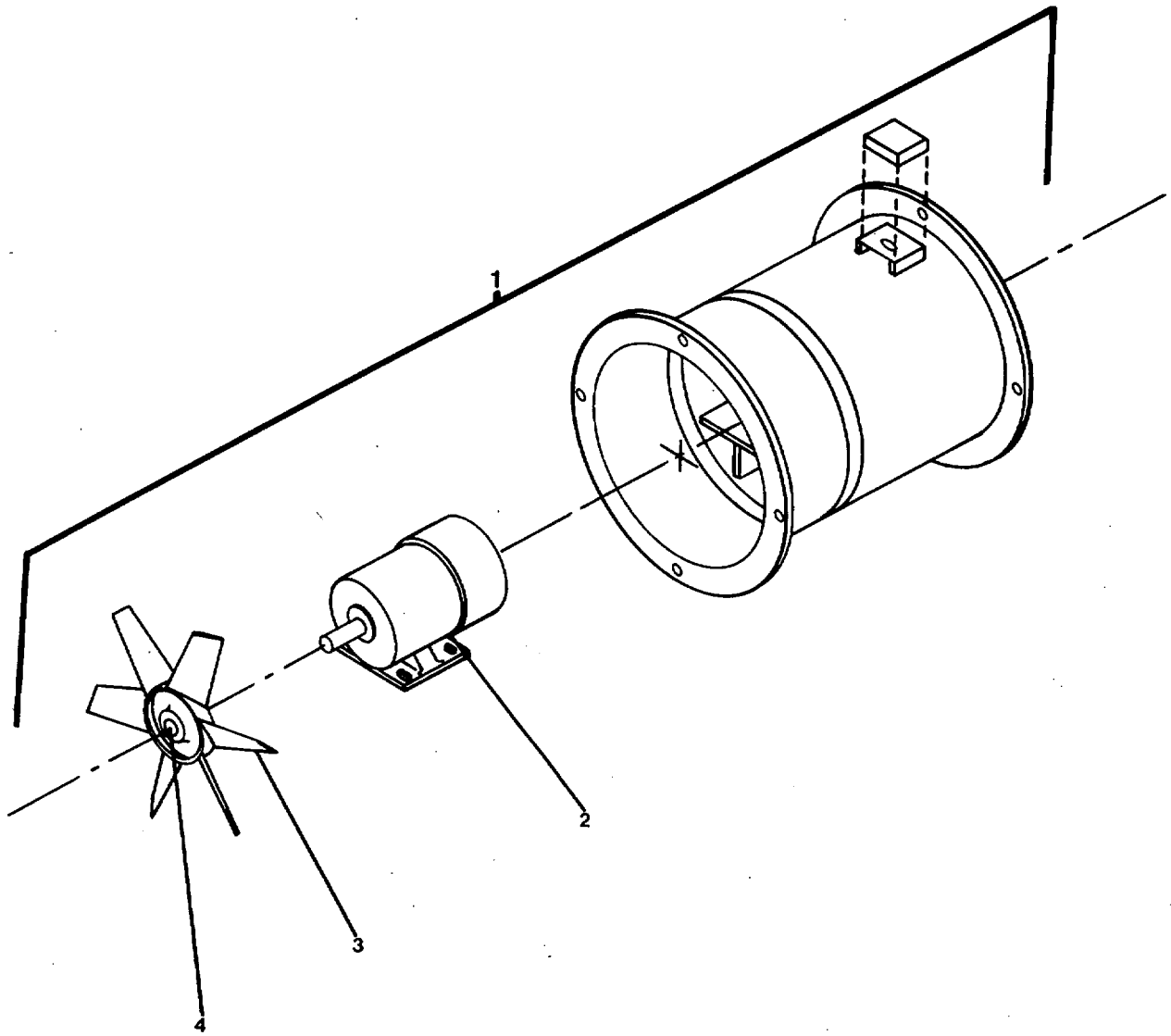

Figure 3-14. Ventilating Fan (Exhaust Fan #3).

3-24. Repair Fan, Ventilating (Exhaust Fans #4 and #6). (FIGURE 3-15)

This task covers:

a. Repair

INITIAL SETUP:

Tools

Tool kit, general mechanic's,
5180-00-699-5273

Tool kit, electrician's,
5180-00-391-1087

Materials/Parts

Tag, Item 1, Appendix C
Fan sheave bushing P/N 725409-10
Machine key P/N 100500-01
Flanged bearings
P/N 100730-01
Shaft P/N 100914-01
Machine key P/N 100500-49

Equipment Condition

Circuit breaker switched OFF, power
panel locked and tagged "Out of
Service - Do Not Operate."

Ventilating fan weather cover, inlet
and outlet flange, and V-belt removed
(para. 2-31).

See TM 55-1905-223-10 for HVAC systems
operation and equipment.

REPAIR

WARNING

Make sure electrical power is OFF to avoid personal injury.

- a. Remove ventilating fan weather cover (1), inlet flange (4), and outlet flange (5) (paragraph 2-35).
- b. Remove V-belt (13) (paragraph 2-35).
- c. Replace machine key (12):
 - (1) Remove motor sheave (14) and machine key (12) from shaft of motor (15).
 - (2) Install new machine key (12) in motor shaft spline.
 - (3) Install motor sheave (14) on shaft of motor (15).
- d. Replace straight shaft (8), flanged bearings (7), fan sheave bushing (10), and machine key (11):
 - (1) Remove inlet cone (3) from housing (6).

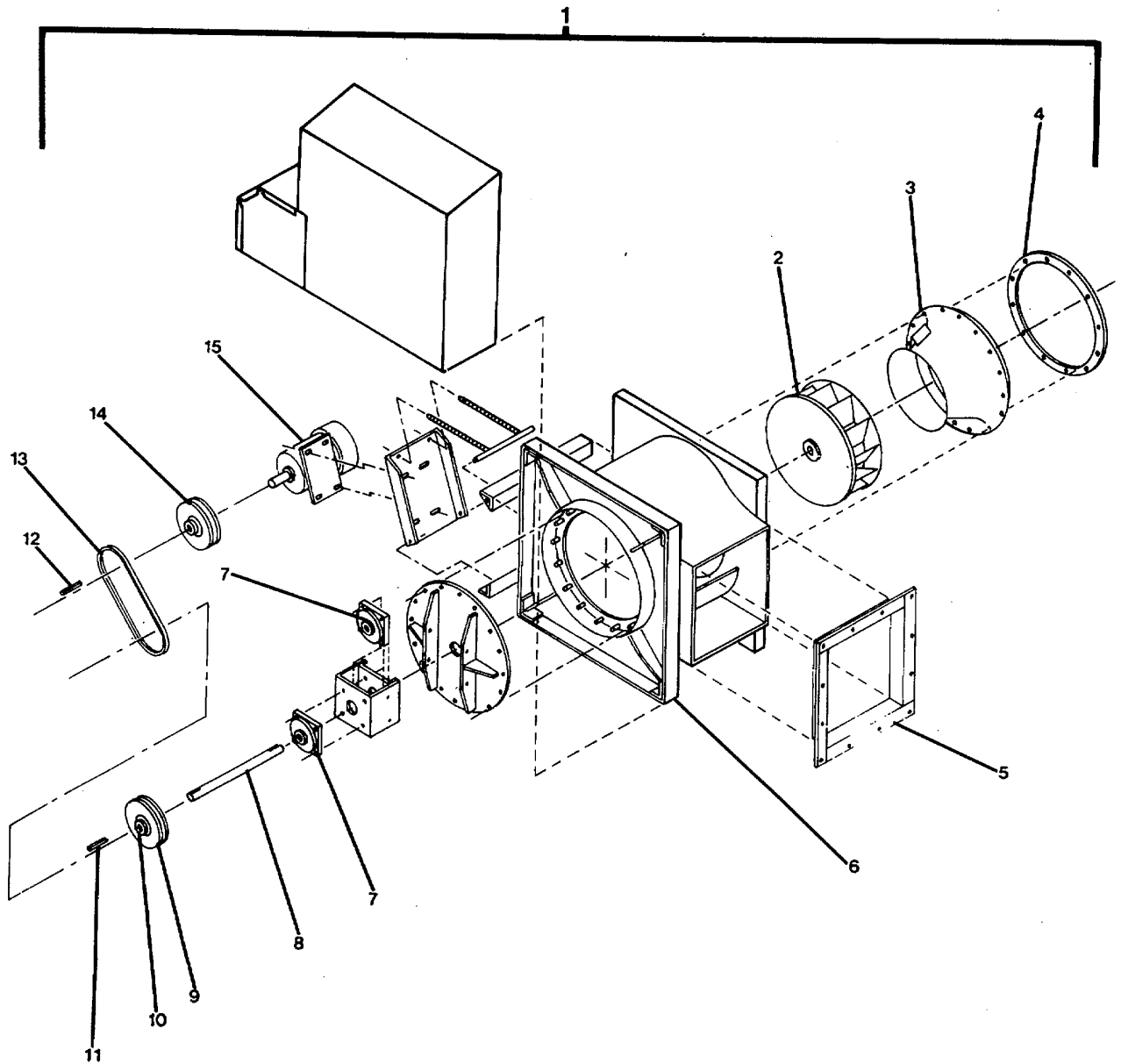

Figure 3-15. Ventilating Fans (Exhausts Fan #4 and #6).

- (2) Remove blower wheel (2) from straight shaft (8).
 - (3) Remove fan sheave (9) and machine key (11) from straight shaft (8).
 - (4) Using drift pin, remove fan sheave bushing (10) from fan sheave (9).
 - (5) Remove straight shaft (8) and the two flanged bearings (7).
 - (6) Install new flanged bearings (7) and straight shaft (8).
 - (7) Install new fan sheave bushing (10) in fan sheave (9).
 - (8) Install machine key (11) and fan sheave (9) on straight shaft (8).
 - (9) Install blower wheel (2) on straight shaft (8).
 - (10) Install inlet cone (3) on housing (6).
- e. Install and adjust V-belt (13) (paragraph 2-31).
- f. Install inlet flange (4), outlet flange (5) and ventilating fan (1) (paragraph 2-31).
- g. Operational check:
- (1) Turn electrical power ON.
 - (2) Start and run fan to check operation.
 - (3) Remove "Out of Service" tag from circuit.

3-25. Repair Air Conditioner (A/C-1, Pilothouse), (A/C-3, Engine Control Room).

This task covers:

a. Removal

b. Repair

d. Replacement

INITIAL SETUP:

Tools

Tool kit, general mechanic's,
5180-00-699-5273
Tool kit, electrician's,
5180-00-391-1087
Tool kit, refrigeration and air
conditioning, TM 5180-00-596-1474

Equipment Condition

Circuit breaker switched OFF, power
panel locked and tagged "Out of
Service - Do Not Operate. "

See TM 55-1905-223-10 for HVAC systems
operation and equipment location

Materials/Parts

Tag, Item 1, Appendix C
Rags, Item 6, Appendix C
Air conditioner P/N 45KC 33D
Compressor P/N 020-A-109
Contactor P/N 025-A-009
Transformer P/N 025-A-241
Blower motor P/N 050-A-046
Motor capacitor P/N 017-A-009
Electric motor (condensate pump)
P/N 050-A-106
Condensate pump P/N SA 057-A-022
Electromagnetic relay P/N 059-A-119
High pressure switch P/N 066-A-039
Water bypass valve P/N 068-A-038
Water regulating valve
P/N 068-A-098

REMOVAL

WARNING

Make sure electrical power is OFF to avoid personal injury.

- a. Tag and disconnect electrical wiring from terminal box (8, FIGURE 3-16).
- b. Close external seawater inlet and outlet valves.
- c. Disconnect water outlet line connection (6).

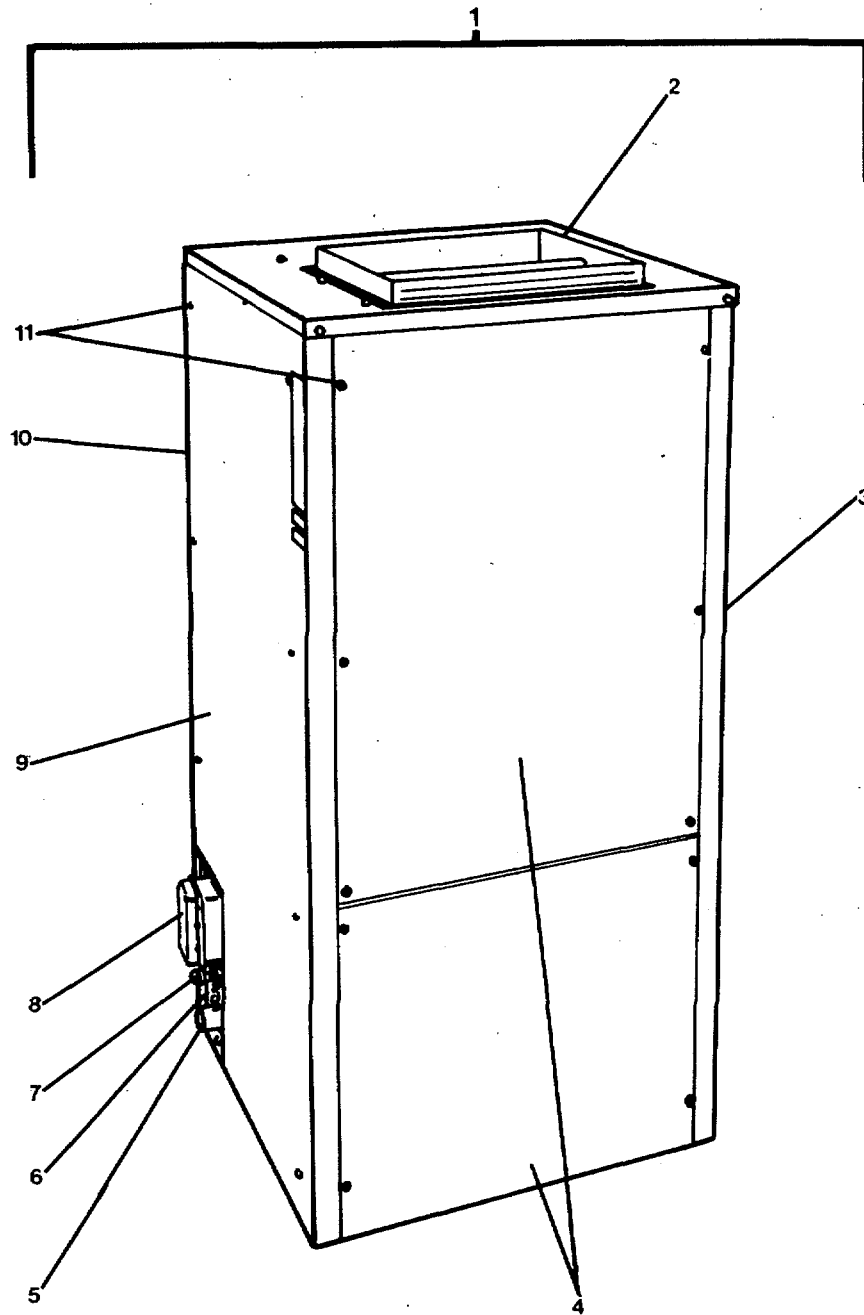

Figure 3-16. Self-Contained Air Conditioner (A/C-1 and 3)

- d. Disconnect water inlet line connection (7).
- e. Disconnect condensate drain connection (5).
- f. Disconnect ducting from back of unit (10).
- g. Remove ducting from blower flange (2) on top of the unit.
- h. Remove the air conditioner (1).

REPAIR

WARNING

Make sure electrical power is OFF to avoid personal injury.

- a. Remove panel screws (11, FIGURE 3-16) to remove side panels (3, 9) and/or front panel (4) for access to internal components.
- b. Replace contactor (15, FIGURE 3-17), transformer (16), or electromagnetic relay (17) as follows:
 - (1) Tag and disconnect electrical wiring to defective component.
 - (2) Remove defective contactor (15), transformer (16) or electromagnetic relay (17).
 - (3) Install new contactor (15), transformer (16), or electromagnetic relay (17) as appropriate.
 - (4) Connect electrical wiring to proper terminals on the new component.
- c. Replace capacitor (5) and blower motor (3) as follows:

WARNING

Discharge capacitor before handling to prevent electrical shock.

- (1) Removal.
 - (a) Ground the terminals of the capacitor (5) with an insulated screwdriver to discharge any stored electrical charge.
 - (b) Tag and disconnect electrical wiring to capacitor (5) and blower motor (3). Remove cable ties from motor mounting bracket.
 - (c) Remove capacitor (5).
 - (d) Loosen the setscrew holding the blower wheel on the shaft of motor (3) from inside housing (2).

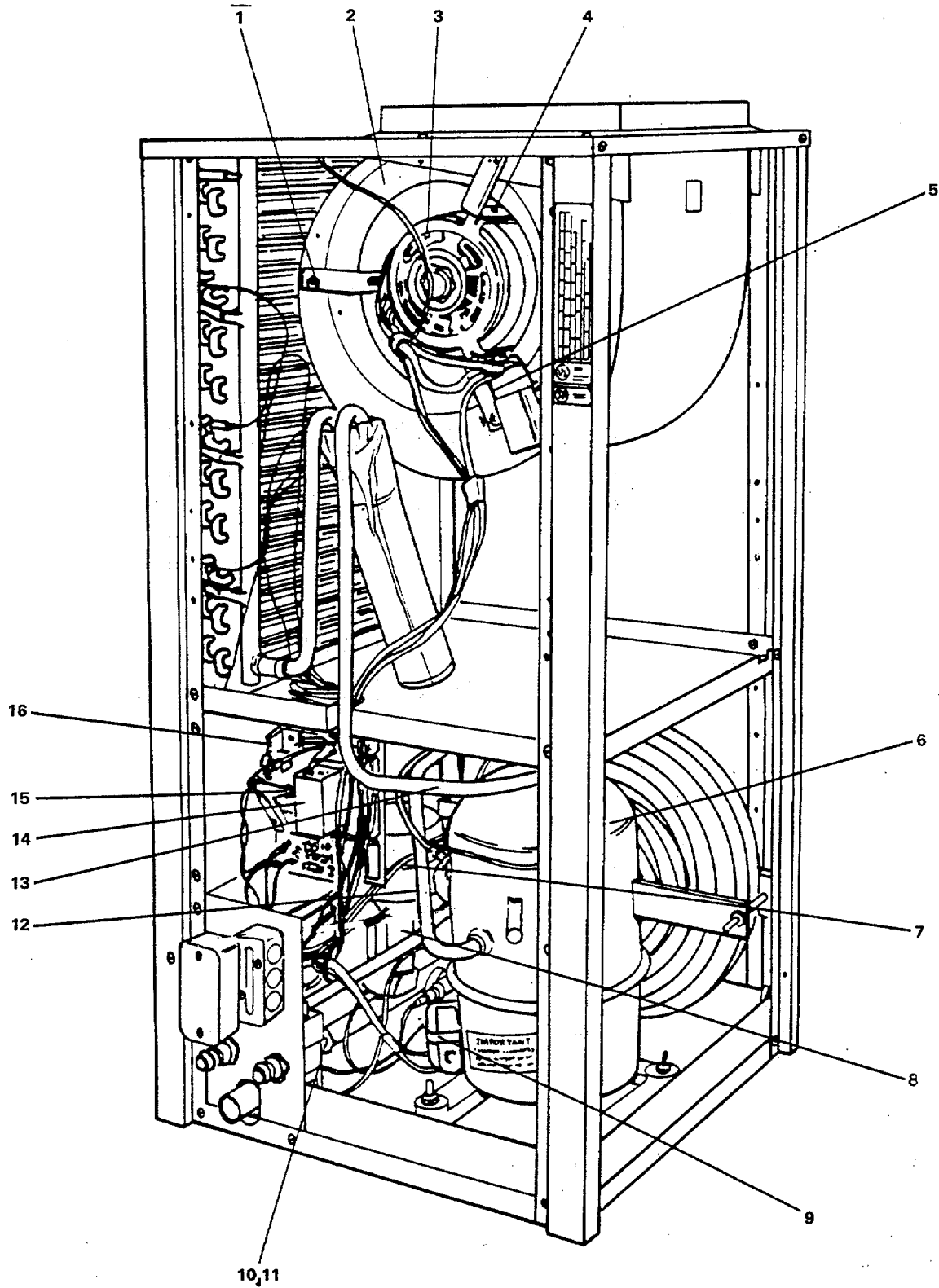

Figure 3-17. Air Conditioner Components (A/C-1 and 3).

- (e) Remove the three mounting screws (1) and slide motor (3) out of housing (2).
- (f) Remove mounting bracket (4) from motor (3).
- (2) Replacement.
 - (a) Install mounting bracket (4) to motor (3).
 - (b) Align motor shaft with blower wheel on inside of housing (2). Slide motor into blower housing (2) and install mounting screws (1).
 - (c) Make sure the blower wheel is not rubbing against the housing. Tighten blower wheel setscrew firmly on motor shaft.
 - (d) Install new capacitor (5).
 - (e) Install cable ties to mounting bracket in their original positions.
 - (f) Connect electrical wiring to proper terminals on capacitor (5) and motor (3).
- d. Replace condensate pump (8) and motor (7) as follows:
 - (1) Tag and disconnect electrical wiring to electric pump motor (7).
 - (2) Disconnect pump (8) from drain piping.
 - (3) Remove the motor and pump assembly from the air conditioning unit.
 - (4) Remove pump (8) from motor (7).
 - (5) Install new pump to motor.
 - (6) Install pump and motor assembly.
 - (7) Connect pump (8) to drain piping.
 - (8) Connect electrical wiring to proper terminals on motor (7).
- e. Replace high pressure switch (9) as follows:
 - (1) Remove switch cover.
 - (2) Tag and disconnect electrical wiring to switch.
 - (3) Remove switch from mounting.
 - (4) Install new switch (9).
 - (5) Connect electrical wiring to proper terminals.
 - (6) Install switch cover.

- f. Replace water bypass (10) and water regulating valve (11) (see paragraph 1-17f) as follows:
- (1) Tag and disconnect electrical wiring from water bypass (10) and water regulating valve (11).
 - (2) Close external seawater inlet and outlet valves.
 - (3) Disconnect the seawater inlet and outlet connections (6, 7, FIGURE 3-16) and drain condenser.
 - (4) Remove the water bypass and water regulating valves (10, 11, FIGURE 3-17).
 - (5) Install water bypass and water regulating valves (10, 11).
 - (6) Connect seawater inlet and outlet lines to connections (6, 7, FIGURE 3-16).
 - (7) Open external seawater inlet and outlet valves.
 - (8) Connect electrical wiring to proper terminals on water bypass and water regulating valves (10, 11, FIGURE 3-17).
- g. Replace compressor (6) as follows:
- (1) To remove compressor (6):
 - (a) Remove all refrigerant (freon) from system Item 12, Table 2-2.
 - (b) Tag and disconnect electrical wiring to compressor.
 - (c) Measure the amount of discharge tubing (13) and suction tubing (12) that is attached and is not crimped to the new compressor to be installed.
 - (d) Using the measurements taken in step (c) above, measure the discharge tubing (13) and suction tubing (12) on the compressor being removed. Measure away from compressor. Deduct 3/4 inch from each measurement and place a mark on tubing.
 - (e) Use a tubing cutter and cut the discharge tubing (13) and suction tubing (12) at the points marked.
 - (f) Remove the three bolts with rubber mounts (6, FIGURE 3-18) from the base of the compressor (2) and remove the compressor from the unit.
 - (2) To install compressor (6, FIGURE 3-17):

WARNING

New compressor is hermetically sealed and contains a refrigerant charge. Release charge in a well ventilated area away from open flames. Avoid breathing vapors.

- (a) The ends of discharge and suction tubing on a new compressor may be crimped to seal in refrigerant charge. The tubing ends on the compressor will have to be cut and swagged if the ends are crimped.
- (b) If the tubing ends on new compressor are already swagged (4, FIGURE 3-18) and plugged, remove plugs (3) to release charge and continue with step h(2)(d) of this procedure.
- (c) Use a tubing cutter and cut the crimped ends. This will break the seal and release the refrigerant charge from the compressor.

CAUTION

Keep compressor in an upright position after opening seal. A new compressor will already have the proper amount of oil added. If compressor is tipped, oil will be lost by draining from the open discharge or suction line connection.

- (d) Using the swagging tool (1, FIGURE 3-18) from the refrigerant tool kit, swag the tubing ends (4) and (8) on the new compressor to proper size so that the suction line and discharge line will fit.
- (e) Position new compressor (2) on unit and install mounting bolts with rubber mounts (6).
- (f) Make sure the connections are free of dirt and grease.
- (g) Position the end of discharge tubing (13, FIGURE 3-17) to be connected into the swagged fitting on the end of compressor discharge tubing.
- (h) Position the end of suction tubing (14) to be connected into the swagged fitting on the end of compressor suction tubing.

CAUTION

Do not let solder or debris enter compressor line openings.

- (i) Solder each joint to connect discharge and suction line tubings.
- (j) Connect electrical wiring to proper terminals on compressor.

WARNING

PRESSURIZED GAS HAZARD. Handle R-22 refrigerant containers with care to avoid personal injury. Keep containers away from external heat sources. DO NOT DROP containers. When in use, place containers where they will not be knocked over.

- (k) Evacuate and charge the unit with R-22 refrigerant (Item 12, Table 2-2).

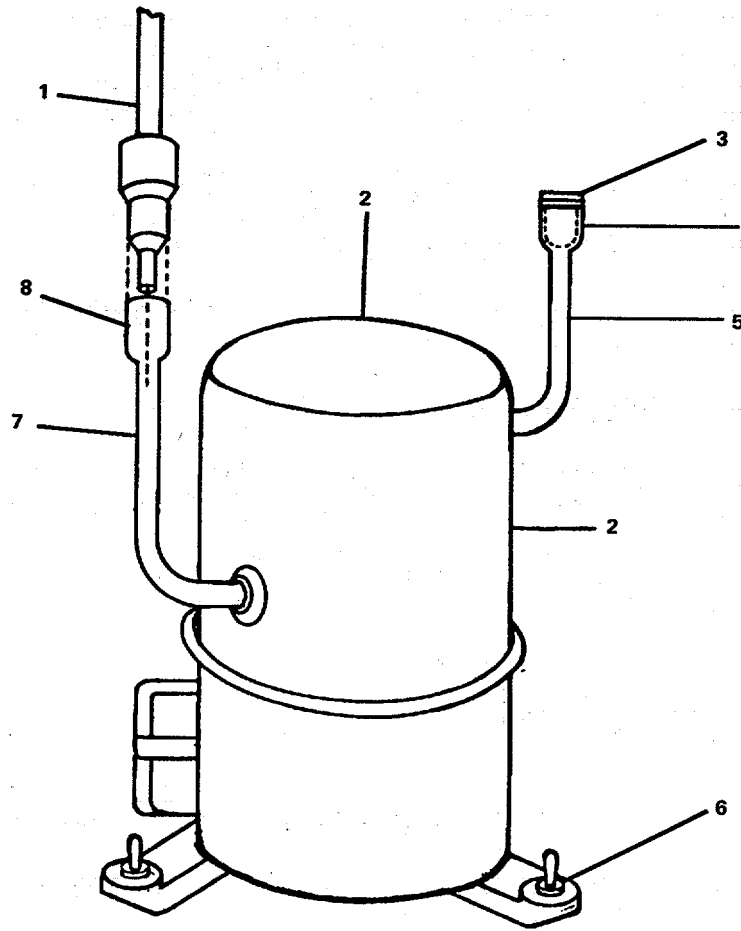

Figure 3-18. Swagging Compressor Tubing.

- h. Replace side panels (3, 9, FIGURE 3-16) and/or front panel (4) with panel screws (11).

REPLACEMENT

- a. Install air conditioner (1, FIGURE 3-17).
- b. Attach ducting to blower flange (2) on top of unit.
- c. Attach ducting to back of unit (10).
- d. Connect condensate line connection (5).
- e. Connect water inlet line connection (7).
- f. Connect water outlet line connection (6).
- g. Open external seawater outlet and inlet valves.
- h. Connect electrical wiring to proper connections in terminal box (8).
- i. Operational check:
 - (1) Turn electrical power ON.
 - (2) Start and run air conditioner to check operation.
 - (3) Remove "Out of Service" tag from circuit.

SECTION VI. PREPARATION FOR STORAGE OR SHIPMENT

3-26. Refer to Chapter 2, Section VI.

CHAPTER 4

INTERMEDIATE GENERAL SUPPORT MAINTENANCE INSTRUCTIONS

	Page
Section I. Repair Parts, Special Tools; Test, Measurement, and Diagnostic Equipment (TMDE); and Support Equipment.....	4-1
Section II. Service Upon Receipt.....	4-1
Section III. Intermediate General Support Preventive Maintenance Checks and Services (PMCS).....	4-2
Section IV. Intermediate General Support Troubleshooting.....	4-2
Section V. Intermediate General Support Maintenance Procedures.....	4-13
Section VI. Preparation for Storage or Shipment	4-77

SECTION I. REPAIR PARTS, SPECIAL TOOLS; TEST, MEASUREMENT, AND DIAGNOSTIC EQUIPMENT (TMDE); AND SUPPORT EQUIPMENT

- 4-1. Common Tools and Equipment. For authorized common tools and equipment, refer to the Modified Table of Organization and Equipment (MTOE) applicable to your organization.
- 4-2. Special Tools, TMDE, and Support Equipment. Special tools; test, measurement, and diagnostic equipment; and support equipment requirements are listed and illustrated in the Repair Parts and Special Tools List (RPSTL), TM 55-1905-223-24P. These items are also listed in the Maintenance Allocation Chart (MAC), Appendix B of this manual.
- 4-3. Repair Parts. Repair parts are listed and illustrated in the Repair Parts and Special Tools List (RPSTL), TM 55-1905-223-24P.

SECTION II. SERVICE UPON RECEIPT

- 4-4. Checking Unpacked Equipment.
 - a. Inspect the equipment for damage incurred during shipment. If the equipment has been damaged, report the damage in accordance with the instructions of DA Pam 738-750.
 - b. Check the equipment against the packing slip to see if the shipment is complete. Report all discrepancies in accordance with the instructions of DA Pam 738-750.
 - c. Check to see whether the equipment has been modified.

- d. Remove protective caps, plugs, inserts, wrappings, and tape when inspection/inventory is completed. Inspect piping openings for damage. Wipe off dirt, grease, or protective films at time of installation.
- e. Remove chocks from resilient mounted components.

4-5. Initial Setup Procedure. Includes operational checks and inspections that are not performed for a routine startup. Direct support maintenance personnel will perform initial setup in accordance with the operator's manual, TM 55-1905-223-10.

4-6. Normal Startup. Refer to the operator's manual, TM 55-1905-223-10.

4-7. Shutdown Procedure (Usual or Unusual). Refer to the operator's manual, TM 55-1905-223-10.

Section III. INTERMEDIATE GENERAL SUPPORT PREVENTIVE MAINTENANCE CHECKS AND SERVICES (PMCS)

4-8. PMCS. There is no PMCS at the general support level. See Chapter 2, Section III.

SECTION IV. INTERMEDIATE GENERAL SUPPORT TROUBLESHOOTING

4-9. Troubleshooting. Both a symptom index and a troubleshooting table are provided. The symptom index will help you locate the information you need for troubleshooting.

SYMPTOM INDEX	
Procedure	Troubleshooting (Table 4-1)
HEATING	
Excessive noise or vibration	Item 1
Fan does not operate	Item 2
AIR CONDITIONING	
Cold or frosted liquid line (or line component)	Item 9
Compressor crankcase cold (sweating or frosting)	Item 7
Compressor noises	Item 15
Compressor motor hums but does not start	Item 11
Compressor runs continuously	Item 14
Compressor short cycles on high pressure cut-out	Item 12
Compressor short cycles on low pressure cut-out	Item 13
Compressor will not start	Item 10

SYMPTOM INDEX - CONT

	Troubleshooting Procedure (Table 4-1)
High crankcase temperature (compressor extremely hot)	Item 8
High operating head (discharge) pressure	Item 3
High suction pressure	Item 5
Hissing sound	Item 16
Low operating head (discharge) pressure	Item 4
Lower than normal suction pressure	Item 6
No cooling - blower does not run	Item 17
No cooling - blower running	Item 18
Partial or insufficient cooling - blower running	Item 19

Table 4-1 lists the common fault conditions that may be found during operation or maintenance of the equipment. Look for causes and do corrective actions in the order listed. This manual cannot list every symptom that may show up, and it cannot list all of the possible causes and corrective actions. If a symptom is not listed, or if it keeps up after you have performed the corrective actions, notify your supervisor.

Table 4-1. Troubleshooting

Malfunction

Test or Inspection

Corrective Action

VENTILATION (SUPPLY AND EXHAUST FANS)

1. Excessive noise or vibration.
 - STEP 1. Impeller out of balance, worn, or corroded.
Replace impeller (paragraphs 4-11 through 4-13).
 - STEP 2. Check for worn or defective bearings.
Replace bearings as required (paragraph 4-12).

2. Fan does not operate.
 - STEP 1. Check for defective fan motor.
Replace fan motor (paragraph 4-12 or 4-13).
 - STEP 2. Check for defective controller.
Turn power on. If motor does not start, see TM 55-1905-223-24-18 for maintenance of controller.

Table 4-1. Troubleshooting - CONT

Malfunction	Test or Inspection	Corrective Action
AIR CONDITIONING		
3.	High operating head (discharge) pressure (above 230 psig).	<p data-bbox="248 449 886 478">STEP 1. Check to see if refrigerant is overcharged.</p> <p data-bbox="329 480 716 510">a. Remove excess refrigerant:</p> <p data-bbox="461 541 821 571" style="padding-left: 40px;"><u>A/C-2 (Accommodations unit).</u></p> <ol style="list-style-type: none"> <li data-bbox="461 602 1419 661">(1) Shut down compressor and connect a portable gauge manifold hook up as follows: <li data-bbox="461 693 1446 783">(2) Connect combination (suction) hoseline of the manifold to the suction service valve on the compressor. Connect the high pressure (discharge) hoseline of the manifold to the discharge valve on the compressor. <li data-bbox="461 814 1398 873">(3) Connect the common (middle) hoseline of the manifold to an empty R-22 refrigerant container. Open the valve on the empty container. <li data-bbox="461 905 1419 1029">(4) Make sure both gauge port handwheels on the manifold are closed fully clockwise. Start compressor and run while adjusting pressure. Open discharge and suction service valves on compressor three turns clockwise. Suction and discharge pressures will register on the gauge manifold. <li data-bbox="461 1060 1466 1184">(5) Crack open the gauge port handwheel on the high pressure (discharge) gauge on the manifold momentarily 2 to 3 seconds. Close handwheel and observe discharge pressure readings. Pressure should be between 170 and 230 psig. If not, repeat above procedure. <li data-bbox="461 1215 1390 1306">(6) When discharge pressure adjusted to proper level, close valve on R-22 container. Close (back-seat) discharge and suction service valves fully counterclockwise. <li data-bbox="461 1337 1459 1396">(7) Disconnect portable gauge manifold from compressor service valves and from R-22 container. <p data-bbox="248 1428 1471 1482">STEP 2. Check to see if compressor discharge stop valve partially closed (A/C-2; accommodations). Turn valve fully counterclockwise.</p>
4.	Low operating head (discharge) pressure (below 170 psig).	<p data-bbox="248 1581 1110 1610">STEP 1. Check for leaky compressor discharge or suction valve plate.</p>

Table 4-1. Troubleshooting - CONT

Malfunction	Test or Inspection	Corrective Action
-------------	--------------------	-------------------

AIR CONDITIONING - CONT

NOTE

A low discharge pressure (below 170 psig) combined with a high suction pressure (above 72 psig) indicates a leaky valve plate.

Replace valve plate in semi-hermetic compressor (A/C 2; accommodations) (paragraph 4-19).

STEP 2. Check for worn piston rings in semi-hermetic compressor (A/C-2 accommodations). Replace piston rings (paragraph 4-19).

5. High suction pressure (above 72 psig).

STEP 1. Check for clogged suction strainer in semi-hermetic type compressor (A/C-2). Remove and clean strainer (paragraph 4-19).

STEP 2. Check for leaky compressor suction valve plate. A higher than normal suction pressure combined with a discharge pressure lower than normal indicates a leaky valve plate. Replace compressor suction valve plate (paragraph 4-19).

6. Lower than normal suction pressure (below 58 psig).

STEP 1. Check to see if there is sufficient refrigerant.
 a. Add R-22 refrigerant as follows:

WARNING

PRESSURIZED GAS HAZARD. Handle R-22 refrigerant containers with care to avoid personal injury. Keep containers away from external heat sources. DO NOT DROP containers. When in use, place containers where they will not be knocked over.

A/C-2 (Accommodations).

(1) Shut down compressor and connect a portable gauge manifold to the compressor. Connect combination (suction) gauge hose line to the suction service valve connection. Connect common (middle) hose line of manifold to a container of new R-22 refrigerant. Make sure container is in upright position. Purge all connecting hose lines. Turn on tank to crack hose fitting until refrigerant opens.

Table 4-1. Troubleshooting - CONT

Malfunction	Test or Inspection	Corrective Action
-------------	--------------------	-------------------

AIR CONDITIONING - CONT

- (2) Make sure both handwheels on the manifold are closed fully clockwise.
- (3) Start and run compressor for 5 minutes before continuing.

NOTE

The sight glass in the liquid line will show a stream of bubbles, or a foamy appearance, when the system is low on refrigerant.

- (4) Open the valve on the refrigerant container counterclockwise.
- (5) Open the suction service valve on the compressor three turns clockwise.
- (6) Watch the sight glass and slowly crack open the gauge port handwheel on the combination (suction) gauge momentarily for 1 to 2 seconds, adding a small amount of refrigerant. Close handwheel and observe sight glass condition.
- (7) If bubbles are still present, repeat cracking and closing combination with gauge handwheel until sight glass shows a clear condition. Do not continue to add refrigerant once the sight glass has cleared.
- (8) When sight glass has cleared, close (back-seat) service valve fully counterclockwise.
- (9) Close valve on refrigerant container fully clockwise.
- (10) Shut down compressor and disconnect gauge manifold from refrigerant container and suction service valve.

STEP 2. Check for clogged suction strainer in semi-hermetic type compressor (A/C-2). Remove and clean suction strainer (paragraph 4-19).

7. Compressor crankcase cold (sweating or frosting).

STEP 1. Check to see if refrigerant is overcharged. Remove excess refrigerant (Malfunction 3).

STEP 2. Check to see if operating thermostat is set too low or is defective. Adjust thermostat. Replace thermostat if defective (paragraph 4-14).

Table 4-1. Troubleshooting - CONT

Malfunction	Test or Inspection	Corrective Action
-------------	--------------------	-------------------

AIR CONDITIONING - CONT

8. High crankcase temperature (compressor extremely hot).
- STEP 1. Check for clogged suction strainer in semi-hermetic type compressor (A/C-2).
- a. Remove motor end cover and strainer.
 - b. Remove and clean suction strainer (paragraph 4-19).
9. Cold or frosted liquid line (or component in the liquid line).
- STEP 1. Check for restriction in the liquid line, or component, at the point of frost or temperature difference.
- a. Replace frosted ball check valves (paragraph 4-14).
 - b. Check and replace other liquid line component as required.
- STEP 2. Check for non-condensables in system.
Purge, or evacuate, and recharge with R-22 (Malfunction 4, or paragraph 4-10).
10. Compressor will not start.
- STEP 1. Check to see if low pressure control switch is open due to low refrigerant charge (A/C-2; accommodations).
- a. Check for blown pressure relief valve. Determine cause and replace valve (paragraph 4-14).
 - b. Repair any leaks, evacuate, and recharge system with R-22 as follows:
 - (1) Leak test refrigerant line and components:

WARNING

Turn electrical power OFF.

- (2) With the unit shutdown, use the refrigerant gas leak detector in the refrigeration tool kit and check all lines and components in the system for leaks.

NOTE

Leaks commonly occur in defective joints, fittings, gaskets, and in breaks caused by vibration.

Table 4-1. Troubleshooting - CONT

Malfunction	Test or Inspection	Corrective Action
-------------	--------------------	-------------------

AIR CONDITIONING - CONT

- (3) If refrigerant has been lost due to a leak and pressure is below 175 psig, add enough R-22 refrigerant to system so that pressure is increased 175 psig before checking for leaks (Malfunction 6). Locate and correct required.

WARNING

Pump down, or remove, refrigerant before opening the system for repairs.

- (4) Pump down, or remove, the refrigerant charge as required by corrective action.
- (5) After corrective action complete, add R-22 refrigerant (Malfunction 3) or remove charge, evacuate, and recharge system (paragraph 4-10) as appropriate.
- (6) Pump down the system (A/C-2 only):

WARNING

PRESSURIZED GAS HAZARD. The refrigerant charge in the system can be pumped down and isolated into the condenser and receiver ONLY. If it is necessary to gain access to components in discharge line from compressor, including the discharge valve, the refrigerant charge must first be removed from the system to avoid personal injury.

NOTE

If the condenser, receiver or any other large component is removed, the system must be discharged and put under a vacuum for at least 6 hours.

- (7) With the unit operating, close the refrigerant line outlet valve from the receiver.

Table 4-1. Troubleshooting - CONT

Malfunction	Test or Inspection	Corrective Action
-------------	--------------------	-------------------

AIR CONDITIONING - CONT

NOTE

The low pressure control solenoid must be bypassed to allow unit to operate below normal pressure.

- (8) Watch the operating pressure on the combination (suction pressure) gauge. When pressure has dropped to 2 inches of vacuum on the gauge, stop the compressor. If the pressure rises rapidly, there is still residual refrigerant in the compressor. Start compressor and again pump pressure down to 2 inches of vacuum and stop compressor. If pressure remains at 1 or 2 inches of vacuum, or rises very slowly, close the compressor discharge (service) valve fully clockwise.

WARNING

Turn electrical power OFF.

- (9) If pressure remains in a vacuum, secure electrical power to the compressor and crack the outlet valve from the receiver momentarily to introduce sufficient refrigerant to obtain only a slight positive pressure of 1-2 psig to prevent air from being sucked into the system when opened.

WARNING

Do not open system with pressure exceeding 2 psig on the combination (suction pressure) gauge.

- (10) When a slight positive pressure of 1-2 psig is maintained, the liquid line, low pressure side of the system (including cooling coil/evaporator), and the compressor can be opened for maintenance and service.
- (11) When maintenance is completed, slowly open the refrigerant outlet- valve from the receiver. Open the discharge (service) valve on the compressor fully counterclockwise.
- (12) Restore electrical power, start and run the air conditioner assembly to check operation.

Table 4-1. Troubleshooting - CONT

Malfunction	Test or Inspection	Corrective Action
AIR CONDITIONING - CONT		
11.	Compressor motor hums but does not start.	STEP 1. Check to see if compressor motor is defective. Replace if "short" or "open" in windings (paragraph 4-19).
12.	Compressor short cycles on high pressure cut-out.	STEP 1. Check to see if compressor discharge stop service valve is partially closed (A/C-2; accommodations). Turn valve fully (counterclockwise). STEP 2. Check to see if high (discharge) pressure control (solenoid) is defective. Check for defective control. Replace as required (paragraph 4-14). STEP 3. Check for air or non-condensables in system. Purge, (Malfunction 4). If purging is not successful, remove charge, evacuate, and recharge system with R-22 (paragraph 4-10).
13.	Compressor short cycles on low pressure cut-out.	STEP 1. Check for shortage of refrigerant. Find and repair leak. Evacuate and recharge system with R-22 (Malfunction 10 and paragraph 4-10). STEP 2. Check to see if suction stop (service) valve is partially closed (A/C-2; accommodations). Turn valve fully counterclockwise. STEP 3. Check to see if suction strainer is clogged on semi-hermetic type compressor (A/C-2; accommodations). Remove and clean debris from strainer (paragraph 4-9).
14.	Compressor runs continually.	STEP 1. Check for shortage of refrigerant. Find and repair leak. Evacuate and recharge system with R-22 (Malfunction 10 and paragraph 4-10) STEP 2. Check to see if compressor discharge valve leaks (A/C-2; accommodations).

NOTE

A low discharge pressure (below 170 psig) combined with a high suction pressure (above 72 psig) indicates a leaky valve plate.

Table 4-1. Troubleshooting - CONT

Malfunction	Test or Inspection	Corrective Action
AIR CONDITIONING - CONT		
		Replace valve plate in semi-hermetic compressor in A/C-2 (paragraph 4-9).
STEP 3.	Check to see if thermostat is stuck.	Replace thermostat (paragraph 4-14).
STEP 4.	Check for leaking piston rings or cylinder sleeves in semi-hermetic type compressor (A/C-2; accommodations).	Replace piston rings or compressor as required (paragraph 4-19).
15.	Compressor noises.	
STEP 1.	Check for slugging due to refrigerant floodback (on expansion valve equipped unit; A/C-2, accommodations).	Make sure the thermal bulb on the expansion valve is firmly attached to the suction line. Correct as required.
STEP 2.	Check for hydraulic knock due to excess oil in circulation.	Refer to Item 14 of this table.
STEP 3.	Check for worn pistons, connecting rods, or bearings in semi-hermetic compressor (A/C-2; accommodations).	Replace as required (paragraph 4-9).
16.	Hissing sound.	
STEP 1.	Check for insufficient refrigerant flow due to low charge.	Find and repair leak. Evacuate and recharge system with R-22 (Malfunction 10 and paragraph 4-10).
17.	No cooling - blower does not run.	
STEP 1.	Check for fan motor defective.	Replace fan motor (paragraph 4-15).
18.	No cooling - blower running.	
STEP 1.	Check for air in system.	Purge, (Malfunction 4). If purging is not successful, remove charge, evacuate, and recharge system with R-22 (paragraph 4-10).

Table 4-1. Troubleshooting - CONT

Malfunction	Test or Inspection	Corrective Action
-------------	--------------------	-------------------

AIR CONDITIONING - CONT

19. Partial or insufficient cooling - blower running.
- STEP 1. Check for low refrigerant charge. Find and repair leak. Evacuate, recharge system with R-22 (Malfunction 10 and paragraph 4-10).
- STEP 2. Check for air in system. Purge (Malfunction 4). If purging is unsuccessful, remove charge, or evacuate, and recharge with R-22 (paragraph 4-10).
- STEP 3. Check to see if wrong refrigerant is in the system.
- a. Make certain R-22 only was added to the system. If not, purge. If purging is not successful, remove refrigerant, evacuate, and recharge with R-22 (paragraph 4-10).
- b. Purge non-condensables (A/C-2 only):
- (1) Stop compressor but allow seawater to continue passing through condenser. Allow compressor to cool for 10 minutes.

WARNING

PRESSURIZED GAS. Open valve slowly to avoid rapid release of refrigerant gas. Avoid contact with released gas and pressure.

- (2) Crack open the discharge (service) valve on the compressor very slowly (clockwise). Allow only a small amount of vapor to be released for 2 seconds. Close the discharge valve fully counterclockwise.
- (3) Start the compressor and check to see if the discharge pressure is still above 230 psig. If so, operate the compressor for 5 minutes and repeat the purging procedure. Normally, purging 3 or 4 times will remove non-condensables.

SECTION V. INTERMEDIATE GENERAL SUPPORT MAINTENANCE PROCEDURES**MAINTENANCE OF ENVIRONMENTAL CONTROL SUBSYSTEM**

4-10. Removing Charge, Evacuating System, and Recharging. For A/C-2, accommodations unit, use the following procedures to remove refrigerant charge, evacuate, and recharge with R-22 refrigerant:

- a. Remove Refrigerant Charge (A/C-2).
 - (1) Shut down the compressor.
 - (2) Connect a portable gauge manifold hookup as follows:
 - (3) Make sure both gauge port handwheels on the manifold are closed fully clockwise.
 - (4) Remove the protective valve stem caps on the suction and discharge service valves.
 - (5) Connect the combination (suction) hoseline from gauge manifold to the suction service valve on the compressor. Connect the high pressure hoseline from gauge manifold to the discharge service valve on the compressor. Connect the common (middle) hoseline from gauge manifold to the valve of an empty steel R-22 storage cylinder.

WARNING

PRESSURIZED GAS HAZARD. Handle R-22 refrigerant containers with care to avoid personal injury. Keep containers away from external heat sources. DO NOT DROP containers. When in use, place containers where they will not be knocked over.

- (6) Place the empty R-22 container upright in a larger open container (bucket) of cold water. Add ice as necessary to keep water cold while removing charge.

CAUTION

Either drain condenser completely or keep water flowing through condenser constantly in order to prevent freeze-up while removing refrigerant.

- (7) The system contains 30 lb of R-22 refrigerant. Make sure to obtain enough empty containers to hold the refrigerant being removed. Make sure to weigh each empty container and record the weight before removing refrigerant.

- (8) If compressor is inoperative, or system cannot be operated, use the migration method given for the self-contained units (A/C-1 and 3), except, connect gauge manifold to both suction and discharge valves and open both handwheels on the manifold when letting refrigerant pass into empty container.

WARNING

DO NOT overfill R-22 containers.

NOTE

Both service valves must be opened clockwise three or four turns when using the above migration method.

The migration method may be a slow process.

- (9) When using any method of removing refrigerant the R-22 container must be weighed periodically to make sure it is not being overfilled.
- (10) When possible, use the system compressor to remove refrigerant charge as follows:
- (a) Connect the gauge manifold from the compressor discharge valve service port to the refrigerant container and purge the lines. Note the maximum allowable refrigerant container weight.
 - (b) Place the refrigerant container in ice. Place the compressor in normal system operation. Turn the discharge service valve in a few turns to open the service port, open the refrigerant container valve and the gauge manifold so that discharge gas can enter the cold container, with the discharge pressure registering on the manifold high pressure gauge.

WARNING

DO NOT close the valve on the receiver outlet.

WARNING

DO NOT OVERFILL CONTAINER. Use additional containers as necessary.

- (c) A portion of the discharge gas will now enter the container and condense. Weigh the container frequently to check the progress in filling. Continue bypassing a portion of the discharge gas into the refrigerant container until it is filled to its weight capacity. Use additional containers as necessary.
- (d) When a major portion of the refrigerant has been removed, system pressures may fall so low that refrigerant can no longer be efficiently transferred. To remove the remainder of the refrigerant, disconnect the refrigerant cylinder and vent the remaining refrigerant to the atmosphere.

(11) Once the charge has been removed, the system can be opened for maintenance.

b. Evacuate System (A/C-2).

CAUTION

Make sure the oil level in the compressor is at the half-way point in the observation window before evacuating.

- (1) Use a refrigeration vacuum pump and a portable gauge manifold to evacuate the system.
- (2) Make sure both handwheels on the gauge manifold are closed fully clockwise.
- (3) Connect combination (suction) hoseline from manifold to suction service valve on compressor. Connect high pressure hoseline from the manifold to the discharge service valve on the compressor. Open both service valves by turning stems three or four turns clockwise.
- (4) Connect the common (middle) hoseline from the manifold to the suction connection of a vacuum pump.
- (5) Make sure all hoseline connections are secure.
- (6) Start and run the vacuum pump. Slowly open both gauge port handwheels on the manifold counterclockwise.

NOTE

It may be necessary to restrict the vacuum pump suction pressure by means of the gauge port handwheels to avoid overloading the vacuum pump motor.

Evacuation of system may be a slow process.

- (7) Continue running vacuum pump until a reading of 18 inches vacuum is obtained on both gauges (or to the limit of the vacuum pump's ability).
- (8) When evacuation is complete, close both gauge port handwheels on the manifold fully clockwise. Stop the vacuum pump.
- (9) Leave the gauge manifold connected and wait 15 minutes. Check pressure readings.
- (10) If the vacuum has been lost, or if you were unable to obtain a vacuum initially, there is loose hoseline connection or a leak in the system. Check hoseline connections.
- (11) Test for leak (Item 10, Table 3-1) and repeat the above evacuation procedure.

- (12) Once you are able to maintain a vacuum reading on the gauges, disconnect the common hoseline from the vacuum pump and connect it to a container of R-22.
- (13) Loosen the common hoseline connection at the gauge manifold momentarily, crack the refrigerant container valve to purge the hose, and retighten the hose connection.
- (14) Crack the valve on the refrigerant container. Crack the valves (handwheels) on the gauge manifold until the system pressure rises to 2 psig. Close the valve on the refrigerant container and both handwheels on the manifold.
- (15) Disconnect the common hoseline from the R-22 container and reconnect it to the suction connection on the vacuum pump.
- (16) Start the vacuum pump, slowly open both handwheels on the manifold, and again evacuate the system to 18 inches vacuum (or to limit of pump's ability).
- (17) Close both handwheels on the manifold, stop the vacuum pump, and wait 15 minutes to see that a vacuum is held.
- (18) When a vacuum is maintained, disconnect the common hoseline from the vacuum pump.
- (19) The system is now ready to recharge.

c. Recharge System (A/C-2).

- (1) The system holds 30 lb of R-22 refrigerant.

WARNING

PRESSURIZED GAS HAZARD. Handle R-22 refrigerant containers with care to avoid personal injury. Keep containers away from external heat sources. DO NOT DROP containers. When in use, place containers where they will not be knocked over.

NOTE

It may take more than one container of refrigerant to fill the system.

- (2) Use the scale from the refrigeration tool kit and weigh the R-22 refrigerant container, or containers, before charging. Make sure you have enough refrigerant on hand to fill the system. Record the container(s)' weight.
- (3) Make sure both service valves are open clockwise three or four turns before charging. The high pressure side is used for observing discharge pressure only. Do not add refrigerant through the discharge service valve.

- (4) With the system evacuated, and gauge manifold still hooked to compressor, connect the common hoseline of the manifold to a R-22 refrigerant container.
- (5) Crack the valve on the R-22 container momentarily and then close. Loosen the common hoseline connection at the manifold to purge the hose, then re-secure the connection.

WARNING

Do not use water warmer than 110°F to avoid over-expansion of refrigerant in container.

- (6) Place the refrigerant container upright in a container of warm water that is no, warmer than 110°F. This will maintain container pressure and expedite charging.

WARNING

DO NOT apply heat with a torch.

- (7) Start the compressor. Slowly open the low side handwheel on the combination gauge. DO NOT open the high side handwheel. Charging must be accomplished through the charging valve on the suction line.
- (8) Observe both gauges on the manifold while charging. Also observe the sight glass in the liquid line.
- (9) When operating pressures are within proper range (suction: 58-72 psig; discharge: 170-230 psig), close the combination low side handwheel on the manifold. Check the sight glass. If bubbles, or a stream of bubbles, are observed, crack the low side handwheel and add more refrigerant until sight glass clears. DO NOT continue adding after sight glass has cleared.
- (10) The actual weight of refrigerant added to the system can be determined by weighing the R-22 container(s) again and deducting the weight(s) obtained from initial weight(2) recorded before recharging.
- (11) If the result is in excess of the amount required by the unit's dataplate, secure the compressor and release a small amount of refrigerant. Close the valve on the R-22 container, make sure the handwheel on the combination gauge is closed, and disconnect the common hoseline from the R-22 container. Release a small amount of refrigerant by momentarily cracking the handwheel on the combination gauge. Take care not to release too much, or refrigerant may have to be added back.
- (12) Start the compressor, allow to run for 5 minutes, and again check operating pressures and sight glass.
- (13) When charging is complete, stop the compressor and close the suction and discharge service valves fully counterclockwise. Disconnect the gauge manifold and install protective caps on both service valve stems and gauge connections.

4-11. Replace/Repair Fan, Ventilating (Exhaust Fans 1 and 2). (FIGURE 4-1)

This task covers:

- | | | |
|-------------|----------------|-----------|
| a. Removal | b. Disassembly | c. Repair |
| d. Assembly | e. Replcaement | |
-

INITIAL SETUP:

Tools

Tool kit, general mechanic's
5180-00-699-5273
Tool kit, electrician's
5180-00-391-1087
Tool kit, refrigeration and
air conditioning,
5180-00-596-1474

Equipment Condition

Circuit breaker switched OFF, power
panel locked and tagged "Out of
Service - Do Not Operate."

See TM 55-1905-223-10 for HVAC SYSTEMS
operation and equipment location.

Materials/Parts

Warning tags, Item 1, Appendix C
Ventilating fan P/N 65-35-AV03
Axial fan impeller P/N 656503500

REMOVAL

WARNING

Make sure electrical power is OFF to avoid personal injury.

- a. Turn electrical power OFF.
- b. Tag and disconnect electrical wiring to the fan.
- c. Remove plain hexnuts, lockwashers, and flat washers (2 and 13) and hexhead screws and flat washers (3 and 12) from each end of the fan. This will disconnect the fan from the bell inlet (26) and companion flange (14) at each end of the fan. The fan will also be disconnected from the mounting feet (25) which hold the fan to the deck.
- d. Remove the fan (1).

DISASSEMBLY

- a. With the fan unit removed, disconnect outlet cone (15) from vane section (16) by removing plain hexnut, lockwasher, and flat washer (11) and hexhead screw and flat washer (10).

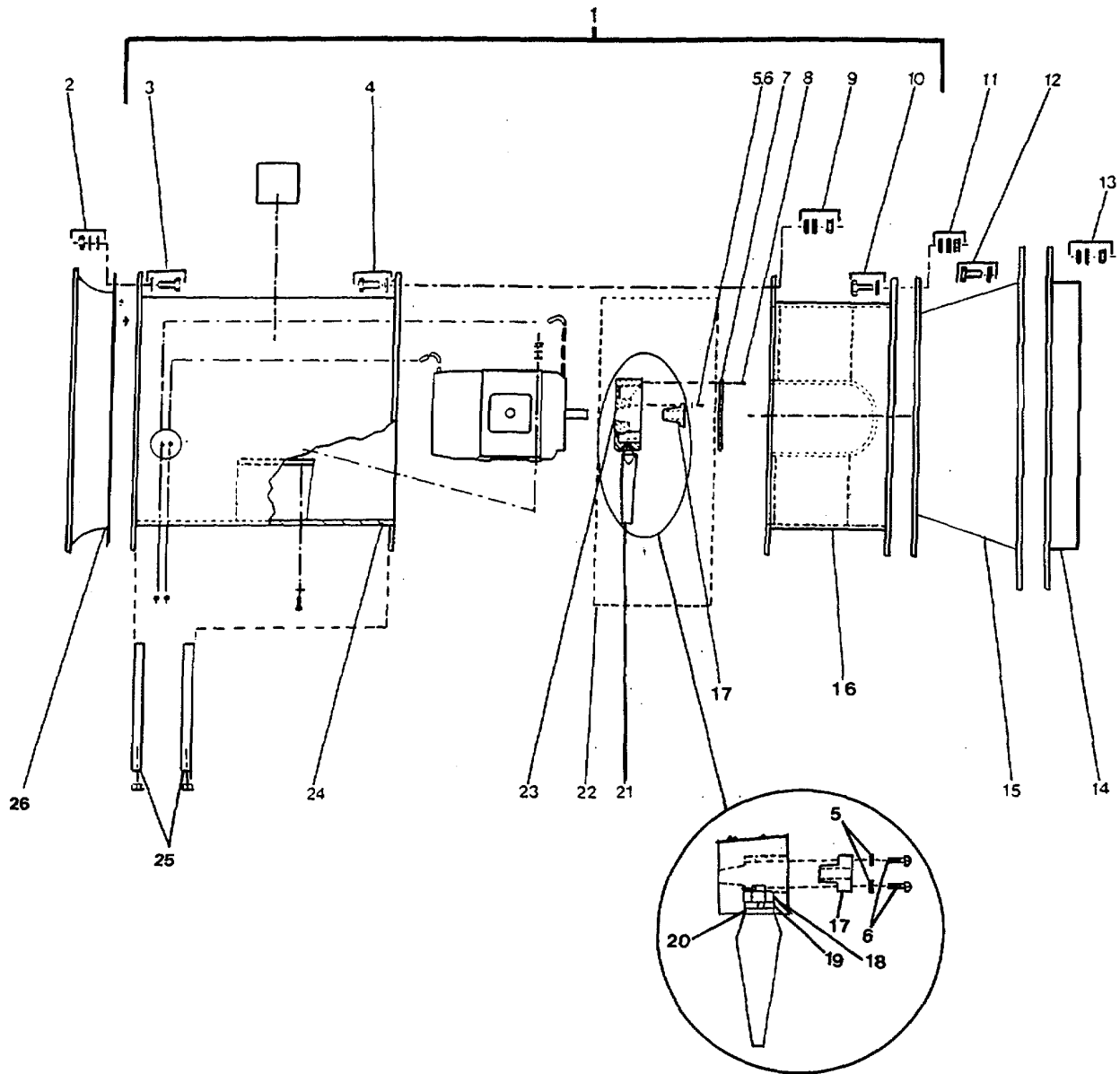

Figure 4-1 Ventilating Fan (Exhaust Fans 1 and 2)

- b. Disconnect vane section (16) from fan housing (24) by removing plain hexnut, lockwashers and flat washer (9) and hexhead screw and flat washer (4).
- c. Remove hub cover mounting screws (8) and remove hub cover (7).
- d. Remove bushing retaining screws and lockwashers (5, 6).
- e. Use a puller and remove fan hub (23).

REPAIR

Repair consists of replacing the axial fan impeller (22).

ASSEMBLY

- a. Press the fan hub (23) onto motor shaft.
- b. Install bushing retaining screws and lockwashers (6, 5).
- c. Install hub cover (7) with hub cover mounting screws (8).
- d. Connect vane section (16), to fan housing (24), connecting plain hexnut, lockwasher, and flat washer (9) to hexhead screw and flat washer (4).
- e. Connect outlet cone (15), to vane section (16), by connecting plain hexnut, lockwasher, and flat washer (11) to hexhead screw and flat washer (10).

REPLACEMENT

NOTE

Fans should always be mounted to flat, level, and rigid structure. Shim the fan where necessary. This will ensure permanent alignment and smooth-running and vibration-free fan.

- a. Position fan (1) and connect fan to bell inlet (26) and companion flange (14), and connect fan to deck mounting feet (25) by installing plain hexnuts, lockwashers, and flat washers (2 and 13) and hexhead screws and flat washers (3 and 12).
- b. Connect electrical wiring to fan.
- c. Operational Check:
 - (1) Turn electrical power ON.
 - (2) Start and run fan to check operation.
 - (3) Remove "Out of Service" tag from cir cuit.

4-12. Repair Motor, Electric, Alternating Current (EF #1 and #2) SF #1 and #2. (FIGURE 4-2).

This task covers:

- | | | |
|-------------|----------------|-----------|
| a. Removal | b. Disassembly | c. Repair |
| d. Assembly | e. Replacement | |

INITIAL SETUP:

Tools

Tool kit, general mechanic's,
5180-00-699-5273
Tool kit, electrician's,
5180-00-391-1087
Tool kit, refrigeration
and air conditioning,
5180-00-596-1474

Equipment Condition

Circuit breaker switched to OFF, power
panel locked and tagged "Out of
Service - Do Not Operate."
Vent. fan, outlet cone, vane section,
and impeller removed:
(para. 4-11 for exhaust fans 1 and 2)
(para. 4-13 for supply fans 1 and 2).

Materials/Parts

Warning tags, Item 1, Appendix C
AC electric motor
P/N 314323660 (EF 1 and 2)
P/N 303158653 (SF 1 and 2)
Motor stator
P/N 314323660-2 (EF 1 and 2)
P/N 303158653-2 (SF 1 and 2)
Motor Rotor
P/N 314323660-3 (EF 1 and 2)
P/N 303158653-3 (SF 1 and 2)
Shaft
P/N 314323660-6 (EF 1 and 2)
P/N 303158653-6 (SF 1 and 2)
Ball bearings
P/N 416821-3K (EF 1 and 2, SF 1 and 2)
Woodruff key
P/N 314323660-21 (EF 1 and 2)
P/N 303158653-21 (SF 1 and 2)

See TM 55-1905-223-10 for HVAC systems
operations and equipment location.

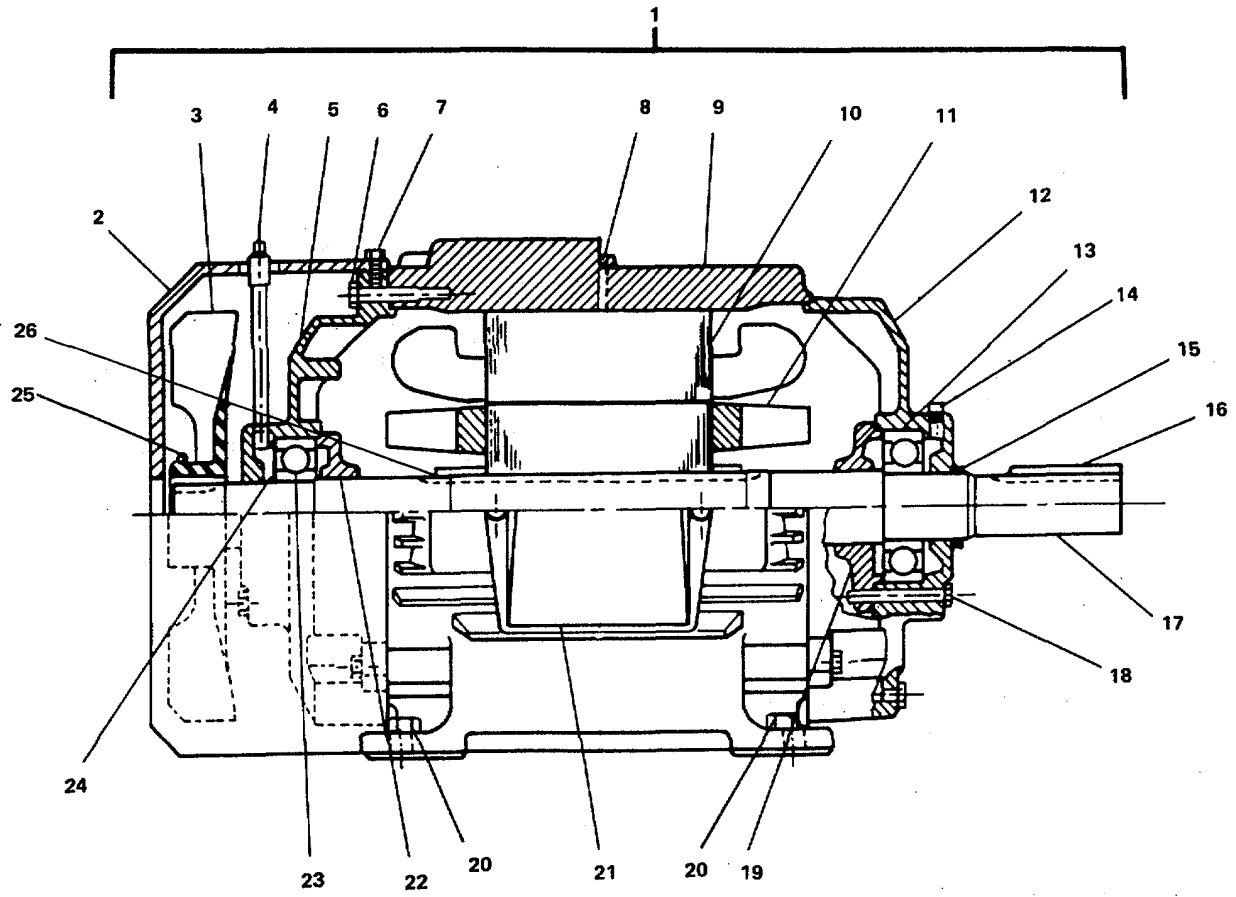

9926

Figure 4-2. AC Motor (EF #1 and #2: SF #1 and #2).

REMOVAL**WARNING**

Make sure electrical power is off to avoid personal injury.

- a. Tag and disconnect electrical wiring to motor jack box (21).
- b. Disconnect lubricating tubes from grease entries (4, 14).
- c. Remove mounting bolts (20).
- d. Remove the motor (1) from the fan unit.

DISASSEMBLY

- a. Remove Woodruff key (16) from shaft spline.
- b. Remove bolts (18) and remove back end bracket (12) and dirt deflector (15).
- c. Remove fan cover bolts (7) and remove fan cover (2). Remove grease entry tube (4), from bracket (5).
- d. Remove fan clamp (25) and remove outer fan (3) from motor shaft (17).
- e. Remove front end bracket bolts (6) and remove front end bracket (5). Remove washer (24).
- f. Remove the shaft (17) and bearings (13, 23) assembly from the motor.
- g. Make the following measurements and record:
 - (1) Measure the distance from back bearing (13) to the impeller end of the shaft (17).
 - (2) Measure the distance from front bearing (23) to the outer fan (3) end of shaft (17).
- h. Use a puller to remove the bearings (13, 23) and inner caps (19, 22) from shaft.
- i. Remove rotor (11) and spline key (26) from shaft with the puller from tool kit.
- j. Remove the machine screws (8) that mount the stator (10) to motor housing (9).
- k. Remove stator (10) from inside motor housing (9).

REPAIR

Repair consists of replacing motor bearings (13, 23), shaft (17), rotor (11), and stator (10).

ASSEMBLY

- a. Install stator (10) inside motor housing ,(9) with machine screws (8).
- b. Place key (26) in shaft spline. Align keyway in rotor and press rotor (11) onto shaft with a hydraulic press. Slide inner caps (19, 22) on shaft.
- c. Install new bearings (13, 23) on shaft (17).
 - (1) Make sure the collars are facing each other on the shaft.
 - (2) Refer to measurements recorded and bearings on shaft in same positions as old bearings that were removed.
- d. Install the shaft (17) and bearings (13, 23) assembly into the motor.
- e. Install washer (24) and front end bracket (5). Install bracket bolt (6).
- f. Install outer fan (3) on motor shaft (17) and install fan clamp (25).
- g. Align grease entry tube (4) and install fan cover (2). Install fan cover bolt (7).
- h. Install back end bracket (12) and dirt deflector (15). Install bolt (18).
- i. Position Woodruff key (16) in shaft spline.
- j. Install motor (1) onto fan unit.

REPLACEMENT

- a. Position motor (1) on fan unit and install to motor base (20) by connecting flat washer, lockwasher, and motor mounting lock nut with motor mounting screw and flat washer.
- b. Connect lubricating tubes to grease entries (4, 14).
- c. Connect electrical wiring in motor jack box (21).
- d. Install impeller, vane section, and outlet cone. Install ventilating fan unit (paragraph 4-11).
- e. Operational check:
 - (1) Turn electrical power ON.
 - (2) Start and run fan motor to check operation.
 - (3) Remove "Out of Service" tag from circuit.

4-13. Replace/Repair Fan, Ventilating (Supply Fans 1 and 2). (FIGURE 4-3)

This task covers:

- | | | |
|-------------|----------------|-----------|
| a. Removal | b. Disassembly | c. Repair |
| d. Assembly | e. Replacement | |

INITIAL SETUP:

Tools

Tool kit, general mechanic's
5180-00-699-5273
Tool kit, electrician's
5180-00-391-1087

Equipment Condition

Circuit breaker switched OFF,
power panel locked and tagged
"Out of Service - Do Not
Operate."

Materials/Parts

Warning tags, Item 1, Appendix C
Ventilating fan P/N 65-35-AVP3
Axial fan impeller P/N 656503500

See TM 55-1905-223-10 for HVAC systems
operations and equipment location.

REMOVAL

WARNING

Make sure electrical power is OFF to avoid personal injury.

- a. Turn electrical power OFF.
- b. Tag and disconnect electrical wiring to the fan.
- c. Remove mounting hardware (2, 3) and (13, 14) from each end of the fan (1). This will disconnect the fan from the bell inlet (23) and companion flange (12) at each end of the fan. The fan will be disconnected from deck when mounting hardware (13, 14) are removed.
- d. Remove the fan (1).

DISASSEMBLY

- a. With the fan unit removed, disconnect vane section (15) from fan housing (22) by removing mounting hardware (4, 10).
- b. Remove vibration isolator (11) from vane section (15).
- c. Remove hub screws (9) and remove hub cover (8).

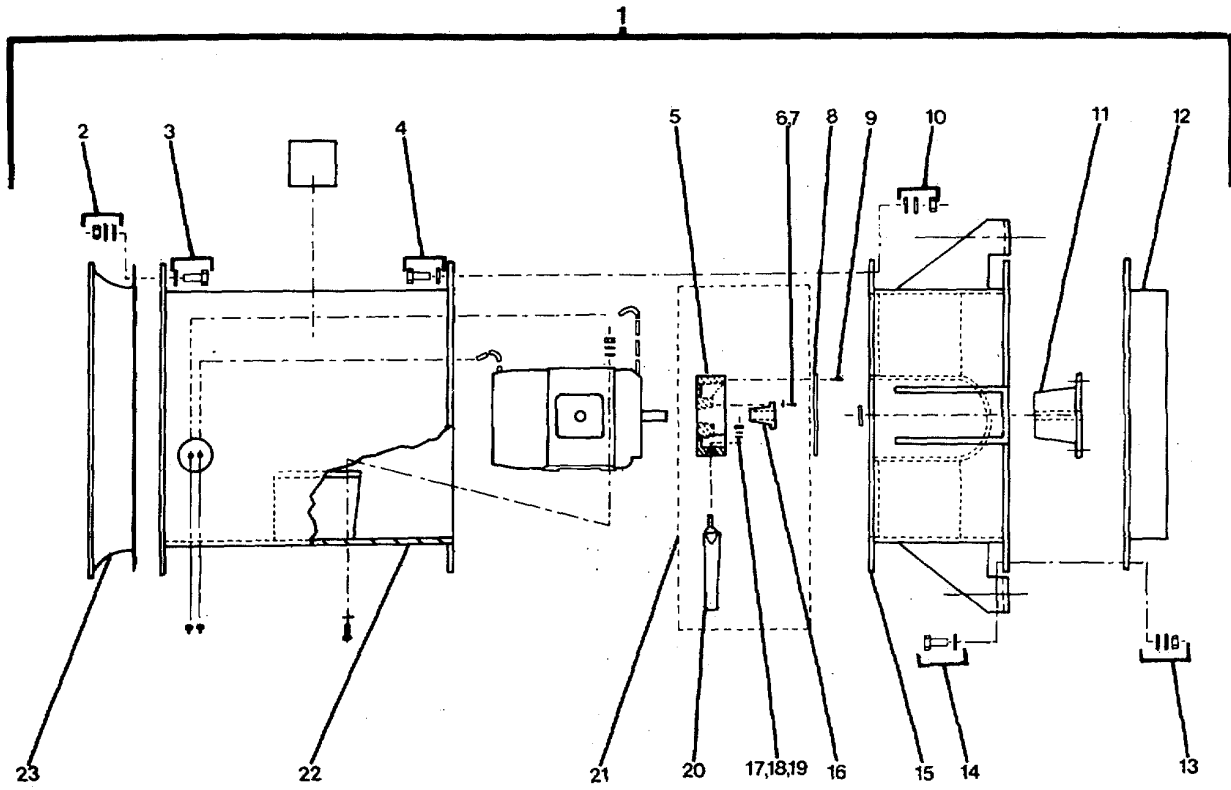

Figure 4-3 Ventilating Fan (Supply Fans 1 and 2 .

- d. Remove bushing retaining screws and washers (6, 7).
- e. Use puller to remove fan hub (5), bushing (16), and blades (20) from motor shaft as one assembly. Remove bushing (16) from fan hub (5).

NOTE

Fan hub, bushing, and blades are removed with the puller as one assembly. The tapered bushing holds the hub assembly in place when replaced and screws tightened. Blades are not disassembled from hub, since they are factory set for proper cubic feet per minute.

REPAIR

Repair consists of replacing the impeller (21).

ASSEMBLY

- a. Install bushing (16) in fan hub (5).
- b. Install fan hub (5), bushing (16) and blades (20) onto water shaft as one assembly.
- c. Install bushing retaining washers and screws (7, 6).
- d. Install hub cover (8) with hub screws (9).
- e. Install vibration isolator (11) in van section (15).
- f. Connect vane section (15) to fan housing (22) with mounting hardware (4, 10).

REPLACEMENT

- a. Position fan (1) and install mounting hardware (2, 3) and (13, 14) to connect fan to bell inlet (23), companion flange (12). The fan will be connected to deck when mounting hardware (15, 14) is installed.
- b. Connect electrical wiring to proper terminals on fan.
- c. Operational check:
 - (1) Turn electrical power ON.
 - (2) Start and run fan to check operation.
 - (3) Remove "Out of Service" tag from circuit.

4-14. Repair Air Conditioner Assembly (Air Conditioner 2; Accommodations)

This task covers: a. Adjustment b. Repair

INITIAL SETUP:
Tools

Tool kit, general mechanic's
5180-00-699-5273
Tool kit, electrician's
5180-00-391-1087
Tool kit, refrigeration and
air conditioning
5180-00-596-1474
Torque wrench
5120-01-092-3278

Equipment Condition

Except for cooling thermostat
replacement, system pumped
down and all tubing, lines, and
compressor purged residual
refrigerant charge (Item 10, Table
4-1).
Electrical power OFF and circuit
tagged "Out of Service."

Materials/Parts

Electrical tag, Item 1, Appendix C
Pressure switch P/N P28DA-1
Cooling thermostat P/N A19ABC-74
Hot gas valve P/N A9SE
Liquid line valve P/N ME25S270
Refrigeration ball valve P/N 592A-13ST
Refrigeration ball valve P/N 587A-14ST
Angle valve P/N 600A-4B
Pressure relief valve P/N 3014
Moisture indicator P/N 60-14S
R-22 refrigerant, Item 7, Appendix C

ADJUSTMENT

a. Adjust the oil pressure switch as follows:

- (1) The proper oil pressure cutout setting is 10 psi net oil pressure on the oil pressure switch (FIGURE 4-4). When a new pressure switch is installed the setting on the switch must be checked for proper setting. If the pointer (9) is not set (or pointing to) 10 psi on the setting indicator (10), the switch must be adjusted.

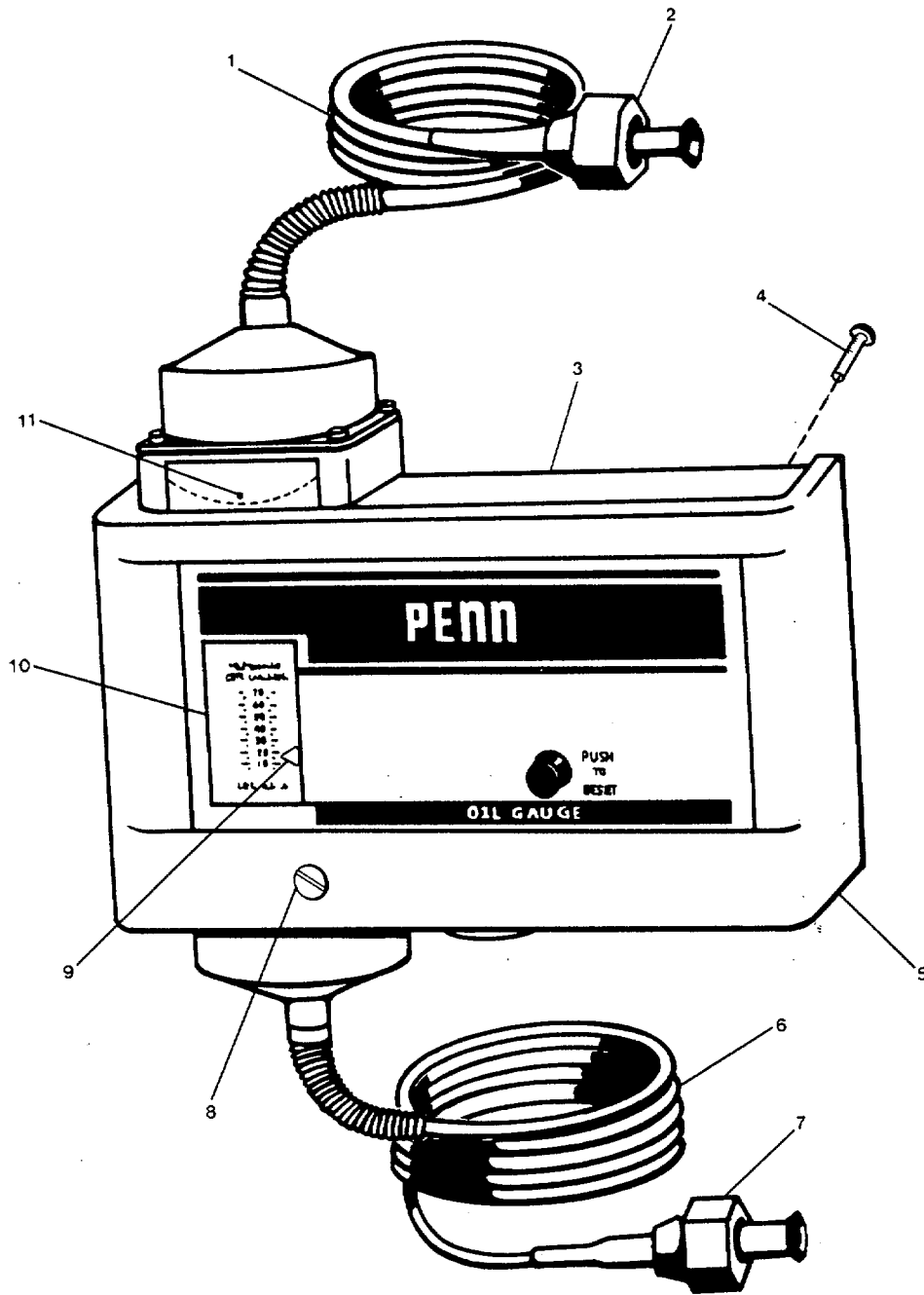

Figure 4-4. Oil Pressure Switch.

WARNING

Make sure electrical power is OFF during adjustment.

- (2) Remove the screw (8) and slide cover (5) from switch (3) for access to adjusting wheel (11).
 - (3) To raise the cutout setting pointer (9), turn the adjusting wheel (11) in a clockwise direction as viewed from the front of the switch. Turn the adjusting wheel counterclockwise to lower the cutout setting pointer.
 - (4) Adjust as required to set the pointer (9) to a reading of 10 psi on the setting indicator (10).
 - (5) Replace the cover (5) on the switch (3) with screw (8).
- b. Restore electrical power.

REPAIR**WARNING**

Make sure electrical power is OFF to avoid personal injury.

CAUTION

If the accommodations unit (A/C-2) main power breaker, or disconnect switch, has been turned OFF for over 4 hours, the HEAT/OFF/COOL manual switch on thermostat must remain OFF for a period of 5 hours after turning main power breaker, or disconnect, ON. This energizes the compressor crankcase heater and allows the oil time to reheat.

- a. Replace pressure switch (3, FIGURE 4-4) as follows:
- (1) Remove screw (8) and slide cover (5) from pressure switch (3) to access electrical wiring connections.
 - (2) Tag and disconnect external wiring to pressure switch (3).

WARNING

Make sure system has been pumped down or that all tubing, lines, and compressor have been purged of refrigerant charge before disconnecting oil line fittings (Item 10, Table 4-1).

- (3) Disconnect oil pressure line connection (2).
- (4) Disconnect compressor crankcase connection (7).
- (5) Remove the two screws (4) holding the pressure switch (3) to its mounting bracket.

- (6) Remove the pressure switch (3) with capillary tubing (1) and (6) attached.
- (7) Install new pressure switch to its mounting bracket with two screws (4).

CAUTION

Avoid sharp bends or kinks in capillary tubing (1) and (6).

- (8) Connect compressor crankcase connection (7).
 - (9) Connect oil pressure line connection (2).
 - (10) Coil excess tubing (1) and (6), but allow a small amount of slack to reduce noise.
 - (11) Replace cover (5) with screw (8).
 - (12) Open service valves and receiver outlet valve to allow refrigerant back into system.
 - (13) Restore electrical power and run air conditioner. Check for proper operation. Check refrigerant sight glass and add R-22 refrigerant as required (Item 6, Table 4-1).
 - (14) Remove "Out of Service" tag from circuit.
- b. Replace cooling thermostat (1, FIGURE 4-5) as follows:
- (1) Tag and disconnect electrical wiring to cooling thermostat.
 - (2) Remove screw (5) from clip (6) to disconnect bulb (4).
 - (3) Remove screw (3) and remove bracket (8).
 - (4) Remove two mounting screws (2) and remove cooling thermostat (1) with capillary (7) and bulb (4) attached.

CAUTION

Avoid sharp bends and kinks in capillary tubing (7).

- (5) Install new cooling thermostat (1) with two mounting screws (2).
- (6) Install bracket (8) with screw (3).
- (7) Mount bulb (4) with clip (6) and screw (5). Coil excess capillary tubing (7), but allow a small amount of slack to reduce noise.
- (8) Connect electrical wiring to proper terminals on thermostat.
- (9) Restore electrical power and operate the air conditioner. Check for proper operation.
- (10) Remove "Out of Service" tag from circuit.

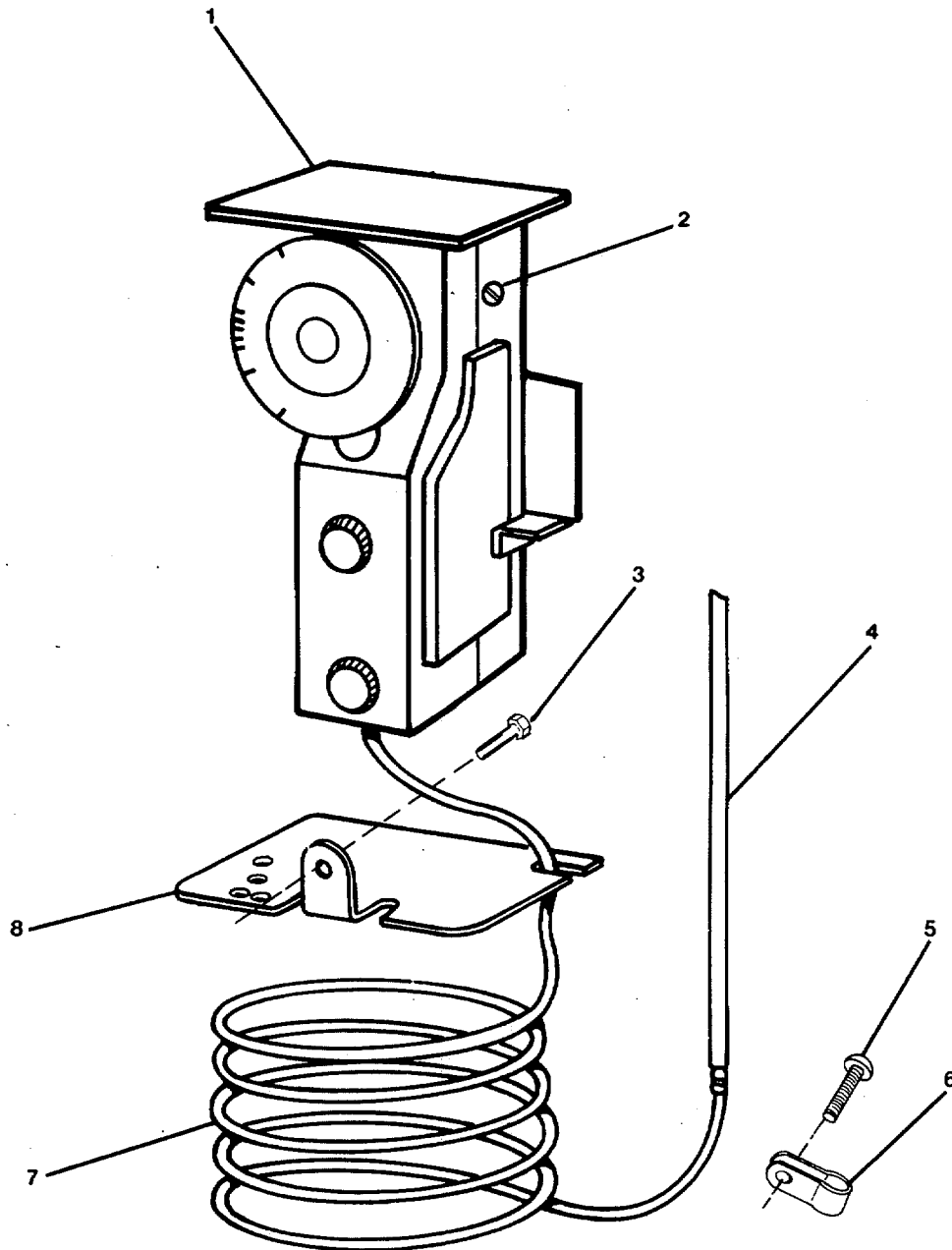

Figure 4-5. *Cooling Thermostat.*

- c. Replace hot gas valve (1, FIGURE 4-6) as follows:

WARNING

Make sure the refrigerant charge has been removed from system before opening line to replace valve.

- (1) Remove charge from system (paragraph 4-10).
- (2) Disconnect hot gas valve (1) at brazed connections (5) and (6) and remove valve from line.
- (3) Braze new hot gas valve (1) in line at connections (6) and (5).
- (4) Open service valves and receiver outlet valve to allow refrigerant back into system (paragraph 4-10).
- (5) Restore electrical power and run the air conditioner to check for proper operation. Check refrigerant sight glass and add R-22 refrigerant as required (paragraph 4-10).

NOTE

The hot gas valve (1) is factory pre-set to open at 53 psi.

- (6) Remove "Out of Service" tag from circuit.

- d. Replace liquid line valve in the liquid line portion of high side piping on A/C-2 (1, FIGURE 4-7) as follows:

WARNING

PRESSURIZED GAS HAZARD. Make sure the system has been pumped down and lines purged or residual refrigerant charge. (Item 10, Table 4-1).

- (1) Tag and disconnect electrical wiring to liquid line valve (1) in the liquid line portion of high side piping on A/C-2.
- (2) Disconnect valve at fitting (3) and at brazed connections (2) and (4) and remove valve (1).
- (3) Braze new liquid line valve (1) at connections (2) and (4). Connect fitting (3).
- (4) Connect electrical wiring to liquid line valve (1) terminals.
- (5) Evacuate and re-charge system with R-22 (paragraph 4-10).
- (6) Restore electrical power and run air conditioner to check for operation. Check refrigerant sight glass and add R-22 refrigerant as required (paragraph 4-10).
- (7) Remove "Out of Service" tag from circuit.

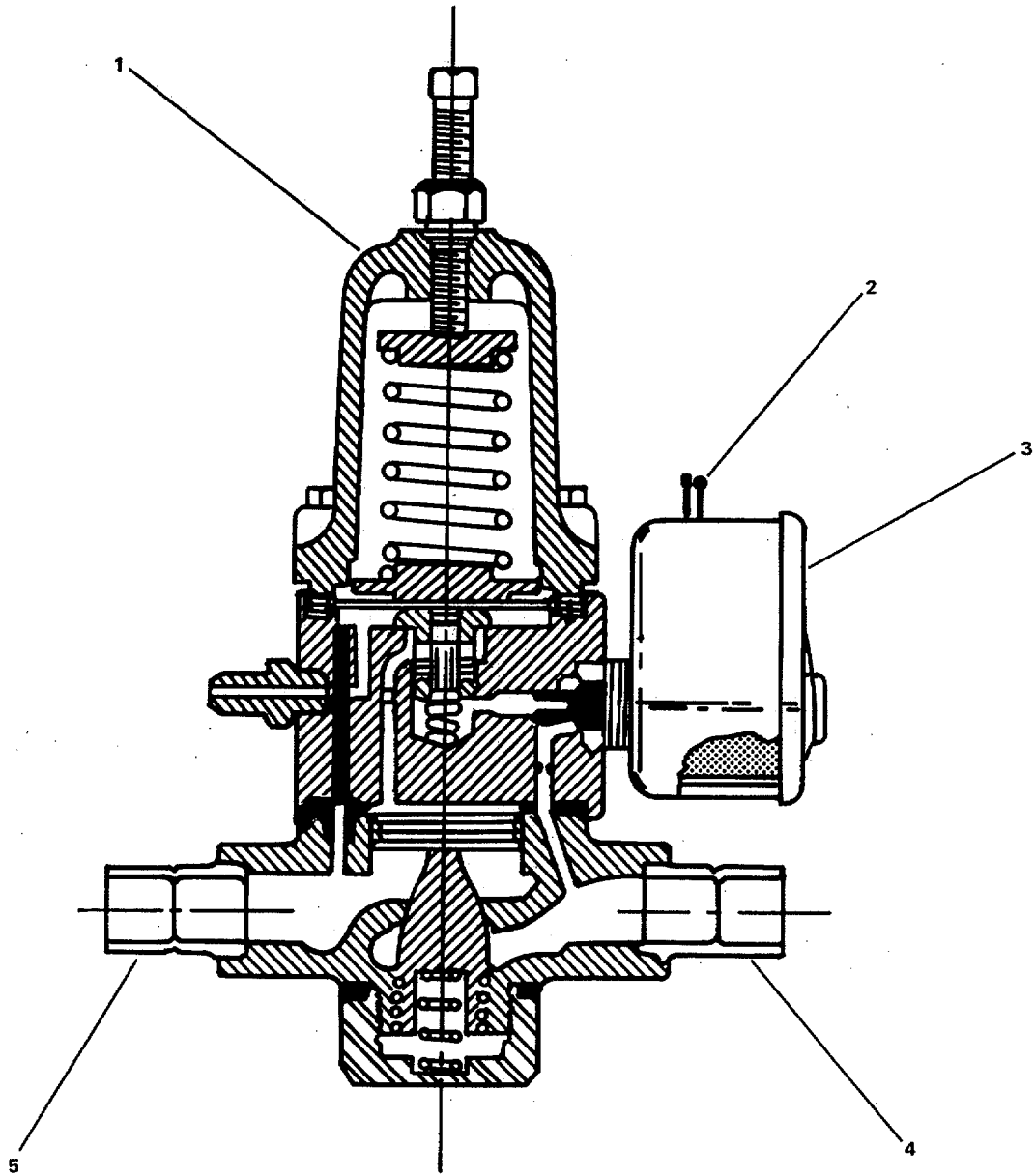

Figure 4-6. *Hot Gas Valve.*

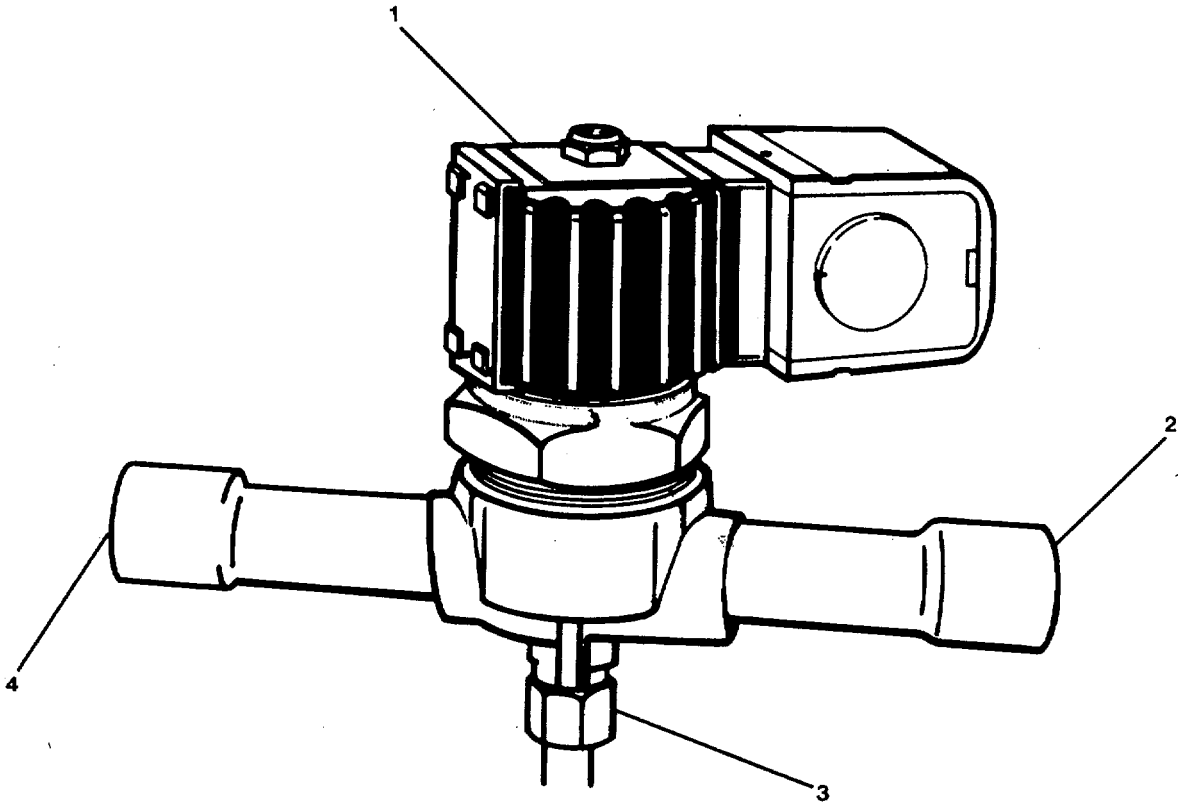

Figure 4-7. Liquid Line Valve (High Pressure Solenoid).

- e. Replace refrigeration ball valves (1, 5, FIGURE 4-8) as follows:

WARNING

PRESSURIZED GAS HAZARD. Make sure the system has been pumped down and lines purged of residual refrigeration charge (Item 10, Table 4-1).

- (1) Remove ball valves.
 - (a) Disconnect ball valve (1) at brazed connections (3) and (4).
 - (b) Disconnect ball valve (5) at brazed connections (8) and (9).
 - (c) Remove ball valve (1) or (5) from refrigerant line.
 - (2) Replace ball valves.
 - (a) Position new refrigeration ball valve (1) or (5) in refrigerant line.
 - (b) Braze new ball valve (1) at connections (3) and (4).
 - (c) Braze new ball valve (5) at connections (8) and (9).--
 - (3) Make sure all ball valves are in OPEN position.
 - (a) Turn visual indicator stem (2) on ball valve (1) to the OPEN position.
 - (b) The seal cap (7) must be removed from ball valve (5) for access to valve stem (6). Remove cap and turn valve stem to OPEN position. Install seal cap (7).
 - (4) Open service valves and receiver outlet valve to allow refrigerant back into the system.
 - (5) Restore electrical power and run air conditioner to check for proper operation. Check refrigerant sight glass and add R-22 refrigerant as required (paragraph 4-9).
 - (6) Remove "Out of Service" tag from circuit.
- f. Replace angle valve (5, FIGURE 4-9) as follows:

WARNING

PRESSURIZED GAS HAZARD. Make sure the system has been pumped down and lines purged of residual refrigerant charge (Item 10, Table 4-1).

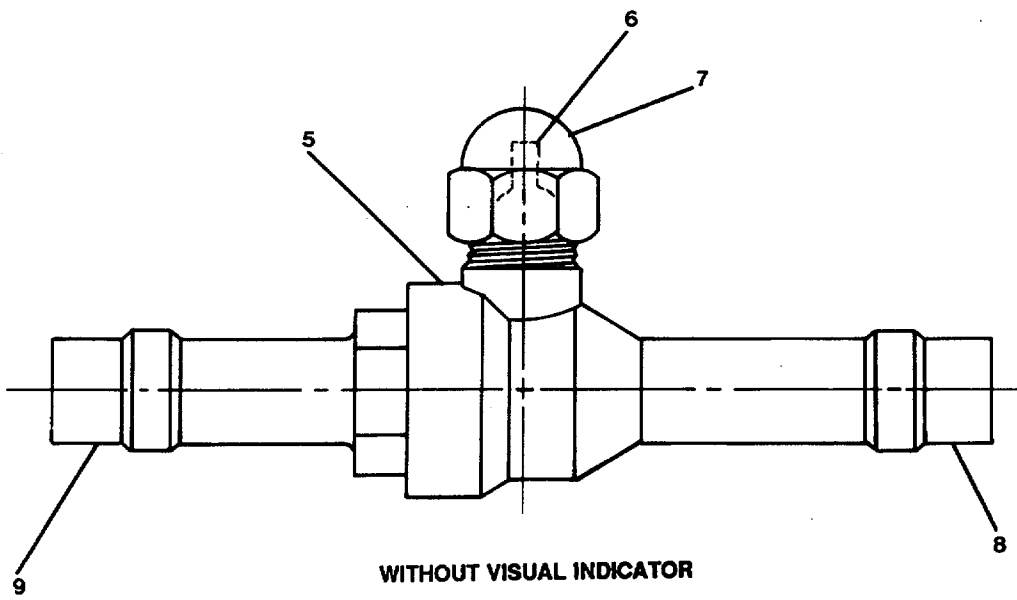
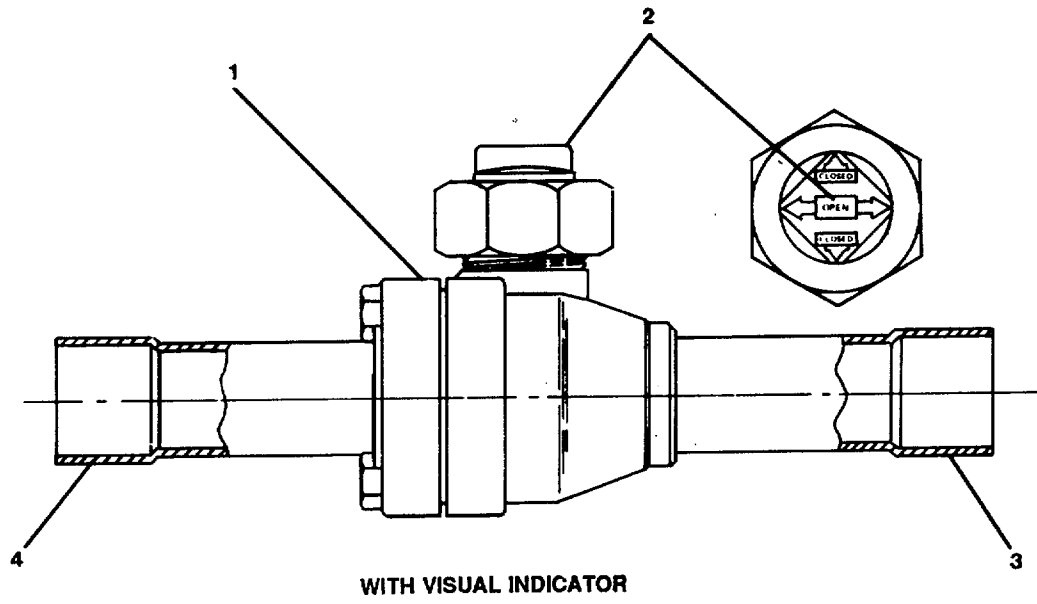

Figure 4-8. *Refrigeration Ball Valves.*

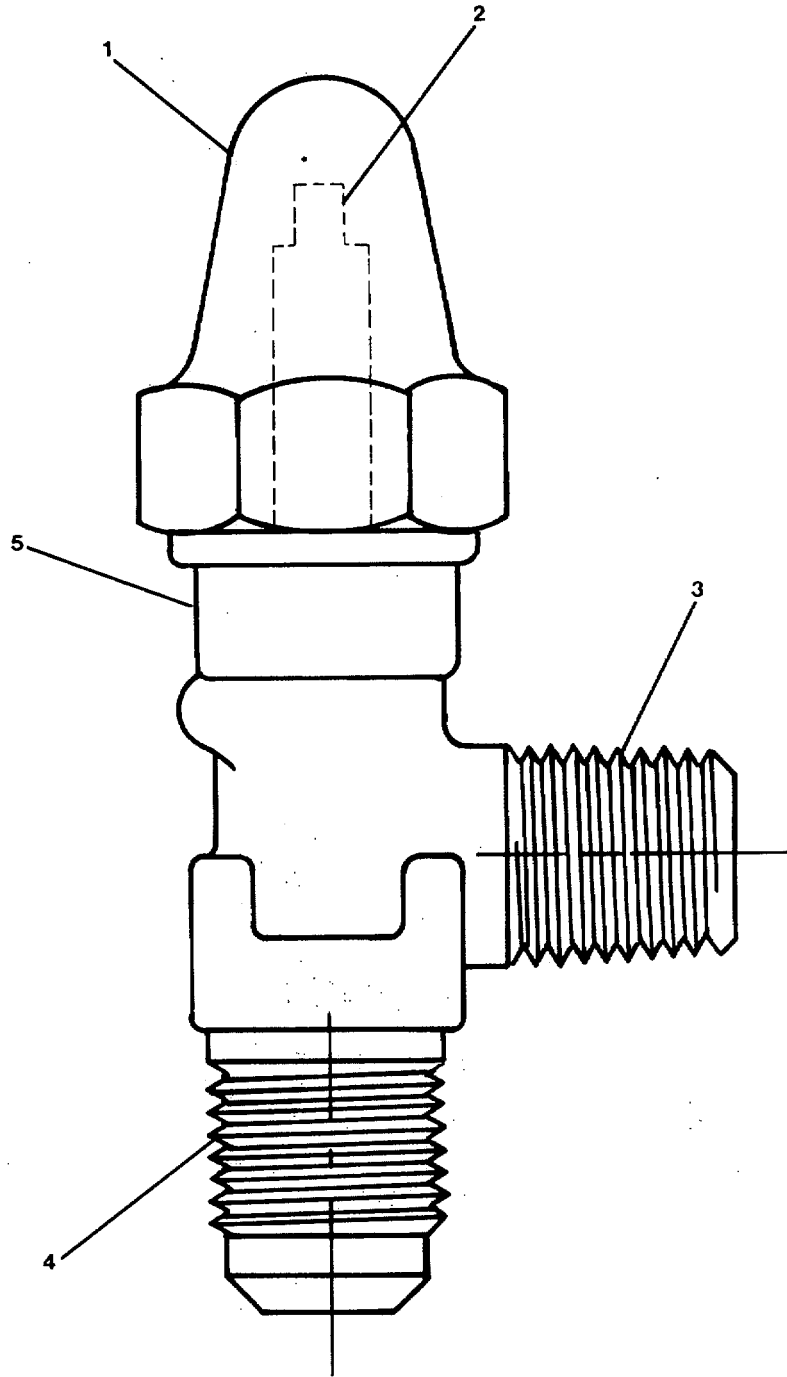

Figure 4-9. Angle Valve.

- (1) Disconnect angle valve (5) at connections (3) and (4) and remove valve (5) from high side refrigerant line at receiver outlet.
 - (2) Install new angle valve (5) at connections (3) and (4).
 - (3) Remove cap (1) and make sure valve is open by turning valve stem (2) fully counterclockwise. Install cap (1).
 - (4) Open service valves and receiver outlet valve to allow refrigerant back into the system.
 - (5) Restore electrical power and run air conditioners to check for proper operation. Check refrigerant sight glass and add R-22 refrigerant as required (paragraph 4-10).
 - (6) Remove "Out of Service" tag from circuit.
- g. Replace pressure relief valve on receiver (1, FIGURE 4-10) as follows:

WARNING

PRESSURIZED GAS HAZARD. Refrigerant charge must be completely removed from system before removing pressure relief valve from receiver.

- (1) Remove any refrigerant left in system.
 - (2) Remove pressure relief valve (1) by turning hex fitting (2) at base of valve counterclockwise.
 - (3) Install new pressure relief valve (1) by turning hex fitting (2) clockwise until snug.
 - (4) Evacuate and charge system with R-22 refrigerant (paragraph 4-10).
 - (5) Restore electrical power and run air conditioned to check for proper operation.
 - (6) Remove "Out of Service" tag from circuit.
- h. Replace moisture indicator (1, FIGURE 4-11) as follows:

WARNING

PRESSURIZED GAS HAZARD. Make sure the system has been pumped down and lines purged of residual refrigerant charge (Item 10, Table 4-1).

- (1) Remove moisture indicator (1, FIGURE 4-11) by disconnecting fittings (2) and (3).
- (2) Install new moisture indicator (1) by connecting fittings (3) and (2).

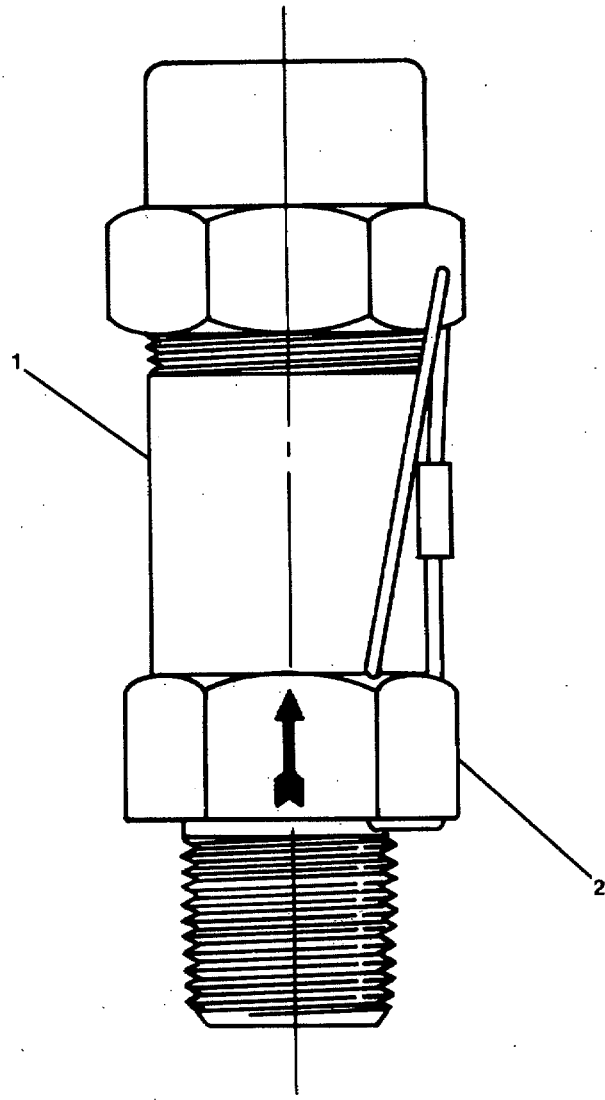

Figure 4-10. Pressure Relief Valve.

- (3) Open service valves and receiver outlet valve to allow refrigerant back into system.
- (4) Restore electrical power and run air conditioner to check for proper operation. Check refrigerant sight glass and add R-22 refrigerant as required (paragraph 4-10).
- (5) Remove "Out of Service" tag from circuit.

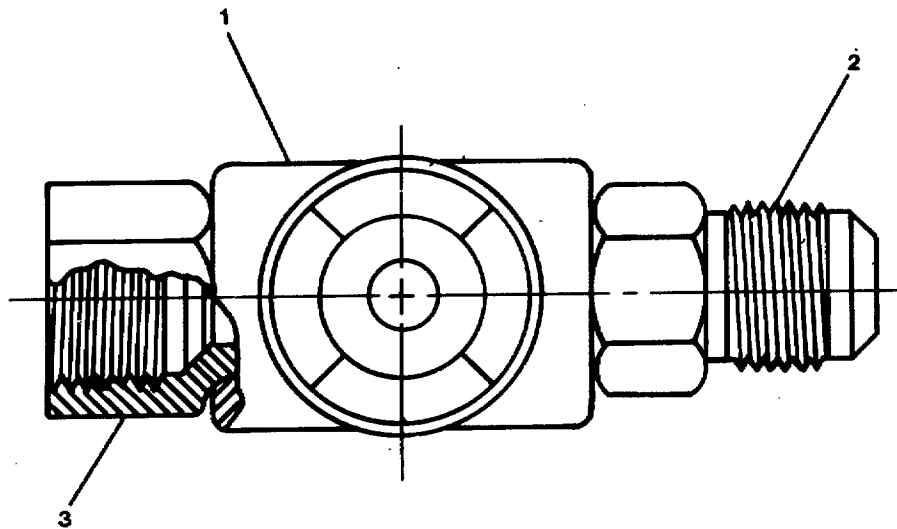

Figure 4-11. Moisture Indicator.

4-15. Repair Motor, Electric. (FIGURE 4-12)

This task covers: a. Removal b. Repair c. Replacement.

INITIAL SETUP:Tools

Tool kit, general mechanic's
5180-00-699-5273
Tool kit, electrician's
5180-00-391-1087

Equipment Condition

Belt guard, V-belt, and motor
pulley removed (para. 2-34).

Electrical power OFF and circuit
tagged "Out of Service."

Materials/Parts

Electrical tag, Item 1, Appendix C
Electric motor P/N COG 4B

REMOVAL**WARNING**

Make sure electrical power is OFF to avoid personal injury.

- a. Tag and disconnect electrical wiring from terminal box (2, FIGURE 4-11).
- b. Remove four mounting bolts (3) and remove electric motor (1).

REPAIR

Repair consists of replacing the electric motor (REMOVAL and REPLACEMENT steps of this procedure).

REPLACEMENT

- a. Install new electric motor (1) with four mounting bolts (3).
- b. Connect electrical wiring to proper terminals in terminal box (2).
- c. Install motor pulley, V-belt, and belt guard (paragraph 2-33).
- d. Restore electrical power and run air conditioner to check for proper operation.
- e. Remove "Out of Service" tag from circuit.

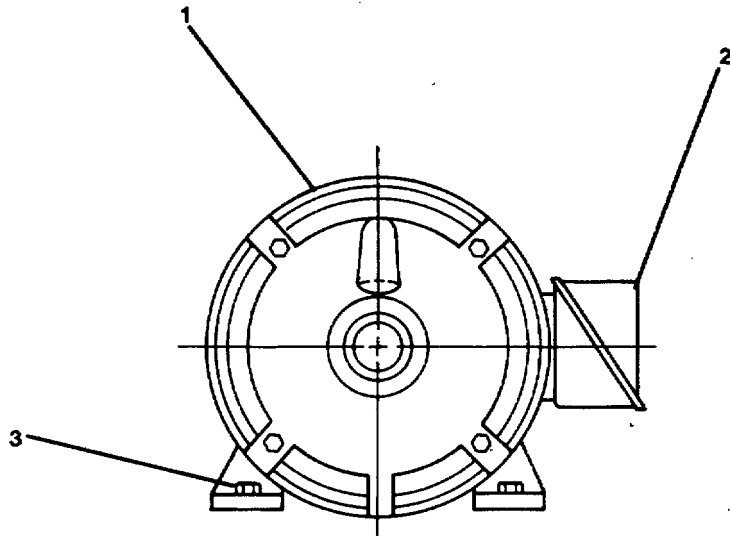

Figure 4-12. Electric Motor.

4-16. Replace/Repair Blower. (FIGURE 4-13)

This task covers: **a. Removal** **b. Disassembly** **c. Repair.** **d. Assembly**
 e. Replacement

INITIAL SETUP :Tools

Tool kit, general mechanic's
5180-00-699-5273

Materials/Parts

Blower P/N LSL-106C
Electrical tag, Item 1, Appendix C

Equipment Condition

Belt guard and V-belt removed,
(para. 2-39).
Electric motor removed (para. 4-15).

Electrical power OFF and tagged
"Out of Service."

REMOVAL**WARNING**

Make sure electrical power is OFF to avoid personal injury.

- a. Disconnect ducting from blower outlet.
- b. Remove screw (1) from each corner of blower section cover (2).
- c. Remove the capscrews (15) and washers (14) that attach the blower section (3) to coil section of air conditioner assembly.
- d. Remove mounting screw (7) from each bottom corner of blower frame (3).
- e. Remove blower section (3) from air conditioner assembly.

DISASSEMBLY

- a. Remove the standing tube with grease fitting (11) from the flange bearing (9).
- b. Remove the two mounting screws (10) from the flange bearing (9).
- c. Loosen the impeller setscrew (4) from inside the fan housing (5). Slide the drive shaft (12) with flange bearing (9) from the blower section (3). Remove the flange bearing from the drive shaft.

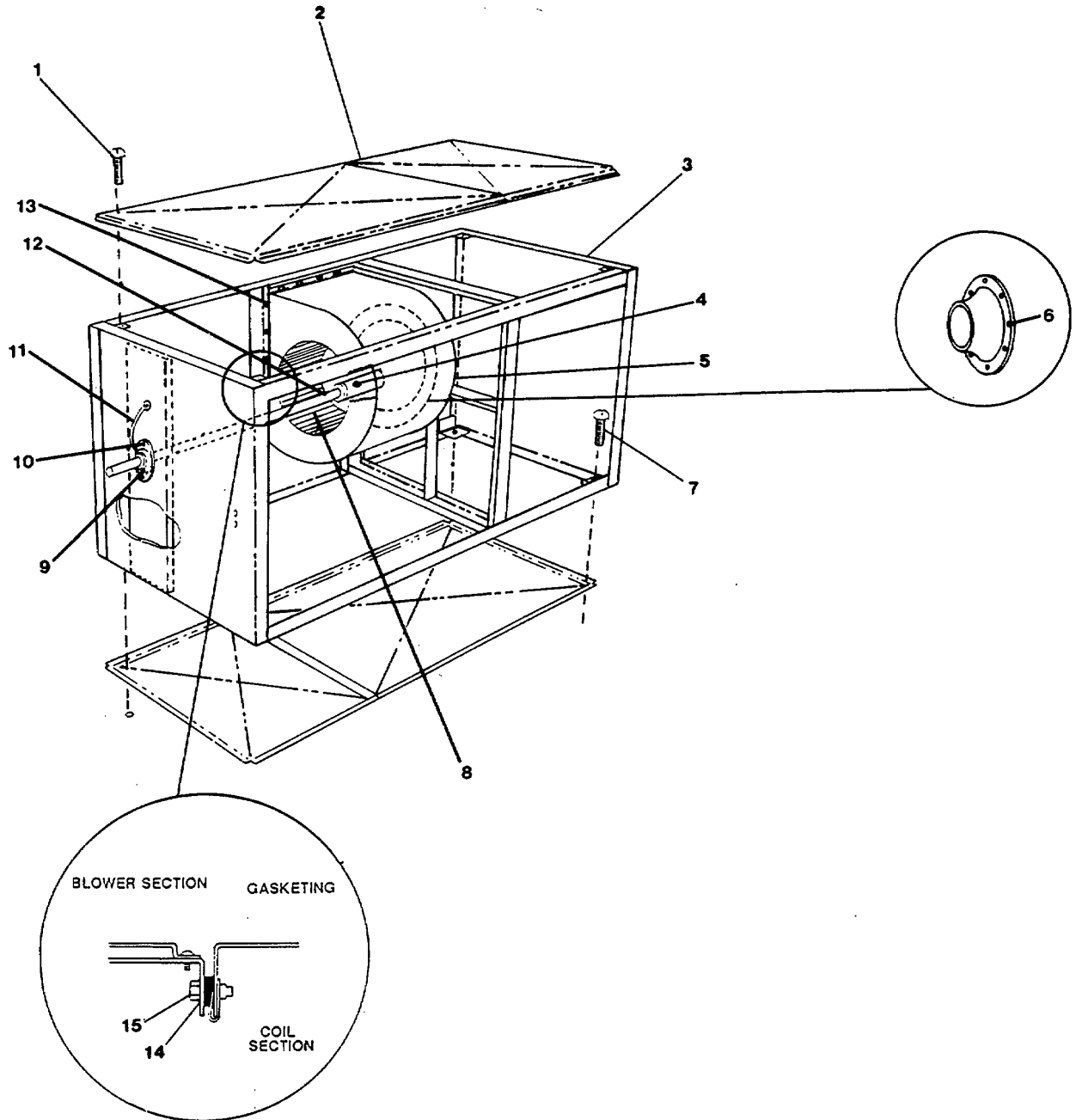

Figure 4-13. Blower.

- d. Remove the screws (13) around the blower outlet and remove the fan housing (5) from the blower section.
- e. Remove the screws from the housing cone (6) and remove the cone from the housing (5).
- f. Lift the impeller (8) free of the fan housing (5).

REPAIR

Repair consists of replacing unserviceable items or replacing the blower assembly.

ASSEMBLY

- a. Place the impeller (8) inside the fan housing (5) and install housing cone (6).
- b. Connect the fan housing (5) to the blower section (3) with mounting screws (13).

NOTE

Two soldiers required for following task.

- c. Slide the drive shaft (12) into the blower section (3). Position the impeller (8) from inside the fan housing (5) to align with drive shaft. Slide drive shaft into impeller. Do not tighten setscrew (4) at this time.
- d. Install the flange bearing (9) onto drive shaft end. Install flange bearing mounting screws (10).
- e. Make sure impeller (8) is free to turn in fan housing, and tighten setscrew (4) until snug.
- f. Install standing tube with grease fitting (11) to flange bearing (9).

REPLACEMENT

NOTE

Ensure that gasketing is in place on coil section when installing blower.

- a. Mount blower (3) to air conditioner assembly with screws (4).
- b. Attach blower (3) to coil section with capscrews (15) and washers (14).
- c. Install blower section cover (2) with screws (1).
- d. Connect ducting to blower outlet (7).

- e. Install electric motor (paragraph 4-15).
- f. Install V-belt and guard (paragraph 2-34).
- g. Restore electrical power and run air conditioner to check for proper operation.
- h. Remove "Out of Service" tag from circuit.

4-17. Replace Liquid Refrigerant Receiver. (FIGURE 4-14)

This task covers:**a. Removal****b. Replacement**

INITIAL SETUP:**Tools**

Tool kit, general mechanic's,
5180-00-699-5273
Tool kit, refrigeration and
air conditioning,
5180-00-596-1474
Torque wrench
5120-01-242-3264 (0-50 ft-lb)

Materials/Parts

Liquid refrigerant receiver
P/N 1087-4
Crocus cloth (fine),
Item 5, Appendix C
Warning tags, Item 1, Appendix C

Equipment Condition

All R-22 refrigerant removed from
system (4-9).

WARNING

Turn primary breaker OFF and tag
circuit "Out of Service."

REMOVAL**WARNING**

Make sure all refrigerant has been removed from system before disconnecting receiver.

- a. Disconnect the brazed outlet connections (2) and (5) on the receiver (1).
- b. Disconnect the brazed inlet connection (4).
- c. Remove the pressure relief valve from threaded connection (3).
- d. Remove the mounting bolts (6), nuts (8), and washers (7) from the mounting foot (9) at each end of the receiver.
- e. Lift the receiver (1) from the air conditioner assembly.

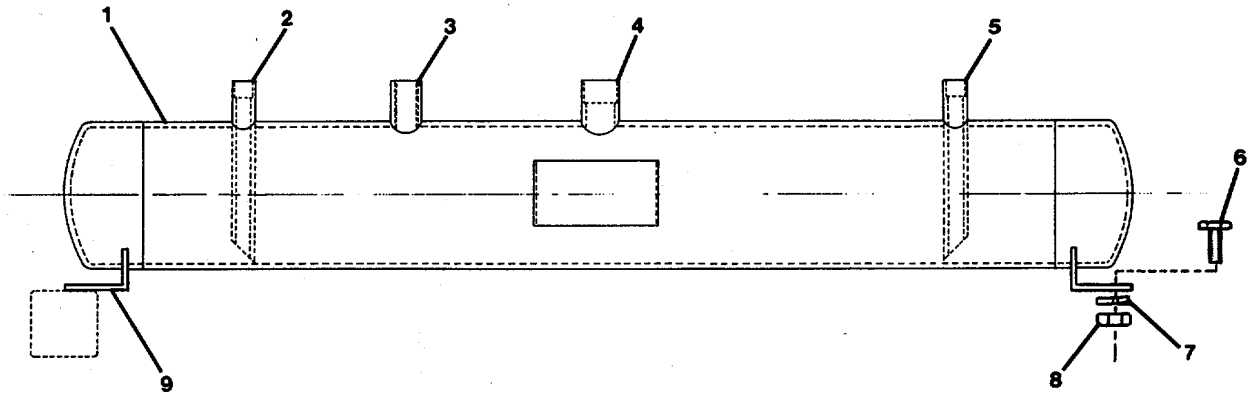

Figure 4-14 . Liquid Refrigerant Receiver .

REPLACEMENT

- a. Position the receiver (1) on the air conditioner assembly and install mounting bolts (6), washers (7), and nuts (8) in the mounting foot (9) on each end of the receiver. Torque bolts to 28 ft-lb.
- b. Make sure a pressure relief valve is installed in threaded connection (3). A new receiver should already have a relief valve installed. If not, refer to paragraph 4-14 to install new relief valve.

CAUTION

Do not let excess brazing material or other debris enter the openings in the receiver.

- c. Clean all connections and piping ends with fine crocus cloth before brazing.

WARNING

Avoid contact with heated connections in order to prevent burn injury.

- d. Braze inlet piping to connection (4).
- e. Braze outlet piping to connections (2) and (5).
- f. Allow brazed connections time to cool to ambient temperature before charging the system.
- g. Evacuate the system and charge with new R-22 refrigerant (4-10).
- h. Restore power, start and run the air conditioner, and check operation.
- i. Remove "Out of Service" tag from circuit.

4-18. Repair Water Cooled Refrigerating Condenser. (FIGURE 4-15)

This task covers:**a. Removal****b. Repair****c. Replacement**

INITIAL SETUP:Tools

Tool kit, general mechanic's,
5180-00-699-5273

Tool kit, refrigeration and
air conditioning,
5180-00-596-1474

Equipment Condition

Water-cooled refrigerating condenser
removed.

Materials/Parts

Wiping rags, Item 6, Appendix C
Gaskets P/N R0002-14

REMOVAL

- a. Remove the eight nuts (2), washers (4), and steel strap and slug (5), and bolts (3) at both ends of the condenser (1), top and bottom.
- b. Remove the steel legs (11) from the bottom bolts (3).
- c. Remove 36 bronze bolts (7) and 36 brass insert nuts (6) from each end of the condenser (1).
- d. Remove the Delrin head (8) from each end of the condenser.
- e. Remove gasket (9) and flange plate (10) from each end of the condenser.
- f. Remove the 27 shell (13) and tube (12) assemblies from support straps (14).

REPAIR

Repair is by replacement of disassembled parts.

REPLACEMENT

- a. Insert the 27 shell (13) and tube (12) assemblies into support straps (14).

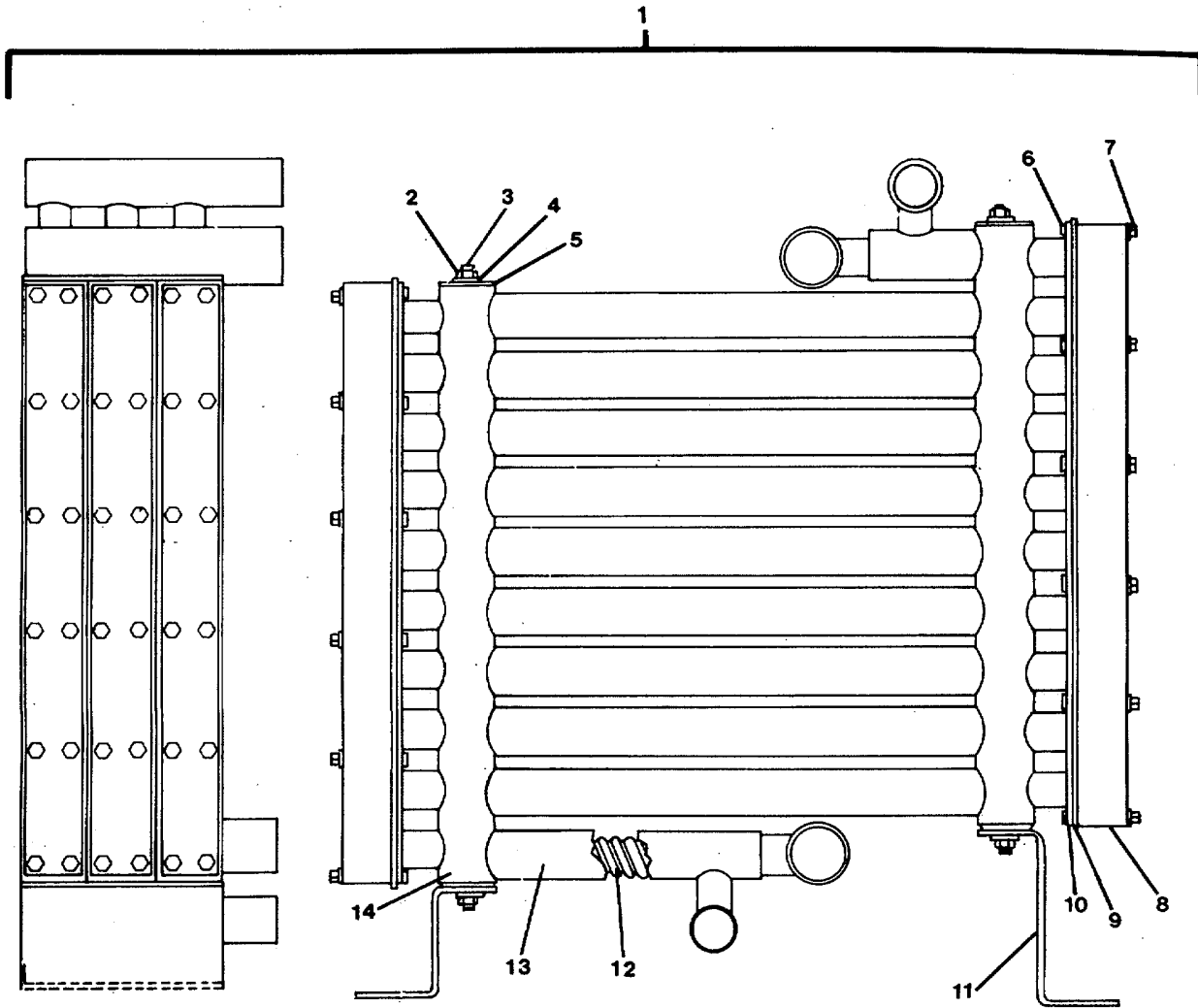

Figure 4-15. Water Cooled Refrigerating Condenser .

- b. Install flange plate (10), gasket (9), and Delrin head (8) to each end of condenser with bronze bolts (7) and brass insert nuts (6). Tighten bolts alternately until snug.
- c. Install steel strap and slug (5), bolts (3), washers (4) and nuts (2) to the top corners of the condenser (1).
- d. Install the bolts (3), support leg (11), washers (4) and nuts (2) to the bottom corners of the condenser. Tighten nuts (2) until snug.
- e. Install the water cooled refrigerating condenser (1) on the air conditioner assembly.

4-19. Replace/Repair Compressor, Refrigeration.

This task covers:

a. Removal

b. Repair

c. Replacement

INITIAL SETUP:

Tools

Tool kit, general mechanic's,
5180-00-699-5273
Tool kit, electrician's,
5180-00-391-1087
Tool kit, refrigeration and
air conditioning,
5180-00-596-1474
Torque wrench,
5120-01-092-3278
Torque wrench,
5120-01-125-5190
Portable vacuum pump unit
4310-00-289-5967

Equipment Condition

Electrical power OFF and circuit
tagged "Out of Service."

Materials/Parts

Electrical tags, Item 1, Appendix C
Refrigeration compressor P/N 06D()537
Thermostat P/N 06DA-660-055
Gasket P/N 6-D-40-1061
Package suction valve
P/N 06 EA- 660090
Gasket P/N 6-D-68-1131
Package discharge valve
P/N 06 DA660062
Discharge gasket P/N 6-D-40-1131
Gasket set P/N 6-D-43-172
Gasket P/N 6-D-68-1053
Gasket P/N 6-D-75-2672
Gasket P/N AU-51YA-011
Assembly relief valve P/N 6-D-23-522
Gasket P/N 6-F-25-1013
Gasket P/N 6-D-68-1043
Safety relief valve P/N 6-D-40-162
Pump and bearing assembly head
P/N 6-D-68-952
Compressor crankshaft P/N 6-D-75-722
Rotor drive key P/N AW-01DA-096
Connecting rod and cap assembly
P/N 06DA660042

Materials/Parts (cont'd)

Compressor piston P/N 6-D-75-181
Piston ring P/N AU-50CP-245
Piston ring P/N AU-50CP-355
Valve plate package P/N 6-D-75-253
Valve plate assembly P/N 6-D-75-163
Check valve piston P/N 06DA-502-322
Check valve spring P/N 6-D-75-2081
Compressor oil, Item 8, Appendix C
R-22 refrigerant, Item 7, Appendix C
Mineral spirits, Item 9, Appendix C

REMOVAL**WARNING**

Make sure electrical power is OFF to avoid personal injury.

PRESSURIZED GAS HAZARD. Make sure the compressor has been isolated from system and refrigerant removed before opening.

CAUTION

If the Accommodations Unit's (A/C-2) main power breaker, or disconnect switch, has been turned OFF for over 4 hours, the unit's HEAT/OFF/COOL manual switch on thermostat must remain OFF for a period of 5 hours after turning main power breaker, or disconnect, ON. This energizes the compressor crankcase heater and allows the oil time to re-heat.

a. Isolate and remove refrigerant from compressor as follows:

- (1) Connect a portable gauge manifold from the refrigeration tool kit to the compressor as follows (refer to FIGURES 4-16, 4-17, and 4-18):

NOTE

If the charge has not been lost due to a leak or break in line, this procedure will save the refrigerant remaining in the system.

- (a) Connect the combination gauge hose (7, FIGURE 4-16) to the gauge port connection on the compressor suction valve (7, FIGURE 4-17).

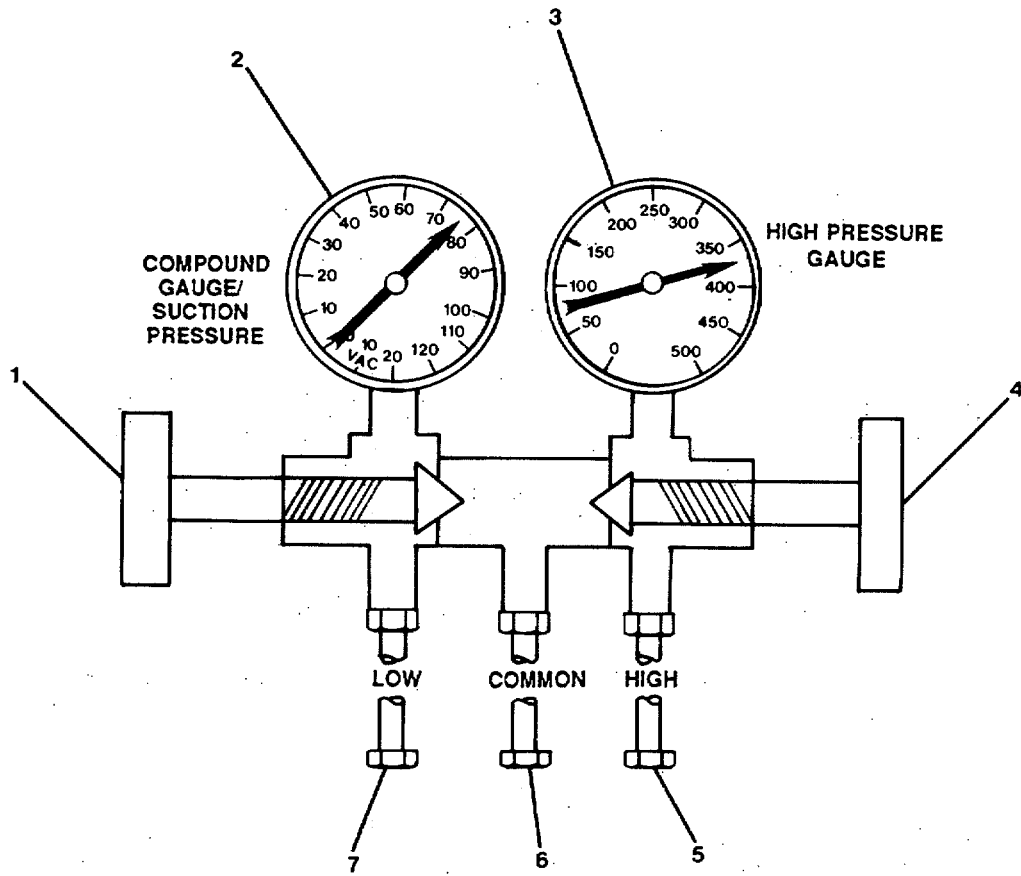

Figure 4-16. Portable Gauge Manifold.

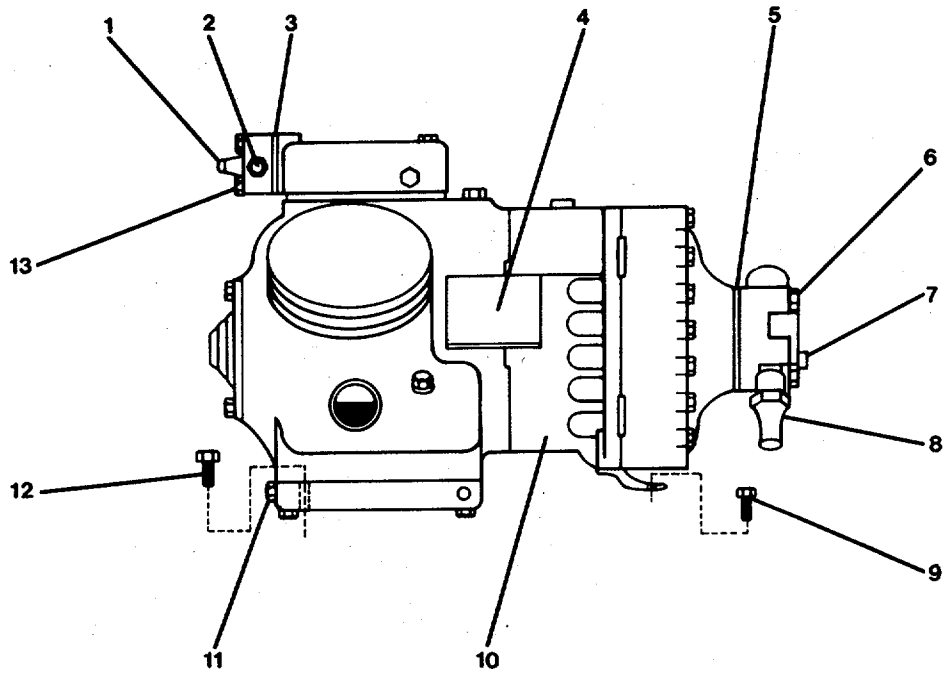

FIGURE 4-17. Refrigeration Compressor.

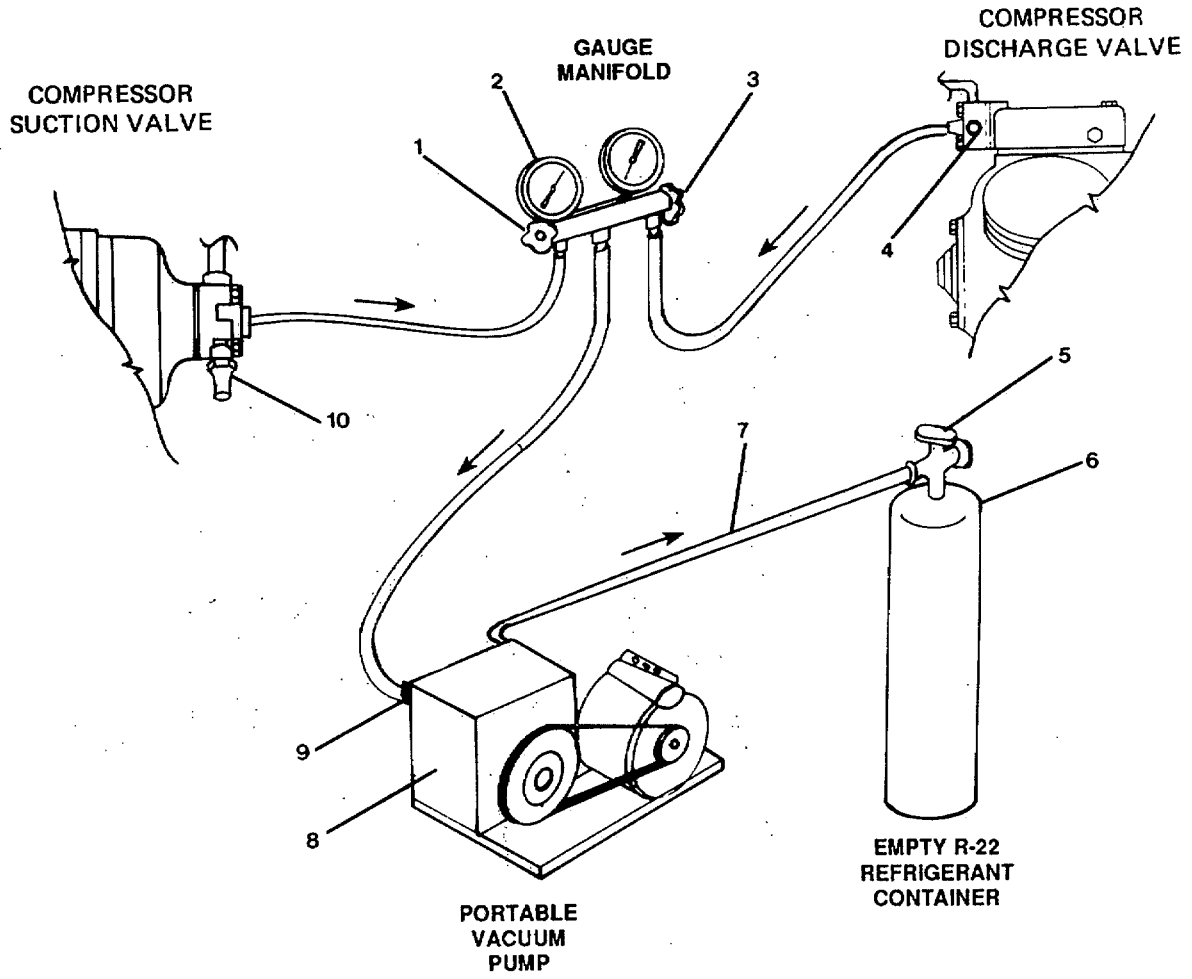

Figure 4-18. *Removing Refrigerant Charge From Compressor.*

- (b) Connect the high pressure gauge (3, FIGURE 4-16) hose (5) to the gauge port connection on the compressor discharge valve (1, FIGURE 4-17).
 - (c) Connect the common hose (6, FIGURE 4-16) to the suction connection (9, FIGURE 4-18) on a portable vacuum pump (8).
 - (d) Connect the discharge line (7) of the vacuum pump to an empty R-22 refrigerant container (6). Make sure hand-wheel, gauge port, valves (1, 3) are closed by turning fully clockwise.
- (2) Remove cap (10) from suction valve and cap (4) from discharge valve for access to valve stems.
 - (3) Close both suction and discharge valves by turning valve stems fully clockwise. This will isolate the compressor from the rest of the system.
 - (4) Slowly open the handwheel gauge port valves (1, 3) counterclockwise 1/2 to 1 turn. This will allow the refrigerant to escape from the compressor and through the gauge manifold.
 - (5) Open the valve (5) on the empty container (6) by turning counterclockwise.
 - (6) Start and run the portable vacuum pump (8).
 - (7) While the vacuum pump is running, watch the pressure on the combination gauge (2). When pressure has dropped to 1 or 2 psig on gauge (2), close hand wheel gauge port valves (1, 3) and stop the vacuum pump. This will leave a slight positive charge on the compressor.
 - (8) If gauge pressure increases rapidly, repeat steps a.(5) through (8) above until 1 or 2 psig is maintained on combination gauge (2).
 - (9) Close valve (5) on container (6) by turning fully clockwise.

WARNING

Purge hoses before disconnecting. Residual freon in lines can cause personal injury.

- (10) Disconnect all manifold gauge hoses (5, 6, 7, FIGURE 4-16).

WARNING

Purge hoses before disconnecting. Residual freon in lines can cause personal injury.

- (11) Disconnect vacuum pump discharge line (7, FIGURE 4-18) from container (6).

b. Disconnect suction valve (7, FIGURE 4-17) from compressor (10):

- (1) Remove four capscrews (6). The valve body will remain attached to refrigerant piping.
- (2) Remove gasket (5) and discard.

NOTE

New capscrews (6) and gasket (5) will be furnished with replacement -compressor.

c. Disconnect discharge valve (1) from compressor (10):

- (1) Remove two capscrews (13). The valve body will remain attached to refrigerant piping.
- (2) Remove gasket (3) and discard.

NOTE

New capscrews (13) and-gasket (3) will be furnished with replacement compressor.

d. Tag and disconnect all electrical wiring from terminal box (4).

e. Disconnect oil pressure switch from compressor (paragraph 4-14).

f. Remove two mounting bolts (9) and two mounting bolts (12).

g. Remove compressor (10) from air conditioner assembly.

h. Remove drain plug (11) from compressor and drain oil. Install plug (11) after draining oil. Discard oil.

REPAIR

WARNING

Make sure electrical power is OFF to avoid personal injury.

PRESSURIZED GAS HAZARD. Make sure compressor has been isolated from the system and refrigerant charge removed before replacing components.

a. Remove refrigerant charge from compressor:

NOTE

The system cannot be pumped down when discharge and suction service valves are being replaced with the compressor.

- (1) When possible, pump down the system to remove refrigerant charge from compressor (Item 10, Table 4-1).
 - (2) When defective components make it impossible to pump down the system, remove refrigerant charge using the method given in (paragraph 4-10).
 - (3) When replacing compressor suction and/or discharge service valve(s) (16 and 1, FIGURE 4-19) the valves must also be isolated from the rest of the system. Evacuate and recharge with R-22 refrigerant when discharge service valve is being replaced (paragraph 4-10).
- b. Replace thermostat (25, FIGURE 4-19) and/or terminal gasket (28).
- (1) Remove four screws (24) and remove thermostat cover and bracket (23).
 - (2) Tag and disconnect electrical wiring to thermostat (25) and compressor terminal (29).
 - (3) Remove thermostat (25) from compressor. (4) Remove four screws (30) and remove terminal (29) and gasket (28). Discard gasket.
 - (4) Remove four screws (30) and remove terminal (29) and gasket (28). Discard gasket.
 - (5) Install new thermostat (25).
 - (6) Use a new gasket (28) and install terminal (29) with four screws (30). Torque capscrews to 18 ft-lb.
- c. Replace suction (service) valve package (16) and/or discharge (service) valve package (1).

WARNING

Make sure valve package(s) being replaced have been isolated from the system and refrigerant charge removed from line(s). System cannot be pumped down when replacing discharge service valve.

- (1) Suction (service) valve package (16):
 - (a) Make sure system has been pumped down (Item 10, Table 4-1).
 - (b) Remove four capscrews (18) to disconnect suction valve (19) from motor end cover (15).
 - (c) Remove and discard gasket (20).

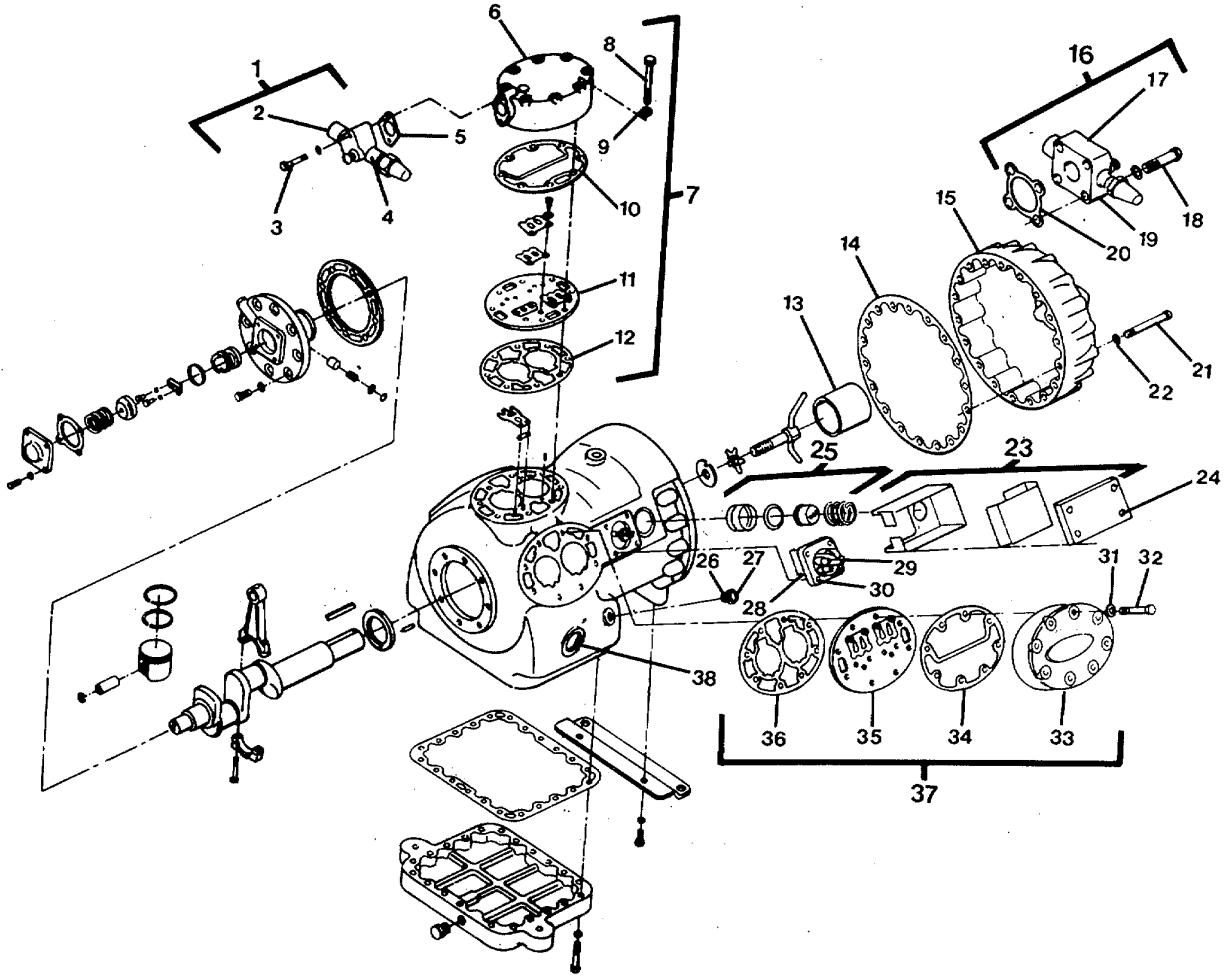

Figure 4-19 . Compressor Unit (A/C-2) .

- (d) Disconnect brazed fitting (17) from refrigerant suction line and remove valve (19).
- (e) Position and connect new valve (19) to suction line at brazed fitting (17).

WARNING

Allow brazed connections to cool before handling to avoid burn injury.

- (f) Make sure gasket surfaces on valve and motor end cover are clean.
 - (g) Coat new gasket (20) with clean compressor oil.
 - (h) Position gasket (20) and install valve (19) to motor end cover (15) with four capscrews (18). Torque capscrews to 18 ft-lb.
- (2) Discharge (service) valve package (1):

WARNING

PRESSURIZED GAS HAZARD. Remove charge before replacing discharge service valve.

- (a) Remove complete charge from system (paragraph 4-10).
- (b) Remove two capscrews (3) to disconnect discharge valve (4) from cylinder head (6).
- (c) Remove and discard gasket (5).
- (d) Disconnect brazed fitting (2) from refrigerant discharge line and remove valve (4).
- (e) Position and connect new discharge valve (4) to refrigerant discharge line at brazed connection (2).

WARNING

Allow brazed connections to cool before handling to avoid burn injury.

- (f) Make sure gasket surfaces on valve and cylinder head are clean.
- (g) Coat new gasket (5) with clean compressor oil.
- (h) Position gasket (5) and install valve (4) to cylinder head (6) with two capscrews (3). Torque capscrews to 18 ft-lb.

- d. Remove cylinder head valve plate assembly (7) and/or compressor head valve plate package(s) (37).
- (1) Cylinder head valve plate assembly (7):
 - (a) Disconnect discharge valve (4) from cylinder head (6) (REMOVAL, step c., above).
 - (b) Remove eight capscrews (8) and washers (9) from cylinder head (6).
 - (c) Remove gasket (10), valve plate (11) and gasket (12). Discard gaskets.
 - (d) Make sure all gasket sealing surfaces are clean.
 - (e) Coat new gaskets (10) and (12) with clean compressor oil.
 - (f) Position gasket (12), valve plate (11), and gasket (10) on compressor. Align with capscrew holes.
 - (g) Install cylinder head (6) with eight capscrews (8) and washers (9). Torque capscrews alternately to 33 ft-lb.
 - (2) Compressor head valve plate package(s) (37):
 - (a) Remove eight capscrews (32) and washers (31) from compressor head (33).
 - (b) Remove gasket (34), valve plate (35), and gasket (36). Discard gaskets.
 - (c) Make sure all gasket sealing surfaces are clean.
 - (d) Coat new gaskets (34) and (36) with clean compressor oil.
 - (e) Position gasket (36), valve plate (35), and gasket (34) on compressor. Align with capscrew holes.
 - (f) Install compressor head (33) with eight capscrews (32) and washers (31). Torque capscrews alternately to 33 ft-lb.
- e. Replace oil fill plug gasket (26):

WARNING

If compressor is not removed, make sure crankcase is isolated and charge removed before removing fill plug (Removal step a.9 above).

- (1) Remove oil fill plug (27) from compressor. Remove gasket (26) and discard.
- (2) Coat new gasket (26) with clean compressor oil.
- (3) Position gasket on fill plug (27).
- (4) Install fill plug in compressor. Torque to 22 ft-lb.

- f. Replace motor end cover gasket (14):
- (1) Disconnect suction valve (19) from motor end cover (15) (Removal, step b., above).
 - (2) Remove 18 capscrews (21) and washers (22) and remove motor end cover (15).
 - (3) Remove gasket (14) and discard.
 - (4) Remove suction strainer (13) from motor end cover (15) and clean with mineral spirits. Allow strainer to dry and coat with clean compressor oil. Install strainer back in motor end cover.
 - (5) Make sure gasket sealing surfaces are clean.
 - (6) Coat gasket (14) with clean compressor oil.
 - (7) Align gasket (14) and install motor end cover (15) with 18 capscrews (21) and washers (22). Torque capscrews alternately to following values:
 - (a) Torque all capscrews to 15 ft-lb; then,
 - (b) Torque to 35 ft-lb; then,
 - (c) Torque to 57 ft-lb.
- g. Replace compressor plate gasket (7, FIGURE 4-20), assembly relief valve (13) and/or safety relief valve (14), and check valve piston (4) and spring (5):
- (1) Remove compressor (See removal steps, above).
 - (2) Remove 22 capscrews (10) and washer (9).
 - (3) Remove plate (8) and gasket (7) from compressor (1).
 - (4) Disconnect oil strainer (11) from oil suction tube (12) from inside crankcase. Disconnect oil suction tube (12) from oil pump.
 - (5) Remove assembly relief valve (package) (13), along with safety relief valve (14) from inside crankcase.
 - (6) Remove two screws (6) from mounting package (3) and remove check valve assembly (2).
 - (7) Remove check valve piston (4) and check valve spring (5).
 - (8) Pre-lube all parts with clean compressor oil.
 - (9) Install new check valve spring (5) and check valve piston (4) in check valve assembly (2).
 - (10) Install mounting package (3) with two screws (6).

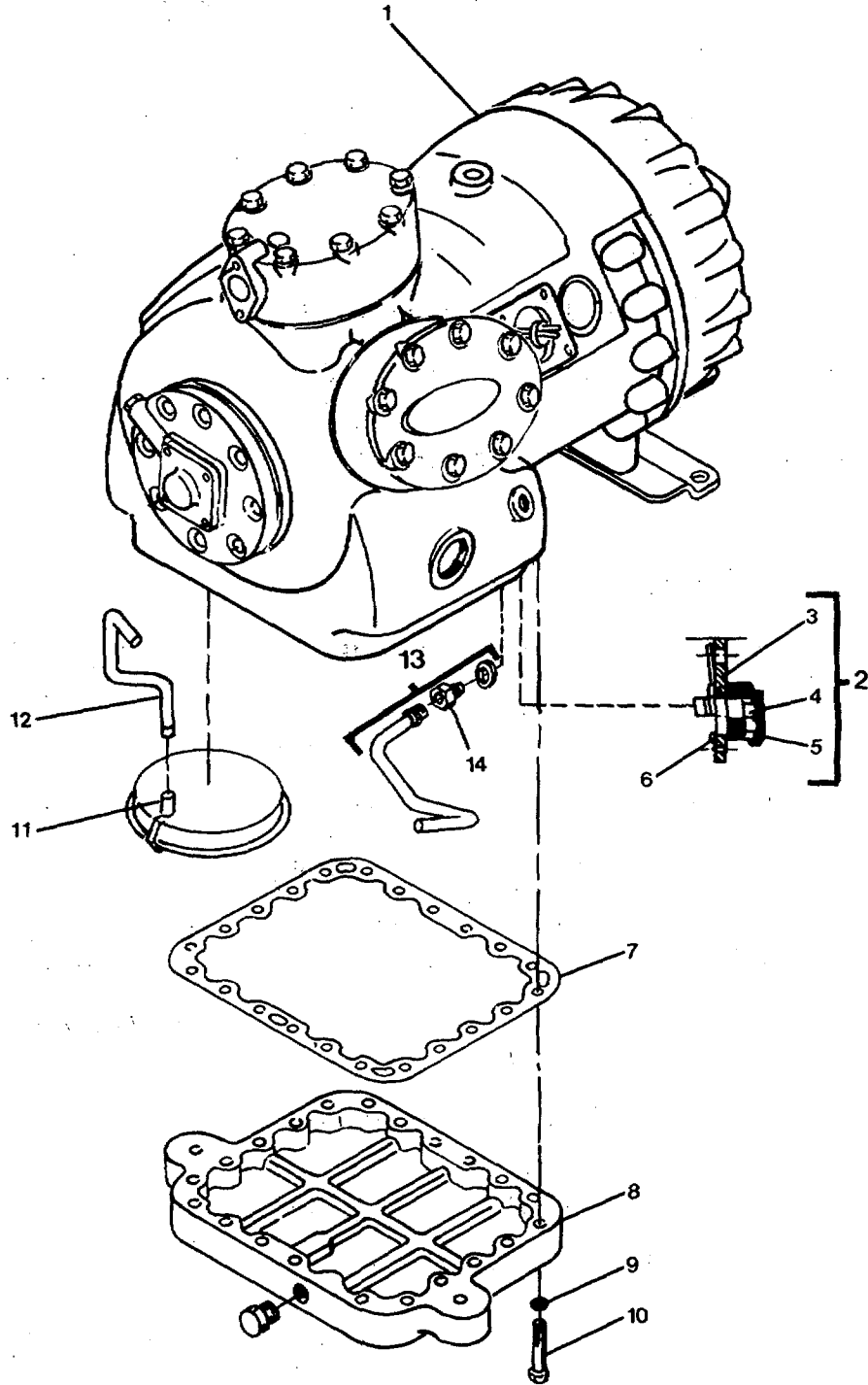

Figure 4-20. Replacing Crankcase Component .

- (11) Install assembly relief valve (package) (13). Safety relief valve (14) installed with package.
 - (12) Connect oil suction tube (12) to oil pump inside crankcase. Connect oil strainer (11) to suction tube (12).
 - (13) Coat gasket (7) with clean compressor oil.
 - (14) Align gasket (7) and install compressor plate (8) to compressor (1) with 22 capscrews (10) and washers (9).
 - (15) Torque capscrews alternately from side to side to following values:
 - (a) Torque to 10 ft-lb; then,
 - (b) Torque to 20 ft-lb, then,
 - (c) Torque to 28 ft-lb.
 - (16) Replace compressor (REPLACEMENT steps in this procedure).
- h. Replace pump and bearing head assembly (1, FIGURE 4-21):
- (1) Remove pump and bearing head assembly as follows: Remove eight capscrews (6) and washers (5) and remove oil pump bearing head (4) and gasket (3) from compressor (2).
 - (2) Install pump and bearing head assembly as follows:
 - (a) Make sure all gasket sealing surfaces are clean.
 - (b) Coat all parts and gaskets with clean compressor oil.
 - (c) Position gasket (3) on compressor (2) and install pump and bearing head (4) with eight capscrews (6) and washers (5). Torque capscrews alternately to following values:
 - 1 Torque to 10 ft-lb; then,
 - 2 Torque to 20 ft-lb; then,
 - 3 Torque to 28 ft-lb.
- i. Replace crankshaft (8, FIGURE 4-22), rotor drive key (5), connecting rod and cap assembly (10, 9, 16), and compressor piston (13) and rings (14, 5).
- (1) Remove compressor (See REMOVAL steps, above).
 - (2) Remove cylinder head and compressor heads (REPAIR, step d. , above).
 - (3) Remove motor end cover, gasket, and suction strainer (REPAIR, step f. above).

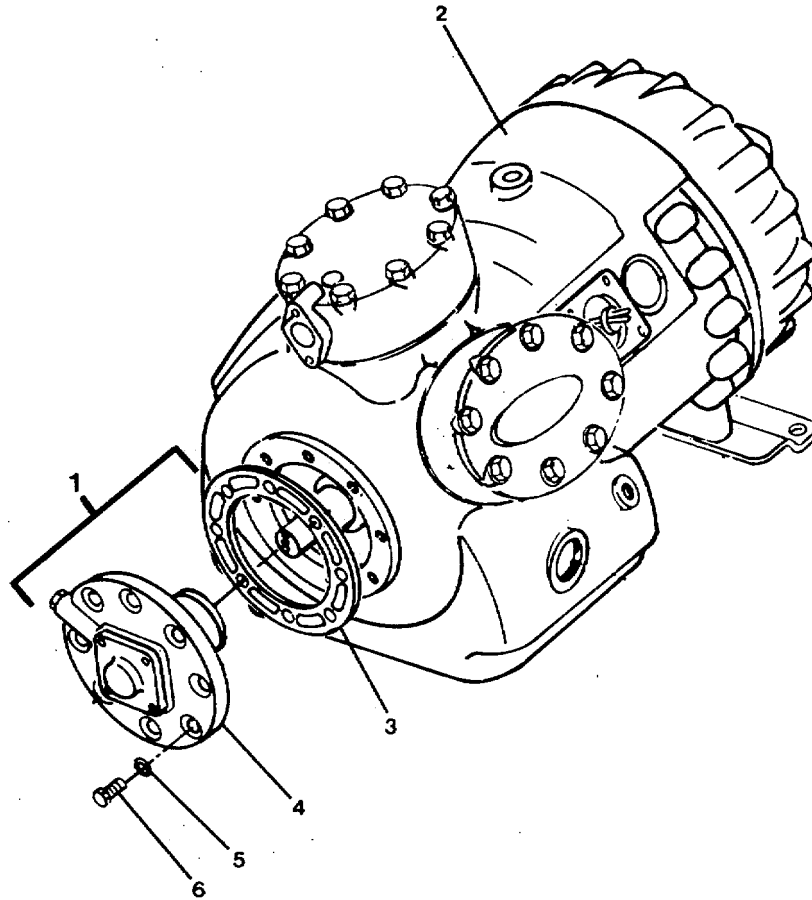

FIGURE 4-21. *Replacing Pump and Bearing Assembly.*

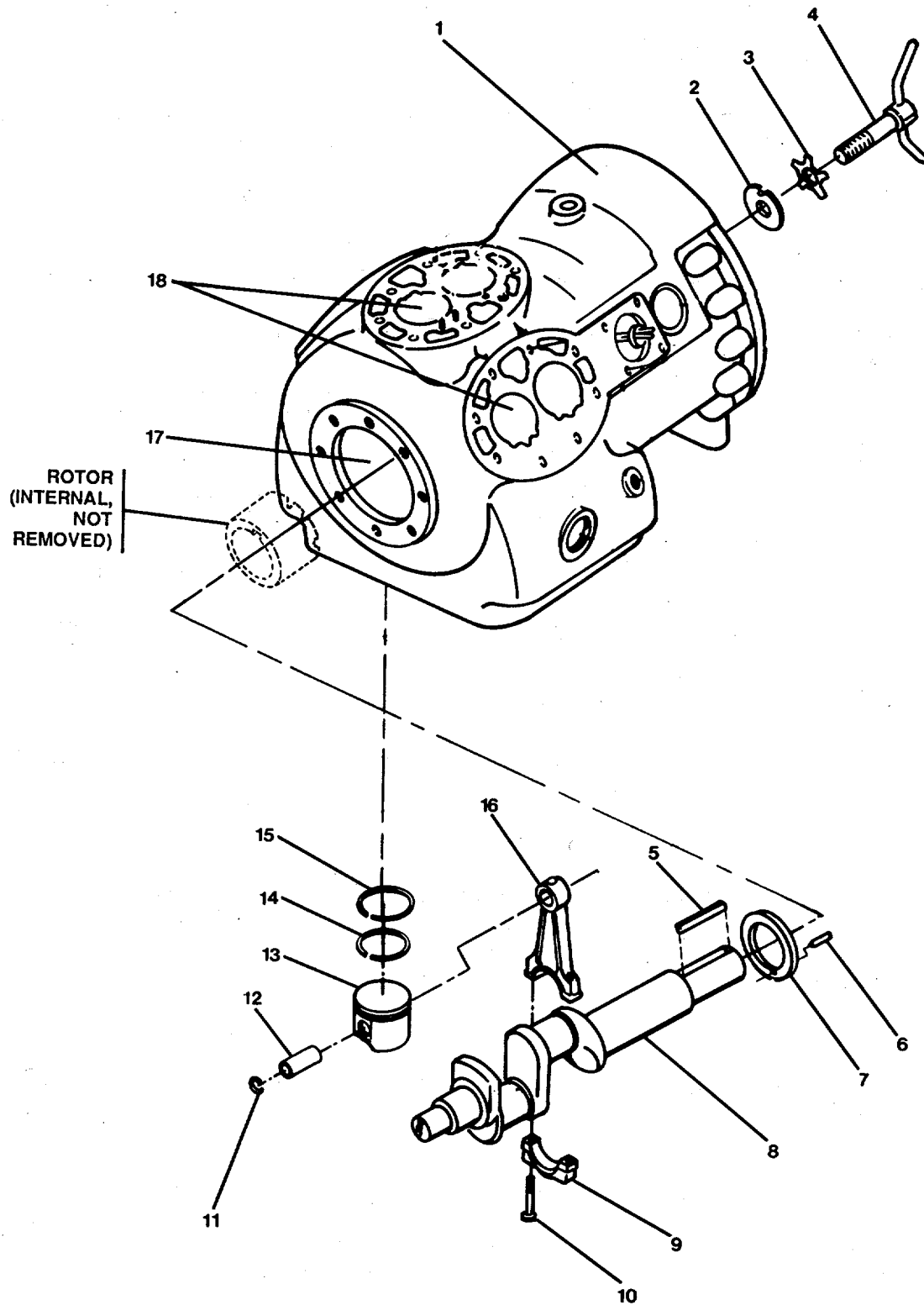

FIGURE 4-22. Replacing Crankshaft, Pistons, and Connecting Rods.

- (4) Remove compressor plate, gasket, and oil suction strainer and tube (REPAIR, step g. , above).
- (5) Remove the equalizing tube (4) by unscrewing counterclockwise. Remove the key washers (3) and (2).
- (6) Remove crankshaft (8), piston and rings (13, 14, 15), connecting rod assembly (10, 9, 16) and rotor drive key (5) as follows:
 - (a) Remove two capscrews (10) from each connecting rod cap (9) and remove all six rod caps.
 - (b) Remove pump and bearing assembly (REPAIR, step h. of this procedure).
 - (c) Remove piston and connecting rod assemblies from compressor cylinders (18).
 - (d) Remove crankshaft (8) by sliding it out through the pump and bearing head opening (17) on the compressor (1).
 - (e) Remove washer (7), crankshaft pin (6); and rotor drive key (5) from crankshaft (8).
 - (f) Remove retaining ring (11) from each end of piston pin (12).
 - (g) Remove piston pin (12) to disconnect piston (13) from connecting rod (16).
 - (h) Remove rings (15, 14) from piston (13).
- (7) Install rings (14, 15), piston (13), connecting rod assembly (16, 9, 10), crankshaft (8), and rotor drive key (5) as follows:
 - (a) Install ring (14) and (15) on piston (13).
 - (b) Connect piston (13) to connecting rod (16) by installing piston pin (12) through piston and connecting rod. Install a retaining ring (11) to each end of the piston pin (12).
 - (c) Place washer (7), rotor drive key (5), and crankshaft pin (6) on crankshaft (8).
 - (d) Install crankshaft (8) through pump and bearing head opening (17) on compressor (1). Make sure the rotor drive key (5) is aligned when installing.
 - (e) Install pump and bearing assembly (REPAIR, step h. , above).
 - (f) Use the ring compressor from refrigeration tool kit and install piston, and connecting rod assemblies into cylinders (18).
 - (g) Install rod cap (9) to each connecting rod (16) with two capscrews (10). Torque capscrews to 9 ft-lb.

- (8) Install key washers (2, 3) and equalizing tube (4). Screw tube clockwise to install. Secure tube until snug.
- (9) Install oil suction tube and strainer, and, compressor plate and gasket (REPAIR, step g. above).
- (10) Install motor end cover, gasket, and suction strainer (REPAIR, step f. , above).
- (11) Install cylinder head and compressor heads (REPAIR, step d. above).
- (12) Install compressor (see REPLACEMENT steps in this procedure).

REPLACEMENT

- a. Position compressor (10, FIGURE 4-17) and install two mounting bolts (12). and two mounting bolts (9). Torque bolts to 28 ft-lb.
- b. Connect oil pressure switch to compressor (paragraph 4-14).
- c. Connect electrical wiring to proper connections in terminal box (4, FIGURE 4-17).
- d. Connect discharge valve (1, FIGURE 4-17) to compressor (10):
 - (1) Use new gasket (3) and capscrews (12) furnished with new compressor.
 - (2) Make sure gasket sealing surfaces are clean.
 - (3) Coat gasket (3) with clean compressor oil.
 - (4) Position gasket (3) and connect discharge valve (1) to compressor (10) with two capscrews (12). Torque to 18 ft-lb.
- e. Connect suction valve (7, FIGURE 4-17) to compressor (10):
 - (1) Use new gasket (5) and capscrews (6) furnished with new compressor.
 - (2) Coat gasket (5) with clean compressor oil.
 - (3) Make sure gasket sealing surfaces are clean.
 - (4) Position gasket (5) and connect suction valve (7) to compressor (10) with four capscrews (6). Torque to 18 ft-lb.

NOTE

A new compressor is shipped with the proper amount of compressor oil already added.

- f. Remove fill plug (27, FIGURE 4-19) and add new compressor oil until level is at the half-way point in the observation window (38). Install fill plug (27) and torque to 22 ft-lb.
- g. Evacuate and add refrigerant charge to compressor as follows:
 - (1) Connect the common hoseline of a portable gauge manifold to the suction connection (7, FIGURE 4-23) of a portable vacuum pump (6).
 - (2) Connect the high pressure hoseline on the gauge manifold to the charging port (4) on the discharge valve.
 - (3) Connect the compound (suction pressure) hoseline of the gauge manifold to the charging port (9) on the suction valve.
 - (4) Make sure caps (5) and (8) are removed for access to valve stems.
 - (5) Close gauge port handwheels (1) and (3) fully clockwise.
 - (6) Start the portable vacuum pump (6). Open gauge port handwheels (1) and (3) counterclockwise one-half to one turn.
 - (7) Watch the combination gauge (2). When the pressure has decreased to 3 inches vacuum on the gauge, close gauge port handwheels (1) and (3) fully clockwise.
 - (8) Turn the portable vacuum pump OFF.
 - (9) Disconnect the common hoseline on the gauge manifold from the suction connection (9) on the vacuum pump (8).
 - (10) The compressor has now been evacuated and is ready to have R-22 refrigerant charge added.

WARNING

PRESSURIZED GAS HAZARD. Handle R-22 refrigerant containers with care to avoid personal injury. Keep containers away from external heat sources. DO NOT DROP containers. When in use, place containers where they will not be knocked over.

- (11) Connect the common hoseline on the gauge manifold to valve connection (8, FIGURE 4-24) on a R-22 refrigerant container (7).
- (12) Purge hoses.
- (13) Open gauge port handwheels (1) and (3) counterclockwise one-half to one turn.
- (14) Slowly open the valve (6) on the refrigerant container (7). A hissing sound can be heard as refrigerant passes from container to compressor.
- (15) When hissing sound has stopped, close gauge port handwheels (1) and (3) fully clockwise.

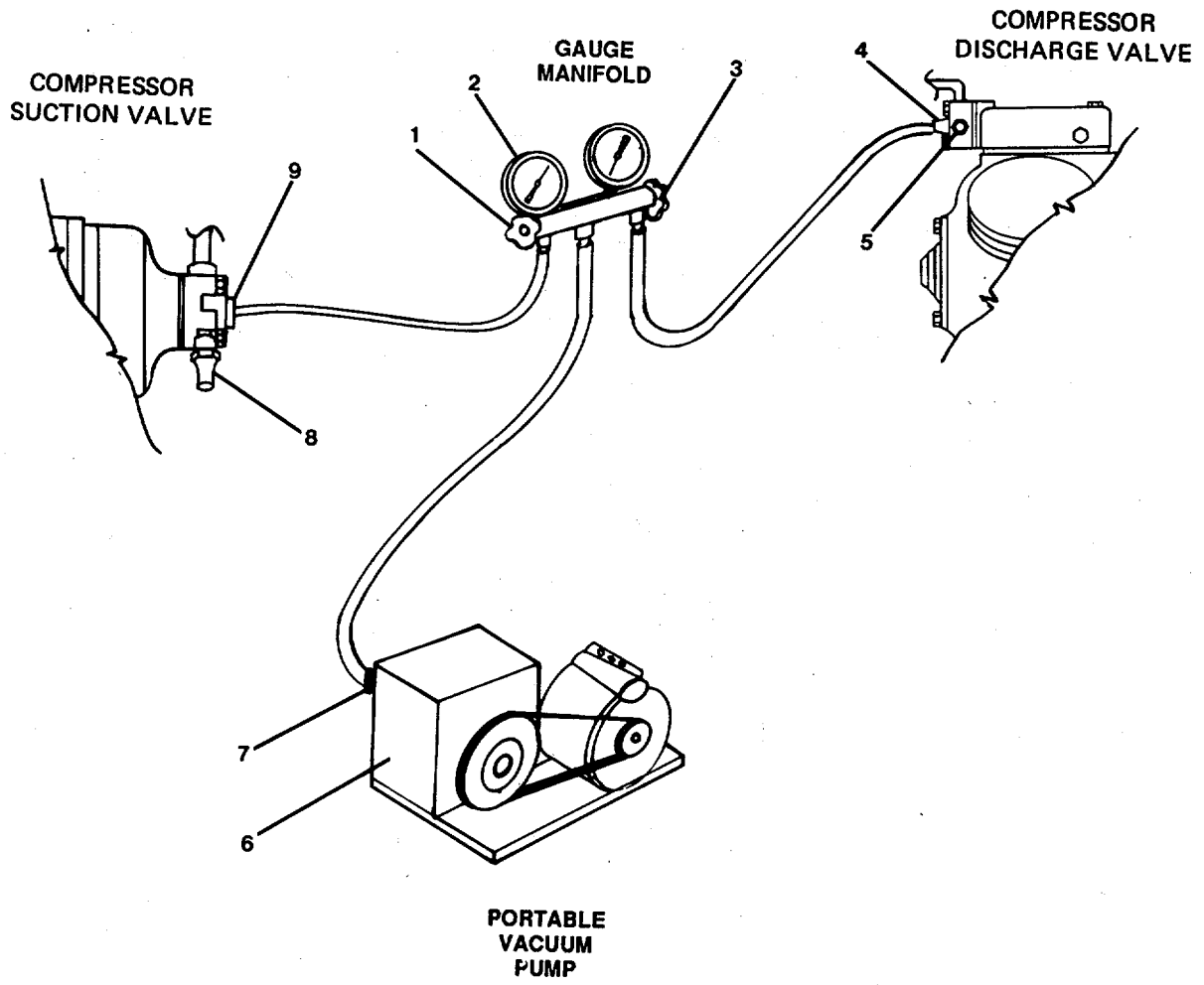

FIGURE 4-23. *Evacuating Compressor.*

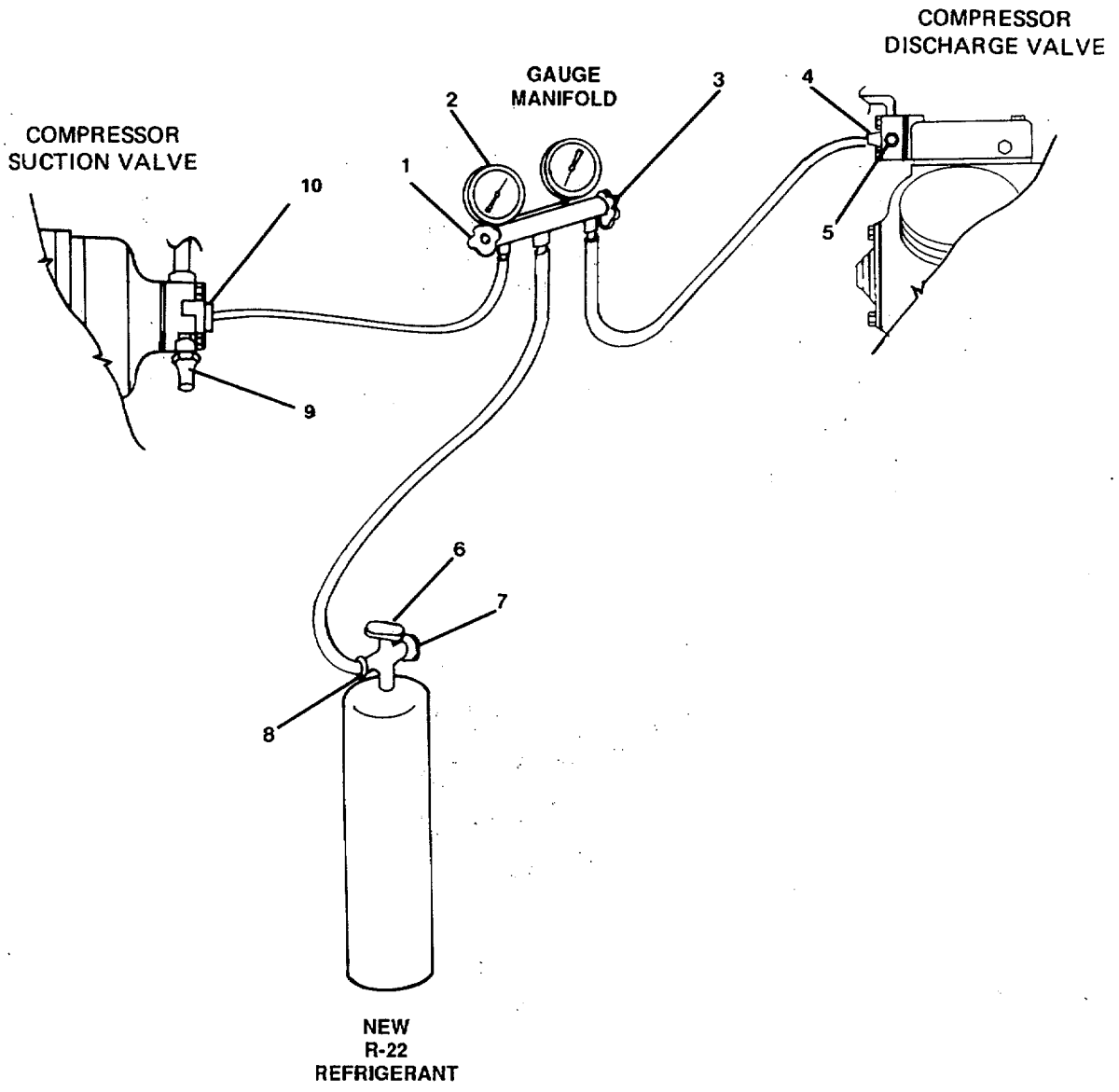

FIGURE 4-24. *Adding Refrigerant to Compressor.*

- (16) Close valve (6) on refrigerant container (7) fully clockwise.
 - (17) With caps (5) and (9) removed for access to valve stems, slowly open both suction and discharge valve stems three turns counterclockwise. The compressor is no longer isolated from the system.
 - (18) Leave portable gauge manifold hooked up and restore electrical power to the air conditioner assembly.
 - (19) Start and run the compressor.
 - (20) Add R-22 refrigerant as necessary to bring operating pressures to normal:
 - (a) Normal Suction Pressure = 58 to 72 psig (See 2, FIGURE 4-16).
 - (b) Normal Discharge Pressure = 190 to 250 psig (See 3, FIGURE 4-16).
 - (21) Add additional R-22 refrigerant, by first opening the valve (6, FIGURE 4-24) on refrigerant container (7); then slowly opening gauge port handwheel (1) on the gauge manifold counterclockwise one-half to one turn. When operating pressures are within normal range, close gauge port handwheel.
 - (22) Observe the refrigerant sight glass in the liquid line. If bubbles, or an intermittent stream of bubbles (FIGURE 4-25) are present, add additional refrigerant until sight glass shows clear. Do not add refrigerant after sight glass clears.
 - (23) Close valve (6) on refrigerant container (7).
 - (24) Turn suction valve stem and discharge valve stem fully counterclockwise and install valve caps (9) and (5).
 - (25) Purge lines before disconnecting.
 - (26) Disconnect gauge manifold hoses from connections (10), (4), and (8).
- h. Remove "Out of Service" tag from circuit.

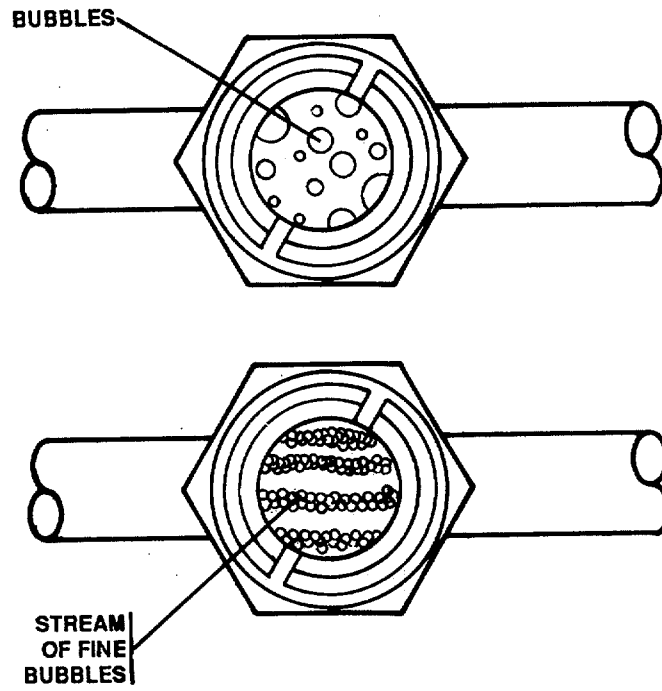

FIGURE 4-25. Low Refrigerant Charge.

SECTION VI. PREPARATION FOR STORAGE OR SHIPMENT

4-20. Refer to Chapter 2, Section VI.

4-77/(4-78 blank)

APPENDIX A**REFERENCES**

A-1. **Scope.** This paragraph lists the manuals, bulletins, specifications, and miscellaneous publications referenced in this manual or required for maintenance activities.

A-2. **Field Manuals.**

FM 21-11	First Aid for Soldiers
FM 31-70	Basic Cold Weather Manual
FM 55-501	Marine Crewman's Handbook

A-3. **Technical Manuals.**

TM 43-0139	Painting Instructions for Field Use
TM 55-1905-223-10	Operator's Manual for Landing Craft, Utility (LCU)
TM 55-1905-223-24-18	Repair Parts and Special Tools List for the LCU 2000 Class Watercraft
TM 750-244-3	Destruction of Army Materiel to Prevent Enemy Use

A-4. **Technical Bulletins.**

TB 43-0144	Painting of Vessels
TB 550-1900-207-24	Treatment of Cooling Water in Marine Diesel Engines
TB 740-97-4	Preservation of Vessels for Storage

A-5. **Military Specifications.**

MIL-C-16173C	Rust Preventive, Type P-1
MIL-L-644	Preservative Oil, Type P-9
MIL-L-21260	Preservative Oil, Type P-10

A-6. **Miscellaneous Publications.**

DA Form 2028 and DA Form 2028-2	Recommended Changes to Publications and Blank Forms
DA Form 2404	Equipment Maintenance and Inspection Worksheet
DA Form 2408-16	Logsheet
DA Form 2410	Logsheet
SF Form 368	Quality Deficiency Report

*Supercedes Darcom-R 750-11

A-1/(A-2 blank)

Appendix B. MAINTENANCE ALLOCATION CHART (MAC)

Section I. INTRODUCTION

B-1 THE ARMY MAINTENANCE SYSTEM MAC.

a This introduction (Section I) provides a general explanation of all maintenance and repair functions authorized at various maintenance levels under the standard Army Maintenance System concept.

b The Maintenance Allocation Chart (MAC) in Section II designates overall authority and responsibility for the performance of maintenance functions on the identified end item or component. The application of the maintenance functions to the end item or component will be consistent with the capacities and capabilities of the designated maintenance levels, which are shown in the MAC in column (4) as:

Unit - includes two subcolumns: C (operator/crew) and O (unit) maintenance.

Direct Support - includes an F subcolumn.

General Support - includes an H subcolumn.

Depot - includes a D subcolumn.

c Section III lists the tools and test equipment (both special tools and common tools sets) required for each maintenance function as referenced from Section II.

d Section IV contains supplemental instructions and explanatory notes for a particular maintenance function as referenced from Section II.

B-2 MAINTENANCE FUNCTIONS . Maintenance functions will be limited to and defined as follows:

a Inspect. To determine the serviceability of an item by comparing its physical, mechanical, and/or electrical characteristics with established standards through examination (i. e. , by sight, sound, or feel).

b Test. To verify serviceability by measuring the mechanical, pneumatic, hydraulic, or electrical characteristics of an item and comparing those characteristics with prescribed standards.

c Service. Operations required periodically to keep an item in proper operating condition, i. e. , to clean (includes decontamination, when required), to replace filters, to preserve, to drain, to paint, or to replenish fuel, lubricants, chemical fluids, or gases.

d Adjust. To maintain or regulate, within prescribed limits, by bringing into proper or exact position, or by setting the operating characteristics to specified parameters.

e Align. To adjust specified variable elements of an item to bring about optimum or desired performance.

f Calibrate. To determine and cause corrections to be made or to be adjusted on instruments or test, measuring, and diagnostic equipment used in precision measurement. Consists of comparisons of two instruments, one of which is a certified standard of known accuracy, to detect and adjust any discrepancy in the accuracy of the instrument being compared.

g Remove/Install. To remove and install the same item when required to perform service or other maintenance functions. Install may be the act of emplacing, seating, or fixing into position a spare, repair part, or module (component or assembly) in a manner to allow the proper functioning of an equipment or system.

h Replace. To remove an unserviceable item and install a serviceable counterpart in its place. Replace is authorized by the MAC and is shown as the 3rd position code of the SMR code.

Change 3 B-1

i Repair. The application of maintenance services¹ including fault location/trouble-shooting², removal/installation, and disassembly/assembly³ procedures, and maintenance actions⁴ to identify troubles and restore serviceability to an item by correcting specific damage, fault, malfunction, or failure in a part, subassembly, module (component or assembly), and item, or system.

j Overhaul. That maintenance effort (service/action) prescribed to restore an item to a completely serviceable/operational condition as required by maintenance standards in appropriate technical publications (i. e. , DMWR). Overhaul is normally the highest degree of maintenance performed by the Army. Overhaul does not normally return an item to like new condition.

k Rebuild. Consists of those service/actions necessary for the restoration of unserviceable equipment to a like new condition in accordance with original manufacturing standards. Rebuild is the highest degree or material maintenance applied to Army equipment. The rebuild operation includes the act of returning to zero those age measurements (hours, miles, etc.) considered in classifying Army equipment and components.

B-3 EXPLANATION OF COLUMNS IN THE MAC, SECTION II

a Column 1 - Group Number. Column 1 lists functional group code numbers, the purpose of which is to identify maintenance significant components, assemblies, subassemblies, and modules with the next higher assembly.

b Column 2 - Component/Assembly. Column 2 contains the names of components, assemblies, subassemblies, and modules for which maintenance is authorized.

c Column 3 - Maintenance Function. Column 3 lists the functions to be performed on the item listed in column 2. (For detailed explanation of these functions, see paragraph A-2.)

d Column 4 - Maintenance Category. Column 4 specifies, by the listing of a work time figure in the appropriate subcolumn(s), the category of maintenance authorized to perform the function listed in Column 3. This figure represents the active time required to perform that maintenance function at the indicated category of maintenance. If the number or complexity of the tasks within the listed maintenance function varies at different maintenance categories, appropriate work time figures will be shown for each category. The work time figure represents the average time required to restore an item (assembly, subassembly, component, module, end item, or system) to a serviceable condition under typical field operating conditions. This time includes preparation time (including any necessary disassembly/assembly time), troubleshooting/fault location time, and quality assurance/quality control time in addition to the time required to perform the specific tasks identified for the maintenance functions authorized in the maintenance allocation chart. The symbol designations for the various maintenance categories are as follows:

- C Operator or Crew
- O Unit Maintenance
- F Direct Support Maintenance (DS)
- H General Support Maintenance (GS)
- D Depot Maintenance

¹Service - Inspect, test, service, adjust, align, calibrate, and/or replace.

²Fault location/troubleshooting - The process of investigating and detecting the cause of equipment malfunctioning; the act of isolating a fault within a system or unit under test (UUT).

³Disassembly/assembly - The step-by-step breakdown (taking apart) of a spare/functional, group coded item to the level of its least component, that is assigned an SMR code for the level of maintenance under consideration (i. e. , identification as maintenance significant).

⁴Actions - Welding, grinding, riveting, straightening, facing, machining, and/or resurfacing.

e Column 5 - Tools and Equipment. Column 5 specifies, by number code, those common tool sets (not individual tools); special tools; Test, Measurement, and Diagnostic Equipment (TMDE); and support equipment required to perform the designated function, which shall be keyed to the tools listed in Section III.

f Column 6 - Remarks. This column shall, when applicable, contain a letter code, in alphabetic order, which shall be keyed to the remarks contained in Section IV.

B-4 EXPLANATION OF COLUMNS IN TOOL AND TEST EQUIPMENT REQUIREMENTS, SECTION III.

a Column 1 - Reference Code. The tool and test equipment reference code correlates with a number code used in the MAC, Section II, Column 5.

b Column 2 - Maintenance Category. The lowest category of maintenance authorized to use the tool or test equipment.

c Column 3 - Nomenclature. Name or identification of the tool or test equipment.

d Column 4 - National Stock Number. The National stock number (NSN) of the tool or test equipment.

e Column 5 - Tool Number. The manufacturer's part number.

B-5 EXPLANATION OF COLUMNS IN REMARKS, SECTION IV.

a Column 1 - Reference Code. The letter code recorded in Column 6, Section II.

b Column 2 - Remarks. This column lists information pertinent to the maintenance function being performed as indicated in the MAC, Section II.

Change 3 B-3

**SECTION II. MAINTENANCE ALLOCATION CHART
FOR
ENVIRONMENTAL CONTROL SUBSYSTEM**

(1) GROUP NUMBER	(2) COMPONENT/ ASSEMBLY	(3) MAINTENANCE FUNCTION	(4) MAINTENANCE LEVEL					(5) TOOLS AND EQUIPMENT	(6) REMARKS
			UNIT		DS	GS	DEPOT		
			C	O	F	H	D		
17	ENVIRONMENTAL CONTROL SUBSYSTEM	INSPECT	4.0					3 1 1-3 1-5	O N N, Q R
		SERVICE	4.0						
		ADJUST	4.0			8.0			
		REPLACE			4.0	12.0			
		REPAIR OVERHAUL	8.0	12.0	18.0	24.0	*		
1701	HEATER, DUCT TYPE STATIONARY(DUCT#1)	INSPECT	0.3					1,2 1,2	B A, P, Q
		SERVICE	0.5						
		REPLACE			1.0				
		REPAIR	0.5		1.5				
1702	HEATER, DUCT TYPE STATIONARY (DUCT #2)	INSPECT	0.3					1,2 1,2	B C, P Q
		SERVICE	0.5						
		REPLACE			1.0				
		REPAIR	0.5		1.5				
1703	HEATER, DUCT TYPE STATIONARY (DUCT #3)	INSPECT	0.5					1,2 1,2	B A, P, Q
		SERVICE	0.8						
		REPLACE			1.5				
		REPAIR	0.8		2.0				
1704	HEATER, DUCT TYPE STATIONARY (DUCT #4)	INSPECT	0.3					1,2 1,2	B C, P, Q
		SERVICE	0.5						
		REPLACE			1.0				
		REPAIR	0.5		1.5				
1705	HEATER, DUCT TYPE STATIONARY (DUCT #5)	INSPECT	0.3					1,2 1,2	B C, P, Q
		SERVICE	0.5						
		REPLACE			1.0				
		REPAIR	0.5		1.5				
1706	HEATER, DUCT TYPE STATIONARY (DUCT #6)	INSPECT	0.3					1,2 1,2	B C, P, Q
		SERVICE	0.5						
		REPLACE			1.0				
		REPAIR	0.5		1.5				

**SECTION II. MAINTENANCE ALLOCATION CHART
FOR
ENVIRONMENTAL CONTROL SUBSYSTEM**

(1) GROUP NUMBER	(2) COMPONENT/ ASSEMBLY	(3) MAINTENANCE FUNCTION	(4) MAINTENANCE LEVEL					(5) TOOLS AND EQUIPMENT	(6) REMARKS
			UNIT		DS	GS	DEPOT		
			C	O	F	H	D		
1707	HEATER, DUCT TYPE STATIONARY (DUCT #7)	INSPECT	0.3						
		SERVICE	0.5						B
		REPLACE REPAIR			1.0 1.5			1,2 1,2	C, P, Q
1708	HEATER, DUCT TYPE STATIONARY (DUCT #8)	INSPECT	0.3						
		SERVICE	0.5						B
		REPLACE REPAIR			1.0 1.5			1,2 1,2	C, P, Q
1709	HEATER, DUCT TYPE STATIONARY (DUCT #9)	INSPECT	0.3						
		SERVICE	0.5						B
		REPLACE REPAIR			1.0 1.5			1,2 1,2	C, P Q
1710	HEATER, DUCT TYPE STATIONARY (DUCT#10)	INSPECT	0.3						
		SERVICE	0.5						B
		REPLACE REPAIR			1.0 1.5			1,2 1,2	C, P, Q
1711	HEATER, DUCT TYPE STATIONARY (DUCT#11)	INSPECT	0.3						
		SERVICE	0.5						B
		REPLACE REPAIR			1.0 1.5			1,2 1,2	C, P, Q
1712	HEATER, DUCT TYPE STATIONARY (DUCT #12)	INSPECT	0.3						
		SERVICE	0.5						B
		REPLACE REPAIR			1.0 1.5			1,2 1,2	C, P, Q
1713	HEATER, DUCT TYPE STATIONARY (DUCT #12A)	INSPECT	0.3						
		SERVICE	0.5						B
		REPLACE REPAIR			1.0 1.5			1,2 1,2	C, P Q
1714	HEATER, DUCT TYPE STATIONARY (DUCT#13)	INSPECT	0.3						
		SERVICE	0.5						B
		REPLACE REPAIR			1.0 1.5			1,2 1,2	C, P, Q

**SECTION II. MAINTENANCE ALLOCATION CHART
FOR
ENVIRONMENTAL CONTROL SUBSYSTEM**

(1) GROUP NUMBER	(2) COMPONENT/ ASSEMBLY	(3) MAINTENANCE FUNCTION	(4) MAINTENANCE LEVEL					(5) TOOLS AND EQUIPMENT	(6) REMARKS
			UNIT		DS	GS	DEPOT		
			C	O	F	H	D		
1715	HEATER, DUCT TYPE STATIONARY (DUCT#14)	INSPECT	0.3						B C, P, Q
		SERVICE	0.5					1,2	
		REPLACE REPAIR	0.5		1.0 1.5			1,2	
1716	HEATER, DUCT TYPE STATIONARY (DUCT#15)	INSPECT	0.3						B C, P, Q
		SERVICE	0.5					1,2	
		REPLACE REPAIR	0.5		1.0 1.5			1,2	
1717	HEATER, DUCT TYPE STATIONARY (DUCT #16)	INSPECT	0.3						B C, P Q
		SERVICE	0.5					1,2	
		REPLACE REPAIR	0.5		1.0 1.5			1,2	
1718	HEATER, DUCT TYPE STATIONARY (DUCT#17)	INSPECT	0.3						B C, P, Q
		SERVICE	0.5					1,2	
		REPLACE REPAIR	0.5		1.0 1.5			1,2	
1719	HEATER, SPACE, ELECTRIC (UNITS 1 AND 2)	INSPECT	0.3						B C, P, Q
		SERVICE	0.5					1,2	
		REPLACE REPAIR	0.5		1.0 1.5			1,2	
1720	HEATER, SPACE, ELECTRIC (UNITS 4 AND 10)	INSPECT	0.3						B C, P Q
		SERVICE	0.5					1,2	
		REPLACE REPAIR	0.5		1.0 1.5			1,2	
1721	HEATER, SPACE, ELECTRIC (UNITS 9 AND 11)	INSPECT	0.3						B C, P, Q
		SERVICE	0.5					1.2	
		REPLACE REPAIR	0.5		1.0 1.5			1,2	
1722	HEATER, SPACE, ELECTRIC (UNITS 3 AND 5)	INSPECT	0.3						B C, P, Q
		SERVICE	0.5					1,2	
		REPLACE REPAIR	0.5		1.0 1.5			1,2	

**SECTION II. MAINTENANCE ALLOCATION CHART
FOR
ENVIRONMENTAL CONTROL SUBSYSTEM**

(1) GROUP NUMBER	(2) COMPONENT/ ASSEMBLY	(3) MAINTENANCE FUNCTION	(4) MAINTENANCE LEVEL					(5) TOOLS AND EQUIPMENT	(6) REMARKS
			UNIT		DS	GS	DEPOT		
			C	O	F	H	D		
1723	HEATER, SPACE, ELECTRIC (UNIT 6)	INSPECT	0.3						
		SERVICE	0.5						B
		REPLACE REPAIR	0.5		1.0 1.5			1,2 1,2	C, P, Q
1724	HEATER, SPACE, ELECTRIC (UNIT 7)	INSPECT	0.3						
		SERVICE	0.5						B
		REPLACE REPAIR	0.5		1.0 1.5			1,2 1,2	C,P,Q
1725	HEATER, SPACE, ELECTRIC (UNITS 8 AND 8A)	INSPECT	0.3						
		SERVICE	0.5						B
		REPLACE REPAIR	0.5		1.0 1.5			1,2 1,2	C, P, Q
1726	HEATER, SPACE, ELECTRIC (CONVECTION HEATER 1)	INSPECT	0.3						
		SERVICE	0.4						B
		REPLACE REPAIR			0.8 1.0			1,2 1,2	D, P
1727	HEATER, SPACE, ELECTRIC (CONVECTION HEATERS 2, 3, AND 4)	INSPECT	0.3						
		SERVICE	0.4						B
		REPLACE REPAIR			0.8 1.0			1,2 1,2	D, P
1728	FAN, VENTILATING (EXHAUST FANS 1 AND 2)	INSPECT	0.5						
		SERVICE	0.5						F
		REPLACE REPAIR				3.0 4.0		1,2,3 1,2,3	
172801	MOTOR, ELECTRIC, ALTERNATING CURRENT	INSPECT	0.5						
		SERVICE	0.5						F
		REPLACE REPAIR				1.5 2.0		1,2,3 1,2,3	
1729	FAN, VENTILATING (SUPPLY FANS 1 AND 2)	INSPECT	0.5						
		SERVICE	0.5						F
		ADJUST				1.0		1	E
		REPLACE REPAIR				3.0 4.0		1,2 1,2	

**SECTION II. MAINTENANCE ALLOCATION CHART
FOR
ENVIRONMENTAL CONTROL SUBSYSTEM**

(1) GROUP NUMBER	(2) COMPONENT/ ASSEMBLY	(3) MAINTENANCE FUNCTION	(4) MAINTENANCE LEVEL					(5) TOOLS AND EQUIPMENT	(6) REMARKS
			UNIT		DS	GS	DEPOT		
			C	O	F	H	D		
172901	MOTOR, ELECTRIC, ALTERNATING CURRENT	INSPECT	0.5						F
		SERVICE	0.5						
		REPLACE REPAIR	0.5				1.5 2.0	1,2,3 1,2,3	
1730	FAN, VENTILATING (SUPPLY FAN 3)	INSPECT	0.5						F E G, Q
		SERVICE	0.5						
		ADJUST			1.0			1	
		REPLACE REPAIR	0.5		1.5 2.0			1, 2 1, 2, 4, 5	
173001	MOTOR, ELECTRIC, ALTERNATING CURRENT	INSPECT	0.5						F G, Q
		SERVICE	0.5						
		REPLACE REPAIR	0.5			1.0 1.5		1,2 1,2	
1731	FAN, VENTILATING (SUPPLY FAN 4)	INSPECT	0.5						F H I, Q
		SERVICE	0.5						
		ADJUST	0.8					1	
		REPLACE REPAIR	0.5	1.0 0.5	1.5			1,2 1, 2, 4	
173101	MOTOR, ELECTRIC, ALTERNATING CURRENT	INSPECT	0.5						F I, Q
		SERVICE	0.5						
		REPLACE REPAIR	0.4	0.5	1.0			1,2 1,2, 4, 5	
1732	FAN, VENTILATING (SUPPLY FAN 5)	INSPECT	0.5						F G, Q
		SERVICE	0.5						
		REPLACE REPAIR	0.5	1.0 0.8	1.5			1,2 1,2	
173201	MOTOR, ELECTRIC, ALTERNATING CURRENT	INSPECT	0.5						F G,Q
		SERVICE	0.5						
		REPLACE REPAIR	0.4	0.8	1.0			1,2 1,2	

SECTION II. MAINTENANCE ALLOCATION CHART FOR ENVIRONMENTAL CONTROL SUBSYSTEM

(1) GROUP NUMBER	(2) COMPONENT/ ASSEMBLY	(3) MAINTENANCE FUNCTION	(4) MAINTENANCE LEVEL					(5) TOOLS AND EQUIP	(6) REMARKS
			UNIT		DS	GS	DEPOT		
			C	O	F	H	D		
1733	FAN, VENTILATING (SUPPLY FAN 6)	INSPECT	0.5						
		SERVICE	0.5						
		ADJUST	0.8					1	
		REPLACE		1.0				1,2	
		REPAIR	0.5	0.5	1.5			1,2	
173301	MOTOR, ELECTRIC, ALTERNATING CURRENT	INSPECT	0.5						
		SERVICE	0.5						
		REPLACE REPAIR	0.4	0.5	1.0			1,2 1,2,4	
1733A	FAN, VENTILATING (SUPPLY FAN 7 & 8)	INSPECT REPLACE	0.5	1.0				1,2	
1734	FAN, VENTILATING (EXHAUST FAN 3)	INSPECT	0.5						
		SERVICE	0.5						
		REPLACE		1.0				1,2	
		REPAIR	0.5	0.8	1.5			1,2	
173401	MOTOR, ELECTRIC, ALTERNATING CURRENT	INSPECT	0.5						
		SERVICE	0.5						
		REPLACE REPAIR	0.4	0.8	1.0			1,2 1,2	
1735	FAN, VENTILATING (EXHAUST FAN 4)	INSPECT	0.5						
		SERVICE	0.5						
		ADJUST		0.8				1	
		REPLACE		1.0				1,2	
		REPAIR	0.5	0.5	1.5			1,2,4,5	
173501	MOTOR, ELECTRIC, ALTERNATING CURRENT	INSPECT	0.5						
		SERVICE	0.5						
		REPLACE REPAIR	0.4	0.5	1.0			1,2 1,2	
1736	FAN, VENTILATING (EXHAUST FAN 6)	INSPECT	0.5						
		SERVICE	0.5						
		ADJUST	0.8					1	
		REPLACE		1.0				1,2	
		REPAIR	0.5	0.5	1.5			1,2,4,5	

SECTION II. MAINTENANCE ALLOCATION CHART FOR ENVIRONMENTAL CONTROL SUBSYSTEM

(1) GROUP NUMBER	(2) COMPONENT/ ASSEMBLY	(3) MAINTENANCE FUNCTION	(4) MAINTENANCE LEVEL					(5) TOOLS AND EQUIP	(6) REMARKS
			UNIT		DS	GS	DEPOT		
			C	O	F	H	D		
173601	MOTOR, ELECTRIC, ALTERNATING CURRENT	INSPECT	0.5						
		SERVICE	0.5						F
		REPLACE REPAIR		0.5				1,2 1,2	I,Q
1737	FAN, VENTILATING (EXHAUST FAN 7)	INSPECT	0.5						
		SERVICE	0.5						F
		REPLACE REPAIR		1.0	1.5 2.0			1,2 1,2	J
173701	MOTOR, EXPLOSION PROOF	INSPECT	0.5						
		SERVICE	0.5						F
		REPLACE	1.0					1,2	J
1738	AIR CONDITIONER (AIR CONDITIONER 1)	INSPECT	0.5						
		SERVICE	0.5						K
		REPLACE REPAIR			1.5 1.0			1,2,3 1,2,3	
1739	AIR CONDITIONER (AIR CONDITIONER 2)	INSPECT	1.0						
		SERVICE	0.8					3	K
		REPLACE REPAIR			4.0 4.5			1,2,3 1,2,3,6	I,Q
173901	MOTOR, ELECTRIC	INSPECT	0.4						
		SERVICE	0.5						F
		REPLACE REPAIR			1.0 1.5			1,2 1,2	I,Q
173902	BLOWER	INSPECT	0.5						
		SERVICE	0.5						L
		REPLACE REPAIR			2.0 2.5			1 1	
173903	RECEIVER, LIQUID REFRIGERANT	REPLACE			1.0			1,3,7	
173904	CONDENSER, REFRIGERATED, WATER COOLED	REPLACE REPAIR		1.0		1.5		1,3 1,3	

**SECTION II. MAINTENANCE ALLOCATION CHART
FOR
ENVIRONMENTAL CONTROL SUBSYSTEM**

(1) GROUP NUMBER	(2) COMPONENT/ ASSEMBLY	(3) MAINTENANCE FUNCTION	(4) MAINTENANCE LEVEL					(5) TOOLS AND EQUIPMENT	(6) REMARKS
			UNIT		DS	GS	DEPOT		
			C	O	F	H	D		
173905	COMPRESSOR, REFRIGERATION	INSPECT SERVICE REPLACE REPAIR	0.5 0.5				1.0 2.5	3 1, 2, 3 1,2, 3, 6, 8, 9	M
17390501	VALVE, PACKAGE, SUCTION	REPLACE REPAIR				0.2 0.5		1, 2, 3 1,2, 3	
17390502	VALVE, PACKAGE, DISCHARGE	REPLACE REPAIR				0.2 0.5		1,2,3 1,2,3	
17390503	PISTON, COMPRESSOR	REPLACE REPAIR				0.2 0.5		1,2, 3 1,2, 3	
1740	AIR CONDITIONER (AIR CONDITIONER 3)	INSPECT SERVICE REPLACE REPAIR	0.5 0.5 0.5		1.5 3.0			1, 2, 3 1,2, 3, 6	K

**SECTION III. TOOLS AND TEST EQUIPMENT REQUIREMENTS
FOR
ENVIRONMENTAL CONTROL SUBSYSTEM**

TOOL OR TEST EQUIPMENT REF CODE	MAINTENANCE CATEGORY	NOMENCLATURE	NATIONAL/NATO STOCK NUMBER	TOOL NUMBER
1	C, O, F, H	Tool Kit, General Mechanic's	5180-00-699-5273	(50980)
2	C, O, F, H	Tool Kit, Electrician's	5180-00-391-1087	SC-5180-90-CL-N05
3	C, F, H	Tool Kit, Refrigeration and Air Conditioning	5180-00-596-1474	(80064) 9000S6202-73125ALT2
4	H	Puller	5120-00-516-3120	
5	C, O	Hydraulic Press		(68225) 2009-13
6	H	Torque Wrench (30-300 inch-pounds)	5120-01-092-3278	
7	H	Torque Wrench (0-50 foot-pounds)	5120-01-242-3264	
8	H	Torque Wrench (30-300 foot-pounds)	5120-01-125-5190	
9	H	Portable Vacuum Pump Unit	4310-00-289-5967	

Change 3 B-12

**SECTION IV. REMARKS
FOR
ENVIRONMENTAL CONTROL SUBSYSTEM**

REFERENCE CODE	REMARKS
A	REPAIR AT C-LEVEL IS TO REPLACE FUSES AND HEATING ELEMENTS. REPAIR AT F-LEVEL IS TOTAL REPAIR TO UNIT.
B	SERVICE IS TO CHECK ALL ELECTRICAL CONNECTIONS INCLUDING FIELD AND FACTORY MADE CONNECTIONS FOR TIGHTNESS AT LEAST ONCE EACH YEAR.
C	REPAIR AT C-LEVEL IS REPLACEMENT OF HEATING ELEMENTS. REPAIR AT F-LEVEL IS TOTAL REPAIR TO UNIT.
D	HEATING ELEMENTS ARE HERMETICALLY SEALED.
E	ADJUST FAN BLADES ANY TIME FAN MOTOR IS REPAIRED.
F	LUBRICATE FAN MOTOR AT REGULAR INTERVALS. USE ONLY 1 OR 2 SHOTS WITH A HAND GUN IN MOST CASES.
G	REPAIR AT C-LEVEL IS TO REPLACE BALL BEARING. REPAIR AT F-LEVEL IS TOTAL REPAIR TO UNIT.
H	ADJUST FAN MOTOR WHEN BELT IS REPLACED.
I	REPAIR AT C-LEVEL IS REPLACEMENT OF BELT AND BEARING. REPAIR AT F-LEVEL IS TOTAL REPAIR TO UNIT.
J	REPAIR OF THIS ITEM IS BY REPLACEMENT.
K	CLEAN OR CHANGE FILTER.
L	LUBRICATE DRIVE SHAFT AT REGULAR INTERVALS.
M	MAINTAIN OIL LEVEL.
N	REPLACEMENTS AND REPAIRS ARE TO INDIVIDUAL UNITS OF THE ENVIRONMENTAL CONTROL SUBSYSTEM.
O	ADJUSTMENTS ARE MADE TO INDIVIDUAL UNITS.
P	REPLACE HEATING ELEMENT BY REPLACING HEATING ELEMENT ASSEMBLY.

**SECTION IV. REMARKS
FOR
ENVIRONMENTAL CONTROL SUBSYSTEM**

REFERENCE CODE	REMARKS
Q	REPAIR AT LOWER LEVELS OF MAINTENANCE, OTHER THAN THE LOWEST LEVEL OF COMPLETE REPAIR, IS LIMITED TO TM 55-1905-223-24P-1.
R	DEPOT LEVEL REPAIR / MAINTENANCE WILL BE PERFORMED ON A CASE BY CASE BASIS SUBJECT TO APPROVAL AND FUNDING BY THE NATIONAL MAINTENANCE POINT (NMP).

☆ U.S. GOVERNMENT PRINTING OFFICE: 1994-555-028/00352

Change 3 B-14

APPENDIX C

EXPENDABLE/DURABLE SUPPLIES AND MATERIALS LIST

SECTION I. INTRODUCTION

C-1. Scope. This appendix lists expendable supplies and materials needed to operate and maintain the LCU 2000 Class Watercraft. These items are authorized by CTA 50-970, Expendable/Durable Items (except Medical, Class V, Repair Parts and Heraldic Items), or CTA 8-100, Army Medical Department Expendable Items.

C-2. Explanation of Columns.

a. Column (1)-Item Number. This number is assigned to the entry in the listing and is referenced in the narrative instructions to identify the material (for example, "Use cleaning compound, Item 5, App. C").

b. Column (2)-Level. This column identifies the lowest level of maintenance that requires the listed item.

As applicable:

C-Operator/Crew

O-Organizational Maintenance

F-Direct Support Maintenance

H-General Support Maintenance

c. Column (3)-National Stock Number. This is the National stock number assigned to the item; use it to request or requisition the item.

d. Column (4)-Description. Indicates the Federal item name and, if required, a description to identify the item. The last line for each item indicates the Federal Supply Code for Manufacturers (FSCM) in parentheses followed by the part number.

e. Column (5)-Unit of Measure (U/M). Indicates the measure used in performing the actual maintenance function. This measure is expressed by a two character alphabetical abbreviation (for example, ea, in, pr). If the unit of measure differs from the unit of issue, requisition the lowest unit of issue that will satisfy your requirements.

SECTION III. EXPENDABLE/DURABLE SUPPLIES AND MATERIAL LIST

(1) ITEM NUMBER	(2) LEVEL	(3) NATIONAL STOCK NUMBER	(4) DESCRIPTION	(5) U/M
1	0		Tag, Marking	
2	0		Grease, General Purpose	
3	0		Detergent, Liquid	
4	0		Oil, Lubricating, 20W	
5	0		Crocus Cloth, Fine	
6	0		Rags, Wiping	
7	0		R-22 Refrigerant	
8	0		Compress Oil	

APPENDIX D

TORQUE VALUES

D-1. Scope. SAE capscrews are graded according to the strength of the capscrew. They are marked on the head so the correct strength and torque value are known. The tables in this appendix will list the capscrew markings with correct torque values as well as values for pipe plugs and metric bolts.

CAUTION

When replacing capscrews, always use a capscrew of the same measurement and strength as the capscrew being replaced. Using incorrect capscrews can result in equipment damage. Bolts threaded into aluminum require much less torque.

NOTE

Always use torque values listed in the tables when specific torque values are unknown. The torque values listed in the tables are based on the use of lubricated threads.

Table D-1. Capscrew Markings and Torque Values

Capacity Body Size	SAE Grade #5 Cast Iron or Steel				SAE Grade #6 or #7 Cast Iron or Steel			SAE Grade #8 Cast Iron or Steel		
	Inches-Thread		Torque		Torque		Torque		Torque	
	ft-lb		kgm	N·m	ft-lb	kgm	N·m	ft-lb	kgm	N·m
1/4	-20	8	1.1064	10.8465	10	1.3630	13.5582	12	1.6596	16.2698
	-28	10	1.3830	13.5582				14	1.9362	18.9815
5/16	-18	17	2.3511	23.0489	19	2.6277	25.7605	24	3.3192	32.5396
	-24	19	2.6277	25.7605				27	3.7341	36.6071
3/8	-16	31	4.2873	42.0304	34	4.7022	46.0978	44	6.0852	59.6560
	-24	35	4.8405	47.4536				49	6.7767	66.4351
7/16	-14	49	6.7767	66.4351	55	7.6065	74.5700	70	9.6810	94.9073
	-20	55	7.6065	74.5700				78	10.7874	105.7538
1/2	-13	75	10.3725	101.6863	85	11.7555	115.2445	105	14.5215	142.3609
	-20	85	11.7555	115.2445				120	16.5860	162.6960
9/16	-12	110	15.2130	149.1380	120	16.5960	162.6960	155	21.4365	210.1490
	-18	120	16.5960	162.6960				170	23.5110	230.4860
5/8	-11	150	20.7450	203.3700	167	23.0961	226.4186	210	29.0430	284.7180
	-18	170	23.5110	230.4860				240	33.1920	325.3920
3/4	-10	270	37.3410	366.0660	280	38.7240	379.6240	375	51.8625	508.4250
	-16	295	40.7985	399.9610				420	58.0860	568.4360
7/8	- 9	395	54.6285	535.5410	440	60.8520	596.5520	605	83.6715	820.2590
	-14	435	60.1605	589.7730				675	93.3525	915.1650
1.0	- 8	590	81.5970	799.9220	660	91.2780	894.8280	910	125.8530	1233.7780
	-14	660	91.2780	849.8280				990	136.9170	1342.2420

Table D-1. Capscrew Markings and Torque Values-CONT



Capscrew Head Markings	SAE GRADE #5	OR	SAE GRADE #6 or #7	SAE GRADE #8
				

Table D-2. Pipe Plug Torque Values

Thread	Size		In Aluminum Components		In Cast Iron or Steel Components	
	Actual	O.D.	Torque		Torque	
in	mm	(in)	N·m	(ft-lb)	N·m	(ft-lb)
1/16	8.1	(0.32)	5	(45 in-lb)	15	(10)
1/8	10.4	(0.41)	15	(10)	20	(15)
1/4	13.7	(0.54)	20	(15)	25	(20)
3/8	17.3	(0.68)	25	(20)	35	(25)
1/2	21.6	(0.85)	35	(25)	55	(40)
3/4	26.7	(1.05)	45	(35)	75	(55)
1	33.5	(1.32)	60	(45)	95	(70)
1-1/4	42.2	(1.66)	75	(55)	115	(85)
1-1/2	48.3	(1.90)	85	(65)	135	(100)

Table D-3. Metric Bolt Torque Values

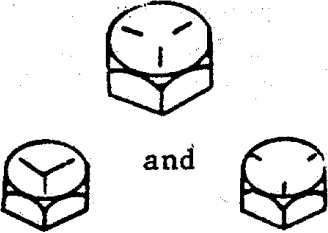
Thread for general purposes (size x pitch (mm))	Cast Iron or Steel			
	Head Mark 4 Torque		Head Mark 7 Torque	
	ft-lb	(N·m)	ft-lb	(N·m)
6 x 1.0	2.2 to 2.9	(3.0 to 3.9)	3.6 to 5.8	(4.9 to 7.8)
8 x 1.25	5.8 to 8.7	(7.9 to 12)	9.4 to 14	(13 to 19)
10 x 1.25	12 to 17	(16 to 23)	20 to 29	(27 to 39)
12 x 1.25	21 to 32	(29 to 43)	35 to 53	(47 to 72)
14 x 1.5	35 to 52	(48 to 70)	57 to 85	(77 to 110)
16 x 1.5	51 to 77	(67 to 100)	90 to 120	(130 to 160)
18 x 1.5	74 to 110	(100 to 150)	130 to 170	(180 to 230)
20 x 1.5	110 to 140	(150 to 190)	190 to 240	(160 to 320)
22 x 1.5	150 to 190	(200 to 260)	250 to 320	(340 to 430)
24 x 1.5	190 to 240	(260 to 320)	310 to 410	(420 to 550)

**Table D-4. Torque for Straight Threaded Tube Fittings,
Hose Fittings, and Plugs with O-Rings"**

**For 37°, 45°, and Inverted Flared Fittings PER SAE Standards
J512, J514, and J516 (See Note)**

Nominal Thread od	Nominal Tube Size	Tightening Torque ft-lb Nuts & Plugs	Torque in-lb Equiv.
5/16	1/8	3.6 ± 0.5	43 ± 6
3/8	3/16	8.6 ± 1.0	103 ± 12
7/16	1/4	12 ± 1.5	144 ± 18
1/2	5/16	15 ± 1.5	180 ± 24
9/16 & 5/8	3/8	18 ± 2	
11/16	7/16	25 ± 3	
3/4	1/2	30 ± 4	
7/8	5/8	40 ± 5	
1-1/16	3/4	55 ± 7	
1-3/16 & 1-1/4	7/8	65 ± 8	
1-5/16 & 1-3/8	1	80 ± 10	
1-5/8	1-1/4	100 ± 12	
1-7/8	1-1/2	120 ± 15	
2-1/2	2	230 ± 30	

NOTE: This chart does not apply to other than the 3 flared designs quoted.

D-3/(D-4 blank)

GLOSSARY**SECTION I. ABBREVIATIONS**

ac	Alternating current
A/C	Air conditioner
ARTC	Automatic reset thermal cutout
CFM	Cubic feet per minute
CH	Convection (electric space) heater
DB	Dry bulb temperature
DH	Duct heater
EF	Exhaust fan
FLA	Full load amps
HVAC	Heating, ventilation, and air conditioning
MRTC	Manual reset thermal cutout
NC	Normal closed
NO	Normal open
psi	Pounds square inch
psig	Pounds square inch gauge
RH	Relative humidity
SF	Supply fan
S.P.	Static pressure
SR	Stateroom
UH	Unit (electric space) heater
WB	Wet bulb temperature
WC	Water closet

SECTION II. DEFINITIONS

Ambient Temperature	- The atmospheric temperature of the immediate surrounding area.
Crustaceous Deposits	- Hard, dry layer of dirt and debris.
Delta.Connected	- Type of internal motor winding connections.
Discharge Side	- The portion of air conditioner refrigerant lines between the compressor and the expansion valve (or strainer and capillary).
Evacuate System	- Pulling a vacuum on the system with a vacuum pump.
Hermetic Compressor	- Totally sealed (welded) compressor unit. Cannot be disassembled for repairs.
High Side	- Same as discharge side.
Low Side	- Same as suction side.
Liquid Line	- The portion of discharge side (high side) line between the receiver and the expansion valve (or strainer and capillary) carrying high pressure liquid refrigerant.
R-22	- Type of freon refrigerant.
Semi-Hermetic Compressor	- A totally sealed (bolted with gaskets) compressor that can be disassembled for replacing parts.
Suction Side	- The portion of air conditioner refrigerant lines between the cooling coil and the compressor carrying low pressure gas refrigerant.

Glossary 2

ALPHABETICAL INDEX

Subject, paragraph

A

Adding Refrigerant, 3-10, 4-10
 Air Coolant
 (A/C #1; Pilothouse)
 Removal, 3-25;
 Repair 2-33, 3-25;
 Replace, 3-25
 (A/C #3; Engine Control Room),
 Removal, 3-25;
 Repair 2-33, 3-25;
 Replace, 3-25
 Air Conditioner Assembly (A/C #2;
 Accommodations),
 Adjust, 4-14;
 Repair 2-34, 4-14

B

Blower (A/C #2),
 Assembly, 4-16;
 Disassembly, 4-16;
 Removal, 4-16;
 Repair, 4-16;
 Replace, 4-16

C

Characteristics, Capabilities, and
 Features, 1-7
 Checking Unpacked Equipment, 2-4, 3-4,
 4-4
 Common Tools and Equipment, 2-1, 3-1,
 4-1
 Compressor, Refrigeration, (Compressor)
 Removal, 4-19;
 Repair, 4-19;
 Replacement, 4-19
 Condenser, Water-Cooled Refrigerating
 Removal, 2-36, 4-18;
 Repair, 4-18;-
 Replace, 2-36, 4-18
 Cooling Cycle and Major Components,
 1-16
 Corrective Maintenance Instructions,
 3-10, 4-10

Subject, paragraph

D

Deprocessing Unpacked Equipment,
 2-5
 Destruction of Materiel, 1-3

E

Equipment Data, 1-9
 Evacuating System
 (A/C-1 and 3), 3-10
 (A/C-2), 4-10
 Exhaust Air System, 1-13
 Extended Shutdown or Storage, 2-37

F

Fan, Ventilating, Exhaust
 (EF #1 and 2),
 Assembly, 4-11;
 Disassembly, 4-11;
 Removal, 4-11;
 Repair, 4-11;
 Replace, 4-11
 (EF #3),
 Removal, 2-30;
 Repair, 2-30, 3-23;
 Replace, 2-30
 (EF #4 and 6),
 Adjust 2-31;
 Removal, 2-31;
 Repair 2-31; 3-24
 Replace 2-31
 (EF #7),
 Removal 2-32;
 Repair 2-32;
 Replace 2-32
 Fan, Ventilating, Supply
 (SF #1 and 2),
 Assembly, 4-13;
 Disassembly, 4-13;
 Removal, 4-13;
 Repair, 4-13;
 Replace, 4-13
 (SF #3),
 Removal, 3-17

ALPHABETICAL INDEX - CONT

Subject, Paragraph

Subject, Paragraph

F-Cont

H-Cont

Repair, 2-24, 3-17;
 Replace, 3-17
 (SF #4),
 Adjust, 2-25;
 Repair, 2-25, 3-19;
 Removal, 2-25;
 Replace, 2-25
 (SF #5)
 Repair, 2-27; 3-21
 Removal, 2-27;
 Replace, 2-27;
 (SF #6)
 Adjust, 2-28;
 Repair, 2-82, 3-22;
 Removal, 2-28;
 Replace, 2-28
 (SF #7 & 8)
 Removal, 2-29.1;
 Replacement, 2-29.1

(DH #12), Repair, 2-20, 3-13
 (DH #12A), Repair, 2-20, 3-13
 (DH #13), Repair, 2-21, 3-13
 (DH #14), Repair, 2-20, 3-13
 (DH #15), Repair, 2-21, 3-13
 (DH #16), Repair, 2-20, 3-13
 (DH #17), Repair, 2-20, 3-12
 Heater, Space, Electric
 (UH 1, 2, 4, 9, 10, and 11),
 Repair, 2-22, 3-14
 Heater, Space, Electric
 (UH #3, 5, 6, and 7)
 Repair, 2-23, 3-15
 Heater, Space, Electric, Convection
 (CH #1, 2, 3, and 4)
 Repair, 3-16

Function of HVAC Accessories, 1-17

Initial Setup Procedure, 2-6, 3-5, 4-5

G

I

Galley Make-up and Exhaust Air, 1-5
 General Description, 1-6

Leak Test, 3-10, 4-10
 Liquid Refrigerant Receiver,
 Removal, 4-17
 Replacement, 4-17
 Location and Description of Major Components, 1-8

H

L

Heater, Duct Type
 (DH #1),
 Removal, 3-11;
 Repair, 2-17, 3-11;
 Replace, 3-11
 (DH #2), Repair, 2-18, 3-12
 (DH #3), Repair, 2-19, 3-12
 (DH #4), Repair, 2-20, 3-13
 (DH #5), Repair, 2-20, 3-13
 (DH #6), Repair, 2-20, 3-13
 (DH #7), Repair, 2-20, 3-13
 (DH #8), Repair, 2-21, 3-13
 (DH #9), Repair, 2-20, 3-13
 (DH #10), Repair, 2-20, 3-13
 (DH #11), Repair, 2-20, 3-13

Maintenance Forms, Records, and Reports, 1-2
 Maintenance Procedures, 2-16, 3-10, 4-10
 Motor, Electric
 Removal, 4-15
 Repair, 4-15
 Replace, 4-15
 Motor, Electric, (A/C #2)
 Repair, 2-35

ALPHABETICAL INDEX-CONT

Subject, paragraph

Subject, paragraph

M-CONT

Motor, Electric, Alternating Current
 (EF #1 and 2),
 Assembly, 4-12;
 Disassembly, 4-12;
 Removal, 4-12;
 Repair, 4-12;
 Replace, 4-12
 (EF #3),
 Repair 3-20
 (EF #4 and 6),
 Repair 3-20
 (SF #1 and 2)

 Assembly, 4-12;
 Disassembly, 4-12;
 Removal, 4-12;
 Repair, 4-12;
 Replace, 4-12
 (SF #3),
 Removal, 3-18;
 Repair, 3-18;
 Replace, 3-18
 (SF #4),
 Removal, 2-26;
 Repair 2-26;
 Replace 2-26; 3-20
 (SF #5),
 Repair 3-20
 (SF #6)
 Removal 2-29, 3-20
 Removal, 2-29
 Replace, 2-29

N

Normal Startup, 2-7, 3-6, 4-6

P

Preparation for Storage or Shipment,
 1-5, 2-37
 Preliminary Servicing and Adjustment,
 2-9

P-CONT

Preventive Maintenance Checks and
 Services (PMCS), 2-10, 3-8, 4-8
 Purging, 3-10, 4-10R

R

Recharging
 (A/C-1 and 3), 3-10
 (A/C-2), 4-10
 Recirculation (Return Air) System, 1-14
 Refrigerant, Adding, 3-10, 4-10
 Refrigerant, Purging, 3-10, 4-10
 Removing Charge
 (A/C-1 and 3), 3-10
 (A/C-2), 4-10
 Repair Parts, 2-3, 3-3, 4-3
 Reporting Equipment Improvement
 Recommendations (EIR), 1-4

S

Safety Care and Handling, 1-10
 Scope, 1-1
 Shutdown Procedure (Usual or Unusual),
 2-8, 3-7, 4-7
 Special Tools, TMDE, and Support
 Equipment, 2-2, 3-2, 4-2
 Supply Air System, 1-12
 Supply System General, 1-11
 Symptom Index, 2-11, 3-9, 4-9

T

Troubleshooting, 2-12, 3-9, 4-9
 Troubleshooting Electrical Voltages and
 Components, 2-14
 Troubleshooting Tips on HVAC Equipment,
 2-13

W

Wiring Diagrams, 2-15

Index 3/(Index 4 blank)

By Order of the Secretary of the Army:

CARL E. VUONO
General United States Army
Chief of Staff

Official:

WILLIAM J. MEEHAN, II
Brigadier General United States Army
The Adjutant General

DISTRIBUTION:

To be distributed in accordance with DA Form 12-25A, Unit, Direct Support and General Support Maintenance requirements for Landing Craft, Utility, LUC-1466, Type III.

☆ U.S. GOVERNMENT PRINTING OFFICE : 1994 0-300-421 (82648)

RECOMMENDED CHANGES TO PUBLICATIONS AND BLANK FORMS For use of this form, see AR 310-1; the proponent agency is the US Army Adjutant General Center.					Use Part II (<i>reverse</i>) for Repair Parts and Special Tool Lists (RPSTL) and Supply Catalogs/Supply Manuals (SC/SM).	DATE: Date form is filled out.
TO: (<i>Forward to proponent of publication or form</i>) (<i>Include ZIP Code</i>) Mailing address found on title block page.					FROM: (<i>Activity and location</i>) (<i>Include ZIP Code</i>) Your mailing address.	
PART I - ALL PUBLICATIONS (EXCEPT RPSTL AND SC/SM) AND BLANK FORMS						
PUBLICATION/FORM NUMBER: TM X-XXXX-XXX-XXX					DATE: Date of the TM.	TITLE: Title of TM.
ITEM NO.	PAGE NO.	PARA-GRAPH	LINE NO.	FIGURE NO.	TABLE NO.	RECOMMENDED CHANGES AND REASON (Exact wording of recommended change must be given)
	0019 00 1	3	1	1		Step No. 2 says to secure doors open with locking bar or hooks from where to what? The bars or hooks are not identified.
	0019 00 4	4	1	1		Step No. 19 states to remove locking bars, pins or hooks from where to what? The bars, pins or hooks are not identified. Where are they stored?
SAMPLE						
* Reference to line numbers within the paragraph or subparagraph.						
TYPED NAME, GRADE OR TITLE Doe, John, CPL			TELEPHONE EXCHANGE/AUTOVON, PLUS EXTENSION 755-1313		SIGNATURE <i>CPL John Doe</i>	

TO: (Forward to proponent of publication or form) (Include ZIP Code)	FROM: (Activity and location) (Include ZIP Code)	DATE:
---	---	--------------

PART II- REPAIR PARTS AND SPECIAL TOOL LISTS AND SUPPLY CATALOGS/SUPPLY MANUALS

PUBLICATION/FORM NUMBER: TM X-XXXX-XXX-XXX	DATE: Date of the TM.	TITLE: Title of TM.
--	---------------------------------	-------------------------------

PAGE NO.	COLM NO.	LINE NO.	FEDERAL STOCK NUMBER	REFERENCE NO.	FIGURE NO.	ITEM NO.	TOTAL NO. OF MAJOR ITEMS SUPPORTED	RECOMMENDED ACTION
----------	----------	----------	----------------------	---------------	------------	----------	------------------------------------	--------------------

--	--	--	--	--	--	--	--	--

SAMPLE

PART III - REMARKS (Any general remarks or recommendations, or suggestions for improvement of publications and blank forms. Additional blank sheets may be used if more space is needed.)

--

* Reference to line numbers within the paragraph or subparagraph.

TYPED NAME, GRADE OR TITLE Doe, John, CPL	TELEPHONE EXCHANGE/AUTOVON, PLUS EXTENSION 755-1313	SIGNATURE CPL John Doe
---	---	----------------------------------

TO: <i>(Forward direct to addressee listed in publication)</i> U.S. Army TACOM Life Cycle Management Command ATTN: AMSTA-LC-LMPP / TECH PUBS 1 Rock Island Arsenal Rock Island, IL 61299-7630	FROM: <i>(Activity and location) (Include ZIP Code)</i>	DATE
--	--	-------------

PART II - REPAIR PARTS AND SPECIAL TOOL LISTS AND SUPPLY CATALOGS/SUPPLY MANUALS

PUBLICATION NUMBER TM 55-1905-223-24-17	DATE 17 January 1989	TITLE Unit, Intermediate Direct Support, and Intermediate General Support Maintenance Instructions Environmental Control Subsystem for Landing Craft, Utility (LCU) NSN 1905-01-154-1191
---	--------------------------------	---

PAGE NO.	COLM NO.	LINE NO.	NATIONAL STOCK NUMBER	REFERENCE NO.	FIGURE NO.	ITEM NO.	TOTAL NO. OF MAJOR ITEMS SUPPORTED	RECOMMENDED ACTION

PART III - REMARKS *(Any general remarks or recommendations, or suggestions for improvement of publications and blank forms. Additional blank sheets may be used if more space is needed.)*

--

TYPED NAME, GRADE OR TITLE	TELEPHONE EXCHANGE/AUTOVON, PLUS EXTENSION	SIGNATURE

RECOMMENDED CHANGES TO PUBLICATIONS AND BLANK FORMS For use of this form, see AR 25-30; the proponent agency is OAASA	Use Part II (reverse) for Repair Parts and Special Tool Lists (RPSTL) and Supply Catalogs/Supply Manuals (SC/SM).	DATE
---	---	------

TO: (Forward to proponent of publication or form) (Include ZIP Code) U.S. Army TACOM Life Cycle Management Command ATTN: AMSTA-LC-LMPP / TECH PUBS 1 Rock Island Arsenal Rock Island, IL 61299-7630	FROM: (Activity and location) (Include ZIP Code)
--	---

PART I - ALL PUBLICATIONS (EXCEPT RPSTL AND SC/SM) AND BLANK FORMS

PUBLICATION/FORM NUMBER TM 55-1905-223-24-17	DATE 17 January 1989	TITLE Unit, Intermediate Direct Support, and Intermediate General Support Maintenance Instructions Environmental Control Subsystem for Landing Craft, Utility (LCU) NSN 1905-01-154-1191
---	-------------------------	---

ITEM	PAGE	PARA-GRAPH	LINE	FIGURE NO.	TABLE	RECOMMENDED CHANGES AND REASON

** Reference to line numbers within the paragraph or subparagraph.*

TYPED NAME, GRADE OR TITLE	TELEPHONE EXCHANGE/AUTOVON, PLUS EXTENSION	SIGNATURE
----------------------------	---	-----------

TO: <i>(Forward direct to addressee listed in publication)</i> U.S. Army TACOM Life Cycle Management Command ATTN: AMSTA-LC-LMPP / TECH PUBS 1 Rock Island Arsenal Rock Island, IL 61299-7630	FROM: <i>(Activity and location) (Include ZIP Code)</i>	DATE
--	--	-------------

PART II - REPAIR PARTS AND SPECIAL TOOL LISTS AND SUPPLY CATALOGS/SUPPLY MANUALS

PUBLICATION NUMBER TM 55-1905-223-24-17	DATE 17 January 1989	TITLE Unit, Intermediate Direct Support, and Intermediate General Support Maintenance Instructions Environmental Control Subsystem for Landing Craft, Utility (LCU) NSN 1905-01-154-1191
---	--------------------------------	---

PAGE NO.	COLM NO.	LINE NO.	NATIONAL STOCK NUMBER	REFERENCE NO.	FIGURE NO.	ITEM NO.	TOTAL NO. OF MAJOR ITEMS SUPPORTED	RECOMMENDED ACTION

PART III - REMARKS *(Any general remarks or recommendations, or suggestions for improvement of publications and blank forms. Additional blank sheets may be used if more space is needed.)*

TYPED NAME, GRADE OR TITLE	TELEPHONE EXCHANGE/AUTOVON, PLUS EXTENSION	SIGNATURE
-----------------------------------	---	------------------

RECOMMENDED CHANGES TO PUBLICATIONS AND BLANK FORMS For use of this form, see AR 25-30; the proponent agency is OAASA	Use Part II (reverse) for Repair Parts and Special Tool Lists (RPSTL) and Supply Catalogs/Supply Manuals (SC/SM).	DATE
---	---	------

TO: (Forward to proponent of publication or form) (Include ZIP Code) U.S. Army TACOM Life Cycle Management Command ATTN: AMSTA-LC-LMPP / TECH PUBS 1 Rock Island Arsenal Rock Island, IL 61299-7630	FROM: (Activity and location) (Include ZIP Code)
--	---

PART I - ALL PUBLICATIONS (EXCEPT RPSTL AND SC/SM) AND BLANK FORMS

PUBLICATION/FORM NUMBER TM 55-1905-223-24-17	DATE 17 January 1989	TITLE Unit, Intermediate Direct Support, and Intermediate General Support Maintenance Instructions Environmental Control Subsystem for Landing Craft, Utility (LCU) NSN 1905-01-154-1191
---	-------------------------	---

ITEM	PAGE	PARA- GRAPH	LINE	FIGURE NO.	TABLE	RECOMMENDED CHANGES AND REASON

** Reference to line numbers within the paragraph or subparagraph.*

TYPED NAME, GRADE OR TITLE	TELEPHONE EXCHANGE/AUTOVON, PLUS EXTENSION	SIGNATURE
----------------------------	---	-----------

TO: (Forward direct to addressee listed in publication) U.S. Army TACOM Life Cycle Management Command ATTN: AMSTA-LC-LMPP / TECH PUBS 1 Rock Island Arsenal Rock Island, IL 61299-7630	FROM: (Activity and location) (Include ZIP Code)	DATE
---	---	-------------

PART II - REPAIR PARTS AND SPECIAL TOOL LISTS AND SUPPLY CATALOGS/SUPPLY MANUALS

PUBLICATION NUMBER TM 55-1905-223-24-17	DATE 17 January 1989	TITLE Unit, Intermediate Direct Support, and Intermediate General Support Maintenance Instructions Environmental Control Subsystem for Landing Craft, Utility (LCU) NSN 1905-01-154-1191
---	--------------------------------	---

PAGE NO.	COLM NO.	LINE NO.	NATIONAL STOCK NUMBER	REFERENCE NO.	FIGURE NO.	ITEM NO.	TOTAL NO. OF MAJOR ITEMS SUPPORTED	RECOMMENDED ACTION

PART III - REMARKS (Any general remarks or recommendations, or suggestions for improvement of publications and blank forms. Additional blank sheets may be used if more space is needed.)

--

TYPED NAME, GRADE OR TITLE	TELEPHONE EXCHANGE/AUTOVON, PLUS EXTENSION	SIGNATURE

The Metric System and Equivalents

Linear Measure

1 centimeter = 10 millimeters = .39 inch
 1 decimeter = 10 centimeters = 3.94 inches
 1 meter = 10 decimeters = 39.37 inches
 1 dekameter = 10 meters = 32.8 feet
 1 hectometer = 10 dekameters = 328.08 feet
 1 kilometer = 10 hectometers = 3,280.8 feet

Weights

1 centigram = 10 milligrams = .15 grain
 1 decigram = 10 centigrams = 1.54 grains
 1 gram = 10 decigrams = .035 ounce
 1 dekagram = 10 grams = .35 ounce
 1 hectogram = 10 dekagrams = 3.52 ounces
 1 kilogram = 10 hectograms = 2.2 pounds
 1 quintal = 100 kilograms = 220.46 pounds
 1 metric ton = 10 quintals = 1.1 short tons

Liquid Measure

1 centiliter = 10 milliliters = .34 fl. ounce
 1 deciliter = 10 centiliters = 3.38 fl. ounces
 1 liter = 10 deciliters = 33.81 fl. ounces
 1 dekaliter = 10 liters = 2.64 gallons
 1 hectoliter = 10 dekaliters = 26.42 gallons
 1 kiloliter = 10 hectoliters = 264.18 gallons

Square Measure

1 sq. centimeter = 100 sq. millimeters = .155 sq. inch
 1 sq. decimeter = 100 sq. centimeters = 15.5 sq. inches
 1 sq. meter (centare) = 100 sq. decimeters = 10.76 sq. feet
 1 sq. dekameter (are) = 100 sq. meters = 1,076.4 sq. feet
 1 sq. hectometer (hectare) = 100 sq. dekameters = 2.47 acres
 1 sq. kilometer = 100 sq. hectometers = .386 sq. mile

Cubic Measure

1 cu. centimeter = 1000 cu. millimeters = .06 cu. inch
 1 cu. decimeter = 1000 cu. centimeters = 61.02 cu. inches
 1 cu. meter = 1000 cu. decimeters = 35.31 cu. feet

Approximate Conversion Factors

To change	To	Multiply by	To change	To	Multiply by
inches	centimeters	2.540	ounce-inches	newton-meters	.007062
feet	meters	.305	centimeters	inches	.394
yards	meters	.914	meters	feet	3.280
miles	kilometers	1.609	meters	yards	1.094
square inches	square centimeters	6.451	kilometers	miles	.621
square feet	square meters	.093	square centimeters	square inches	.155
square yards	square meters	.836	square meters	square feet	10.764
square miles	square kilometers	2.590	square meters	square yards	1.196
acres	square hectometers	.405	square kilometers	square miles	.386
cubic feet	cubic meters	.028	square hectometers	acres	2.471
cubic yards	cubic meters	.765	cubic meters	cubic feet	35.315
fluid ounces	milliliters	29.573	cubic meters	cubic yards	1.308
pints	liters	.473	milliliters	fluid ounces	.034
quarts	liters	.946	liters	pints	2.113
gallons	liters	3.785	liters	quarts	1.057
ounces	grams	28.349	liters	gallons	.264
pounds	kilograms	.454	grams	ounces	.035
short tons	metric tons	.907	kilograms	pounds	2.205
pound-feet	newton-meters	1.356	metric tons	short tons	1.102
pound-inches	newton-meters	.11296			

Temperature (Exact)

°F	Fahrenheit	5/9 (after	Celsius	°C
	temperature	subtracting 32)	temperature	

